

EN Operating and installation instructions ULB3

BORA Air purification box with 3 activated charcoal filters

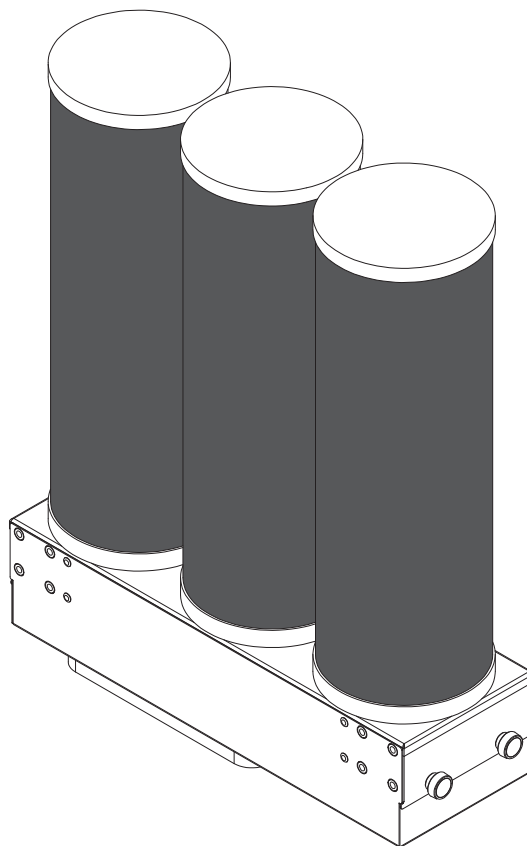

ULB3UMEN-001

Operating and installation instructions:

Original

Translation

Manufacturer

BORA Vertriebs GmbH & Co KG
Prof.-Dr.-Anton-Kathrein-Straße 3
6342 Niederndorf
Austria

Contact
T +43 (0) 5373 / 62250-0
mail@bora.com
www.bora.com

The distribution and duplication of this document, as well as the use and disclosure of its contents are prohibited unless expressly authorised.

These operating and installation instructions have been drawn up with the greatest of care. But it cannot be ruled out that subsequent technical modifications have not yet been incorporated or the relevant content has not yet been adapted. Please accept our apologies in this eventuality. An updated version can be requested from the BORA Service Team. Subject to printing errors and mistakes.

© BORA Vertriebs GmbH & Co KG

All rights reserved.

Table of Contents

| | | |
|----------|--|-----------|
| 1 | General information | 4 |
| 2 | Safety | 6 |
| 2.1 | General safety instructions | 6 |
| 2.2 | Safety instructions – operation | 6 |
| 2.3 | Intended use | 7 |
| 3 | Device description | 8 |
| 3.1 | Technical data | 8 |
| 3.2 | Structure | 8 |
| 3.3 | Functional principle | 9 |
| 4 | Installation | 10 |
| 4.1 | Checking the scope of delivery | 10 |
| 4.2 | Tool and aids | 10 |
| 4.3 | Assembly instructions | 10 |
| 4.4 | Installing the device | 10 |
| 4.4.1 | Installation | 10 |
| 4.4.2 | Connect the duct system to the device. | 11 |
| 4.4.3 | Replacing the filter | 11 |
| 4.5 | Handover to user | 11 |
| 5 | Cleaning and maintenance | 12 |
| 5.1 | Cleaning agents | 12 |
| 5.2 | Cleaning | 12 |
| 6 | Troubleshooting | 13 |
| 7 | Warranty, technical service and spare parts | 14 |
| 7.1 | Warranty | 14 |
| 7.2 | Service | 14 |
| 7.3 | Replacement parts | 14 |

1 General information

Target group

These operating and installation instructions apply for the following target groups:

| Target group | Requirements |
|--------------------------|--|
| User | The appliance can be used by children aged 8 and above as well as people with reduced physical, sensory or mental capacities or a lack of experience and/or knowledge if they are supervised or have been instructed how to safely use the appliance and understand the resultant risks. Children must be supervised. All safety and warning information and the handling instructions in the installation instructions must be complied with. |
| Ambitious DIYers | Ambitious DIYers can independently conduct all joinery and installation work providing they possess the necessary skills and expertise. They must never independently establish electricity and gas connections. |
| Installation specialists | Installation specialists are authorised to conduct all joinery and installation work in line with existing regulations. The electricity and gas connections must be certified by a certified engineer for the applicable trade prior to commissioning. |
| Electricians | The electrical connection may only be established by a certified engineer. He/she also assumes responsibility for the proper electrical installation and commissioning. |
| Gas specialists | The gas connection may only be established by certified engineers. They also assume responsibility for proper installation and commissioning of the gas system. |

Tab. 1.1 Target groups

INFO BORA Holding GmbH, BORA Vertriebs GmbH & Co KG, BORA APAC Pty Ltd and BORA Lüftungstechnik GmbH - hereinafter referred to as BORA - do not assume any liability for damage arising from non-adherence to these documents and from improper assembly! The electricity and gas connections must be made by a qualified specialist. Installation must comply with the valid standards, regulations and laws. All safety and warning information and the operating and installation instructions must be complied with.

Validity of the operating and installation instructions

These instructions apply to several device versions. It is therefore possible that some of the features described do not apply to your appliance.

Other applicable documents

These operating and installation instructions are valid in conjunction with other documents, which must be adhered to.

Please be sure to adhere to all documents that form part of the scope of delivery.

INFO BORA accepts no liability for damage caused by failure to comply with these documents!

Directives

These devices meet the following EU/EC directives:
 2009/125/EC Ecodesign Directive
 2011/65/EU RoHS Directive
 2012/19/EU WEEE Directive

Presentation of information

To make working with these instructions quick and easy, consistent formatting, numbering, symbols,

safety instructions, terms and abbreviations are used throughout.

Handling instructions are marked with an arrow.

- ▶ Always carry out handling instructions in the sequence shown.

Bullet points are indicated by a square bullet point at the edge of the line.

- Bullet point 1
- Bullet point 2

INFO Information points out specific points you must always comply with.

Safety and warning information

The safety and warning information in these instructions are highlighted with symbols and signal words.

Safety and warning information is structured as follows:



WARNING SYMBOL AND SIGNAL WORD!

Type and source of the danger
Consequences of non-compliance

- ▶ Measures to minimise risk
-

The following applies:

- The warning symbol draws attention to the danger.
- The signal word indicates the severity of the risk.

| Warning sign | Signal word | Hazard |
|---|----------------|--|
|  | Danger | Indicates an imminent hazardous situation which could lead to death or serious injury if ignored. |
|  | Warning | Indicates an imminent hazardous situation which could lead to death or serious injury if ignored. |
|  | Caution | Indicates a potentially hazardous situation which could lead to slight or minor injuries if ignored. |
| – | Caution | Indicates a situation which could result in material damage if ignored. |

Tab. 1.2 Meaning of warning symbols and signal words

2 Safety

2.1 General safety instructions

INFO The appliance complies with the stipulated safety requirements. The user is responsible for appliance cleaning and maintenance as well as its safe use. Improper use can lead to personal injury and damage to property.

- The operating and installation instructions contain important information about installation and operation. These enable you to protect yourself against injuries and prevent damage to the appliance. Contact details for further information as well as application and usage questions can be found on the back of these operating and installation instructions.
- The term device is used to describe the BORA air purification box ULB1 and the BORA air purification box with 3 activated charcoal filters (ULB3).
 - ▶ Read the operating and installation instructions fully before using the appliance for the first time.
 - ▶ Always store the operating and installation instructions within easy reach so that they can be accessed if required.
 - ▶ Pass the operating and installation instructions to the next owner if you sell the appliance.
 - ▶ Conduct all work extremely attentively and conscientiously.
 - ▶ Check the appliance for visible damage when unpacking it.
 - ▶ Do not connect a damaged appliance.
 - ▶ Only use the appliance once all installation activities are complete. This is the only way to ensure safe operation.
 - ▶ Keep pets away from the appliance.

Recirculation mode

INFO When cooking, additional moisture is released into the ambient air.

INFO In recirculation mode, only a slight amount of moisture is removed from the cooking vapour.

- ▶ When using recirculation mode, ensure a sufficient supply of fresh air, e.g. by opening a window.

- ▶ Ensure a normal and comfortable room climate (humidity of 45–60%), e.g. by opening natural ventilation openings or using domestic ventilation systems.
- ▶ After every use in recirculation mode, switch the cooktop extractor to a low level for about 15 minutes or activate the automatic after-run function.

Households with children and people with special needs

- ▶ The appliance can be used by children aged 8 and above as well as people with reduced physical, sensory or mental capacities or a lack of experience and/or knowledge if they are supervised or have been instructed how to safely use the appliance and understand the resultant risks.
- ▶ Supervise children in the vicinity of the appliance.
- ▶ Children must not play with the appliance.
- ▶ Do not store any items that could be of interest to children in storage spaces above or behind the appliance. Children will otherwise be encouraged to climb on the appliance.

Unauthorised modifications

Unauthorised modifications can cause the appliance to pose risks.

- ▶ Do not conduct any modifications to the appliance.

Cleaning and maintenance

The activated charcoal filters must be regularly replaced.

Dirty filters can lead to unpleasant odours (see the Cleaning and maintenance section).

2.2 Safety instructions – operation

The appliance must only be used in connection with a BORA cooktop extractor.

Please also see the BORA cooktop extractor operating instructions in this regard.

2.3 Intended use

The appliance is only intended for use in private households to reduce odours during food preparation. It is not intended for:

- Outdoor use
- Installation in vehicles
- Heating rooms
- Use in non-stationary installation sites (e.g. on ships)
- Use with an external timer or a separate remote control system (remote operation)

Any use other than that specified in these operating and installation instructions or any use that goes beyond that which is described here is classed as unintended. BORA does not assume any liability for damages caused by improper use or incorrect operation.

All misuse is prohibited!

INFO BORA Holding GmbH, BORA Vertriebs GmbH & Co KG, BORA APAC Pty Ltd and BORA Lüftungstechnik GmbH do not assume any liability for damage arising from non-adherence to the safety and warning information.

3 Device description

- Observe all safety and warning information during operation (see the Safety section).

The BORA air purification box with 3 activated charcoal filters (ULB3) has the following features:

- Activated charcoal filter cartridges
- Fine filter
- Housing plinth

3.1 Technical data

| Parameter | Value |
|--------------------------------------|--|
| Weight (incl. accessories/packaging) | approx. 11.5 kg |
| Activated charcoal granulate volume | 3 x 4 litres = 12 litres (= 8.5 kg) |
| Housing material | Galvanised metal |
| Dimensions | (width x depth x height) |
| Device with plinth | 465 x 150 x 590 mm |
| Inlet opening | (exterior dimensions) 245 x 89 mm |

Tab. 3.1 Technical data

3.2 Structure

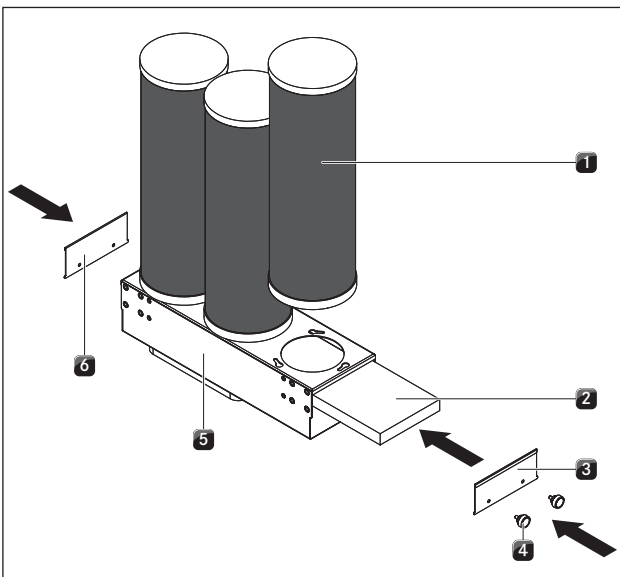

Fig. 3.1 BORA Air purification box with 3 activated charcoal filters (ULB3)

- [1] Activated charcoal filter cartridge
- [2] Fine filter
- [3] Right-hand cover flap
- [4] Knurled screw
- [5] Housing plinth
- [6] Left-hand cover flap

Device dimensions

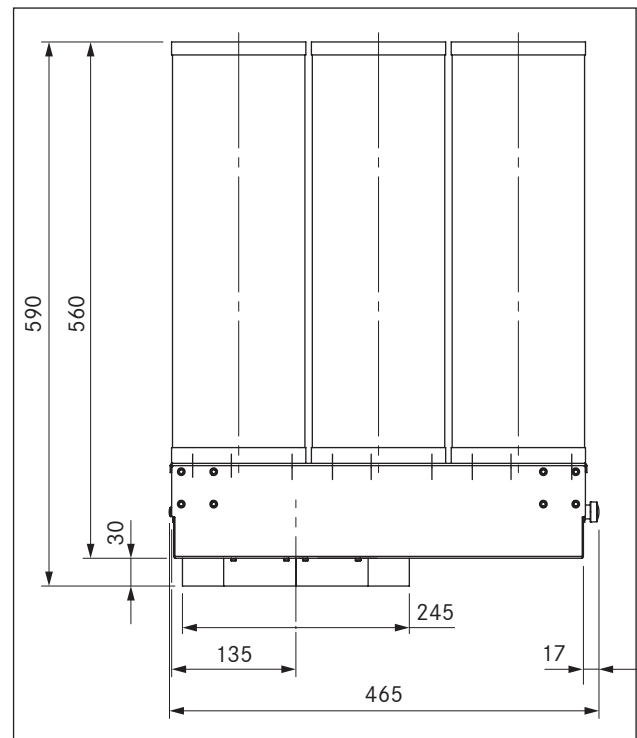

Fig. 3.2 ULB3 Front view

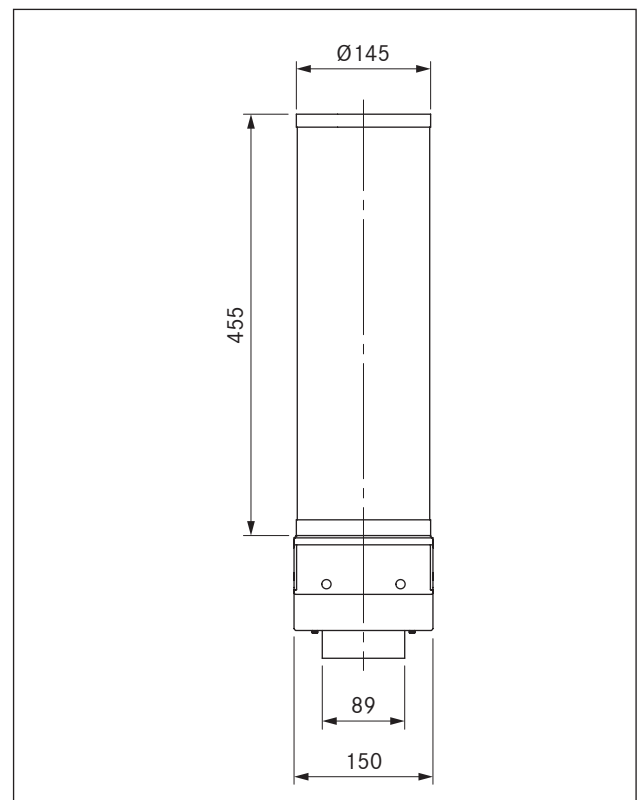

Fig. 3.3 ULB3 Side view

3.3 Functional principle

- The cooking vapours created are extracted at the cooktop by the BORA cooktop extractor and fed into the recirculation unit.
- Inside the housing plinth, the cooking vapour is pre-filtered by the fine filter.
- Activated charcoal granulate in the three activated charcoal filter cartridges absorbs any odours.
- The purified air is then expelled.

4 Installation

- ▶ Observe all safety and warning information (see the Safety section).
- ▶ Follow the enclosed manufacturer's information.

INFO The product must not be installed above cooling devices, dishwashers, stoves, ovens, washing machines or driers.

4.1 Checking the scope of delivery

| Name | Quantity |
|---|----------|
| Activated charcoal filter cartridges | 3 |
| Operating and installation instructions | 1 |
| Fixing screw set | 1 |
| Angle bracket | 2 |
| Mounting bracket | 2 |
| Housing plinth | 1 |
| Fine filter | 1 |

Tab. 4.1 Scope of delivery

- ▶ Check the scope of delivery for damage and make sure it is complete.
- ▶ If there are any missing or damaged parts, please notify BORA After Sales Service.
- ▶ Do not under any circumstances install parts which are damaged.
- ▶ Dispose of transport packaging in the proper manner (see the Decommissioning and Disposal section).

4.2 Tool and aids

The following tool is required to correctly install the recirculation unit:

- Phillips screwdriver

4.3 Assembly instructions

- Keep the airflow channels as short as possible.
- Do not install the device in floor units or bodies with no separation from the doors or drawers. as the positive pressure could cause these to open of their own accord.
- The drawers, back panels and shelves in the floor unit must be removable for maintenance and cleaning purposes.

- If the device is installed in an adjacent room, air recirculation must occur in the room in which the vapour extraction system is installed so as not to generate any low pressure. Use the UUERH0 air recirculation hood available as an accessory for this purpose.

4.4 Installing the device

INFO A return flow aperture of > 500 cm² in the plinth area must be provided for recirculation.

INFO The air duct diameter must be no less than 150 mm (176 cm²).

INFO With an air duct length of 50 cm, no corner or bend should be installed before the fan module (motor).

INFO Install straight duct pieces with a length of at least 50 cm between the corners or bends.

4.4.1 Installation

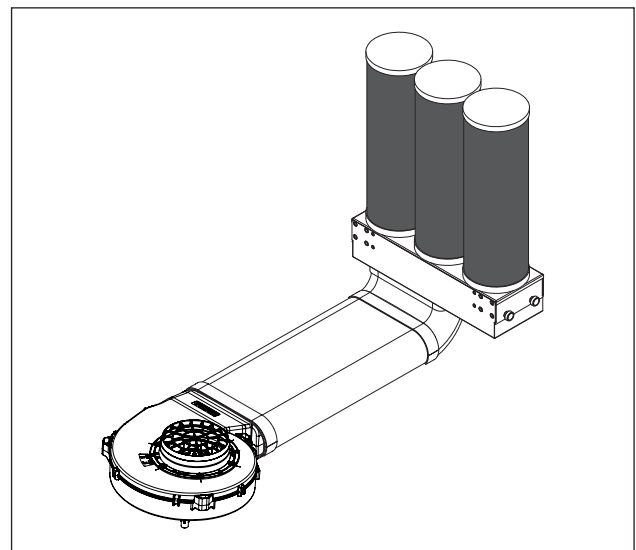

Fig. 4.1 Installed air purification box

- ▶ Depending on the installation situation, screw the knurled screw to the left or right of the opening on the housing plinth to allow unobstructed access to the fine filter.
- ▶ Depending on the attachment method, attach the angle or mounting brackets to the housing plinth.
- ▶ Connect the duct with the housing plinth's ducting.
- ▶ Use the screws provided to attach the housing plinth.
- ▶ Insert each activated charcoal filter cartridge into the intended opening and then twist it clockwise.

4.4.2 Connect the duct system to the device.

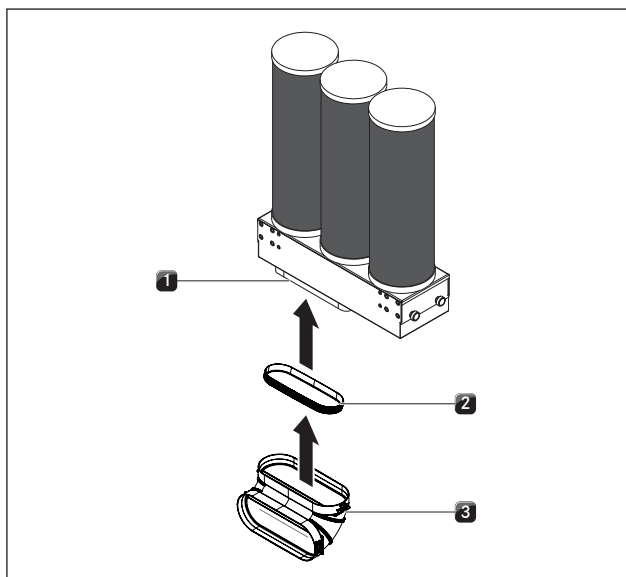

Fig. 4.2 Connecting the BORA Ecotube duct system

- [1] Connection fittings
- [2] Seal
- [3] BORA Ecotube duct piece (Ecotube duct connector or Ecotube moulded part)

- ▶ Pull out the seal [2] on the connection fitting [1] of the device. This means stretching the seal [2] slightly.
- ▶ Push the Ecotube duct piece [3] to be connected with the sleeve on the connection fitting [1] with the seal [2].
- ▶ Make sure the seal [2] does not move.

INFO Make sure that the seal makes a good seal with the connecting duct piece when compressed.

4.4.3 Replacing the filter

Switch off the cooktop extractor as shown in the BORA cooktop extractor operating instructions.

- ▶ Open the revision option to access you appliance.
- Follow the steps below to completely replace the appliance:
 - ▶ Loosen the appliance with the angle brackets.
 - ▶ Remove the appliance from the ducting.
 - ▶ Clean the ducting with a soft cloth and detergent or water.
- Install the replacement appliance as described in the Installation section
- Follow the steps below to replace the filter:
 - ▶ Loosen the activated charcoal filter cartridges by twisting them anticlockwise.
 - ▶ Carefully remove the loosened activated charcoal filter cartridges.
 - ▶ Install the new activated charcoal filter cartridges one after another.

- ▶ Open the cover flap attached to the left or right hand side.
- ▶ Remove the used fine filter.
- ▶ Carefully insert the new fine filter.
- ▶ Close the cover flap.
- ▶ Check that all the duct connections are tight and secure.
- ▶ Check that the appliance functions correctly.
- ▶ Do this by putting the cooktop extractor into operation as shown in the BORA cooktop extractor operating instructions.
- ▶ Seal the revision option.
- ▶ Properly dispose of the used filter.

4.5 Handover to user

Once installation is complete:

- ▶ Explain the main functions to the user.
- ▶ Explain all safety-related aspects of operation and handling to the user.
- ▶ Provide the user with the accessories and the operating and installation instructions for safe storage.

5 Cleaning and maintenance

- ▶ Observe all safety and warning information (see the Safety section).
- ▶ Follow the enclosed manufacturer's information.
- ▶ When conducting scheduled cleaning and other work on the appliance, ensure that the cooktop extractor is fully switched off so as to prevent injury. For how to do this, please see the BORA cooktop extractor operating instructions.
- ▶ After every use, switch the cooktop extractor to a low level for about 15 minutes or activate the automatic after-run function.
- ▶ Stick to the following replacement intervals:
 - In the event of odour formation
 - Declining extraction performance

| Component | Replacement cycle |
|--|-------------------|
| BORA Air purification box with 3 activated charcoal filters (ULB3) | Every 2 years |

Tab. 5.1 Replacement cycle

5.1 Cleaning agents

- ▶ Never use steam cleaners, abrasive sponges, scouring pads or chemically aggressive cleaning agents (e.g. oven cleaner spray).
- ▶ Make sure that the cleaning agent does not contain any sand, soda, acids, lyes or chloride.

5.2 Cleaning

Users are not intended to clean the inside of the appliance and must not do this under any circumstances.

6 Troubleshooting

► Observe all safety and warning information (see the Safety section).

| Operating situation | Cause | Remedy |
|---------------------|---|--|
| Unpleasant odours. | The automatic after-run is not used. | Use the automatic after-run. |
| | Recirculation unit usage period exceeded. | Replace the air purification box/activated charcoal filter and pre-filter on the ULB3. |

Tab. 6.1 Resolving a fault

► In all other instances, contact BORA After Sales Service (see the Warranty, technical service and spare parts section).

7 Warranty, technical service and spare parts

- ▶ Observe all safety and warning information (see the Safety section).

7.1 Warranty

The warranty period is 2 years.

7.2 Service

BORA Service:

see back page of operation and installation instructions



- ▶ If there are faults which you are not able to resolve yourself, please contact your BORA specialist supplier or the BORA Service Team.

The BORA Service Team requires the type designation and the build number of your appliance (FD number). Both pieces of information can be found on the nameplate on the back of the instructions and on the appliance base.

7.3 Replacement parts

- ▶ Only use original spare parts for repairs.

INFO Replacement parts can be obtained from your BORA dealer, the BORA online service website at www.bora.com/service or by calling the service number provided.

Nameplate:
(please affix)

Germany:

BORA Lüftungstechnik GmbH
Rosenheimer Str. 33
83064 Raubling
Germany
T +49 (0) 8035 / 907-240
F +49 (0) 8035 / 907-249
info@bora.com
www.bora.com

Australia - New Zealand:

BORA APAC Pty Ltd
100 Victoria Road
Drummoyne NSW 2047
Australia
T +61 2 9719 2350
F +61 2 8076 3514
info@boraapac.com.au
www.bora-australia.com.au

Austria:

BORA Vertriebs GmbH & Co KG
Prof.-Dr.-Anton-Kathrein-Straße 3
6342 Niederndorf
Austria
T +43 (0) 5373 / 62250-0
F +43 (0) 5373 / 62250-90
mail@bora.com
www.bora.com

Europe:

BORA Holding GmbH
Prof.-Dr.-Anton-Kathrein-Straße 3
6342 Niederndorf
Austria
T +43 (0) 5373 / 62250-0
F +43 (0) 5373 / 62250-90
mail@bora.com
www.bora.com

