

EN Installation instructions – ULIE

BORA additional duct fan – AC

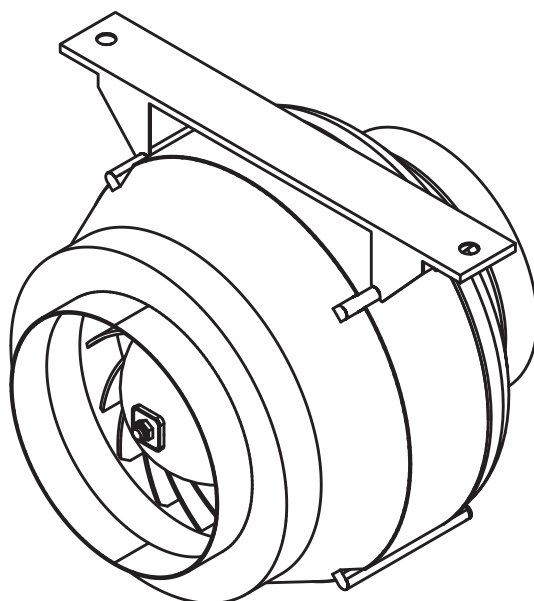

ULIEUMEN-000

Operating and installation instructions:

Original

Translation

Manufacturer

BORA Vertriebs GmbH & Co KG
Prof.-Dr.-Anton-Kathrein-Straße 3
6342 Niederndorf
Austria

Contact
T +43 (0) 5373 / 62250-0
mail@bora.com
www.bora.com

The distribution and duplication of this document, as well as the use and disclosure of its contents are prohibited unless expressly authorised.

These operating and installation instructions have been drawn up with the greatest of care. But it cannot be ruled out that subsequent technical modifications have not yet been incorporated or the relevant content has not yet been adapted. Please accept our apologies in this eventuality. An updated version can be requested from the BORA Service Team. Subject to printing errors and mistakes.

© BORA Vertriebs GmbH & Co KG

All rights reserved.

1 General information, safety information

1.1 Other applicable documents

There are other documents that apply and must be observed along with these operating and installation instructions.

Observe all the documents relating to the BORA cooktop extractor, which are a component of the particular scope of delivery.

Directives

The device complies with the following EU directives:

2014/35/EU Low Voltage Directive
 2014/30/EU EMC Directive
 (EU) 640/2009 Electric Motors Ordinance
 2011/65/EU RoHS Directive
 2012/19/EU WEEE Directive

1.2 Use as intended

The device is intended for the removal of cooking vapours in combination with a BORA cooktop extractor in private households only. This device is not intended for:

- fitting in vehicles
- installation outdoors
- airing a room

BORA is not liable for damage caused by improper use or wrong operation.

All misuse is prohibited!

1.3 Safety instructions for installation and disassembly

Installation: the appliance may be installed and disassembled by qualified specialists only, who know and observe the customary regulations and additional regulations of the local utility company.



WARNING!

Danger of injury from a moving fan wheel!

If the fan wheel turns, there is risk of injury.

- ▶ Install the appliance in a tension-free condition exclusively.
- ▶ Before commissioning, connect the fan to both sides of the duct system.
- ▶ Ensure it is protected against movement by a sufficiently long duct cable on both sides.

- ▶ Observe the maximum ambient temperature on the nameplate.

INFO

BORA Holding GmbH, BORA Vertriebs GmbH & Co KG, BORA APAC Pty Ltd and BORA Lüftungstechnik GmbH are not liable for damage arising from non-compliance with the safety and warning information.

2 Technical data

Parameter	Value
Supply voltage	220 - 240 V
Frequency	50 Hz
Power consumption	124 W
Current consumption	0.6 A
Maximum ambient temperature	55°C
Maximum displacement volume	749 m ³ /h
Maximum static pressure	400 Pa
Dimensions (WxDxH)	238 x 260 x 243 mm
Weight (incl. accessories/packaging)	4.5 kg
Housing material	Plastic/galvanised metal
Duct connection size	Ø 150 - 155 mm
Power supply cable	10 m

Tab. 2.1 Technical data

2.1 Device size (mm)

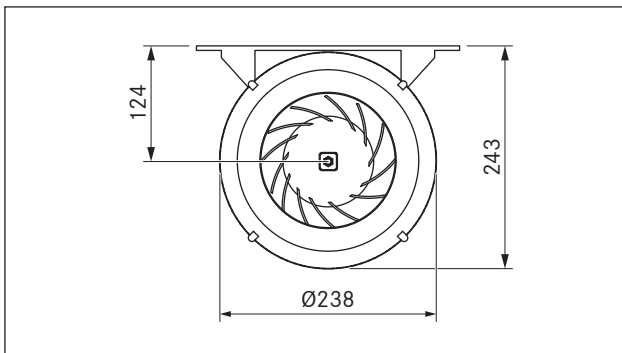

Fig. 2.1 Front view

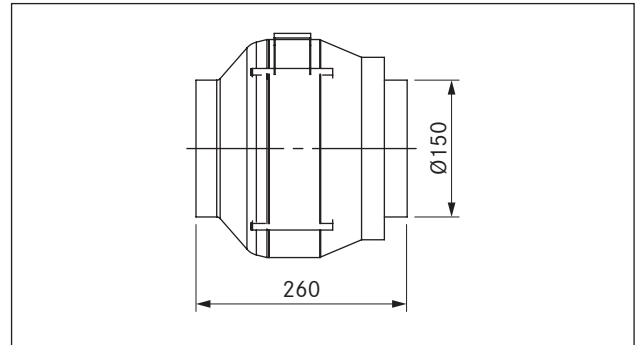

Fig. 2.2 Side view

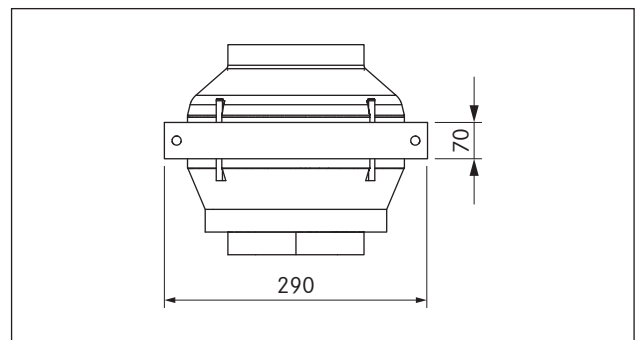

Fig. 2.3 Top view

3 Device description

- Installation in a round duct system with a diameter of 150 mm.
- Can be installed as a additional fan to a BORA fan module.
- Mounting bracket:bore hole for fixing device \varnothing 9 mm.
- Fixing devices must be provided at the installation site.
- If there are two fan modules in one exhaust air duct system, a minimum distance of 3 m must be observed between these two fans.
- The fans can be connected directly to the appliance control box and the home out interface.

3.1 Structure

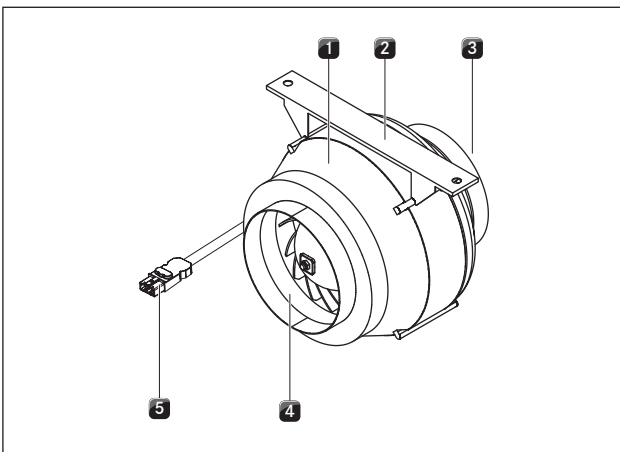

Fig. 3.1 Structure of additional duct fan

- [1] Additional duct fan
- [2] Mounting bracket
- [3] Air outlet
- [4] Air inlet
- [5] Mains cable with connection plug, 10 m

4 Installation information

- ▶ Observe the safety and warning information in these operating and installation instructions, as well those of the BORA cooktop extractor (see section Safety).

4.1 Check scope of delivery

Name	Number
ULIE additional duct fan	1
Assembly information	1
Mounting bracket	1
EPDM sealing tape	1

Tab. 4.1 Scope of delivery

- ▶ Check the scope of delivery for completeness and damage
- ▶ Notify BORA customer services if parts of the delivery are missing or damaged.
- ▶ Do not assemble damaged parts under any circumstances.
- ▶ Remove the transport packaging properly.

4.2 Install additional duct fan

INFO The additional duct fan can be assembled anywhere.

- ▶ Observe all of the measures provided at the installation site to install the fan correctly and without any errors in consultation with all the trades concerned.
- ▶ If necessary, install a steam trap (not contained in the scope of delivery).

4.2.1 Installation

- ▶ Clean the floor of heavy soiling.
- ▶ Remove the mounting bracket [2] from the additional duct fan [1].
- ▶ Install the mounting bracket [2].
- The mounting bracket must be mounted according to the structure of the building.
- ▶ Hang the additional duct fan [1] in the mounting bracket [2] according to the direction of the air stream.
- The direction of the air stream is shown by an arrow on the label of the appliance.
- ▶ Connect the additional duct fan [1] to both sides of the duct system.
- ▶ Ensure the duct system is not taut.
- ▶ Lay the connection cable [5].

4.2.2 Connection to the BORA Ecotube duct system

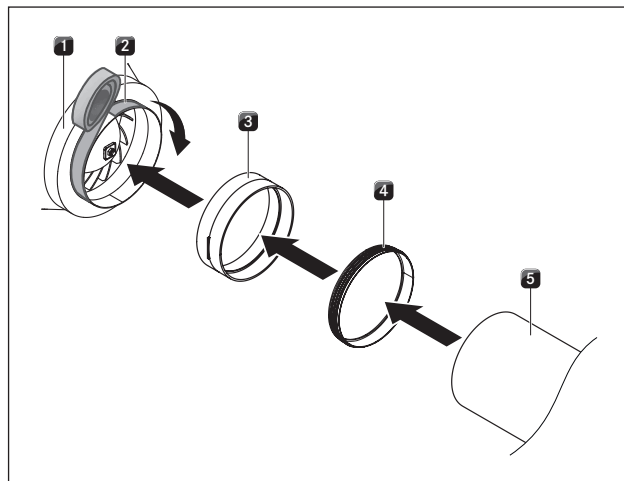

Fig. 4.1 Connection to BORA Ecotube duct system

- [1] ULIE additional duct fan
- [2] EPDM sealing tape
- [3] ERV duct connection (not contained in the scope of delivery)
- [4] ERD seal (not contained in the scope of delivery)
- [5] ER round duct (not contained in the scope of delivery)

- ▶ Join the fan to the Ecotube duct system as shown.

4.2.3 Connection to the control unit

- ▶ Connect the power supply cable of the fan to the control unit of the cooktop extractor.
- ▶ Check that the plug and socket fit snugly.
- ▶ Make sure the cable is not damaged.
- ▶ Check that the installation correct.

5 Decommissioning, disassembly and disposal

- ▶ Observe all of the safety and warning information (see section Safety).

5.1 Decommissioning

Decommissioning means final decommissioning and disassembly. In connection with decommissioning, the appliance can either be reinstalled professionally, sold on privately or disposed of.

INFO Only qualified specialists may disconnect the electrical connection.

- ▶ Turn off the appliance when decommissioning (see section Operation).
- ▶ Cut off the voltage supply from the appliance.

5.2 Disassembly

To remove the appliance, it must be accessible for disassembly and cut off from the voltage supply.

- ▶ Separate the duct system from the fan.
- ▶ Remove the fan from the mounting bracket.
- ▶ Remove other accessories.
- ▶ Dispose of the old appliance and soiled accessories as described under "Eco-friendly disposal".

5.3 Eco-friendly disposal

Disposal of transport packaging

INFO The packaging protects the appliance from damage during transport. The packaging materials are selected with a view to eco-friendly disposal, and are therefore recyclable.

Recycling the packaging in the materials cycle saves on resources and lowers the amount of waste. Your specialist supplier takes the packaging back.

- ▶ Give the packaging to your specialist supplier or
- ▶ Dispose of the packaging correctly in accordance with regional regulations.

Disposal of the old appliance



Electrical appliances marked with this symbol do not belong in the household waste at the end of their useful life. They must be disposed of at a collection point for recycling electrical and electronic devices. If necessary, you can obtain further information about this from the town or municipal authorities.

Electrical and electronic appliances contain a multitude of valuable materials. But they also contain harmful substances that are necessary for their function and safety. These can be harmful to human health and the environment if they are left with residual waste or handled incorrectly.

- ▶ Under no circumstances dispose of your old appliance with household waste.
- ▶ Bring the old appliance to a regional collection point for returning and processing electrical and electronic components, and other materials.

Nameplate:
(please affix)

Germany:

BORA Lüftungstechnik GmbH
Rosenheimer Str. 33
83064 Raubling
Germany
T +49 (0) 8035 / 907-240
F +49 (0) 8035 / 907-249
info@bora.com
www.bora.com

Australia - New Zealand:

BORA APAC Pty Ltd
100 Victoria Road
Drummoyne NSW 2047
Australia
T +61 2 9719 2350
F +61 2 8076 3514
info@boraapac.com.au
www.bora-australia.com.au

Austria:

BORA Vertriebs GmbH & Co KG
Prof.-Dr.-Anton-Kathrein-Straße 3
6342 Niederndorf
Austria
T +43 (0) 5373 / 62250-0
F +43 (0) 5373 / 62250-90
mail@bora.com
www.bora.com

Europe:

BORA Holding GmbH
Prof.-Dr.-Anton-Kathrein-Straße 3
6342 Niederndorf
Austria
T +43 (0) 5373 / 62250-0
F +43 (0) 5373 / 62250-90
mail@bora.com
www.bora.com

