

EN Installation instructions

BORA tiled roof fan – EC

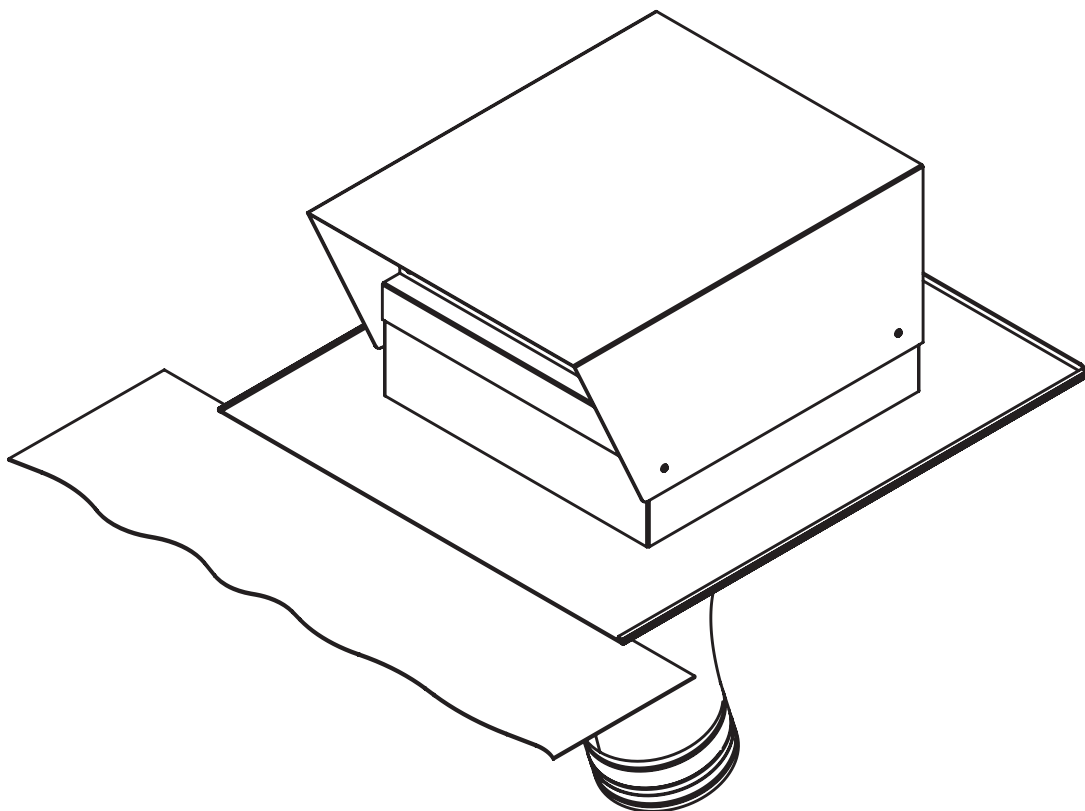

ULZUMEN-100

1 General information, safety information

1.1 Other applicable documents

There are other documents that apply and must be observed along with these operating and installation instructions. Observe all the documents relating to the BORA cooktop extractor, which are a component of the particular scope of delivery.

Directives

The device complies with the following EU directives:

2014/35/EU Low Voltage Directive
 2014/30/EU EMC Directive
 (EU) 640/2009 Electric Motors Ordinance
 2011/65/EU RoHS Directive
 2012/19/EU WEEE Directive

1.2 Use as intended

The device is intended for the removal of cooking vapours in combination with a BORA cooktop extractor in private households only. This device is not intended for:

- fitting in vehicles
- airing a room

BORA is not liable for damage caused by improper use or wrong operation.

All misuse is prohibited!

1.3 Safety instructions for installation and disassembly

Installation: the appliance may be installed and disassembled by qualified specialists only, who know and observe the customary regulations and additional regulations of the local utility company.

⚠ WARNING!

Danger of injury from a moving fan wheel!

If the fan wheel turns, there is risk of injury.

- ▶ Install the appliance in a tension-free condition exclusively.
- ▶ Before commissioning, connect the fan to the duct system.

- ▶ Observe the maximum ambient temperature on the nameplate.

i For more detailed information on decommissioning, disassembly and disposal, please see the instructions provided with the cooktop extractor.

i BORA Holding GmbH, BORA Vertriebs GmbH & Co KG, BORA APAC Pty Ltd and BORA Lüftungstechnik GmbH are not liable for damage arising from non-compliance with the safety and warning information.

Installation instructions: Original Translation

Manufacturer: BORA Vertriebs GmbH & Co KG

The distribution and duplication of this document, as well as the use and disclosure of its contents are prohibited unless expressly authorised.

 +800 7890 0987



These operating and installation instructions have been drawn up with the greatest of care. But it cannot be ruled out that subsequent technical modifications have not yet been incorporated or the relevant content has not yet been adapted. Please accept our apologies in this eventuality. An updated version can be requested from the BORA Service Team. Subject to printing errors and mistakes.

© BORA Vertriebs GmbH & Co KG

All rights reserved.

(D)
BORA Lüftungstechnik GmbH
 Rosenheimer Str. 33
 83064 Raubling
 Germany
 T +49 (0) 8035 / 9840-0
 F +49 (0) 8035 / 9840-300
 info@bora.com
 www.bora.com

(A)
BORA Vertriebs GmbH & Co KG
 Innstraße 1
 6342 Niederndorf
 Austria
 T +43 (0) 5373 / 62250-0
 F +43 (0) 5373 / 62250-90
 mail@bora.com
 www.bora.com

(INT)
BORA Holding GmbH
 Innstraße 1
 6342 Niederndorf
 Austria
 T +43 (0) 5373 / 62250-0
 F +43 (0) 5373 / 62250-90
 mail@bora.com
 www.bora.com

(AU) (NZ)
BORA APAC Pty Ltd
 100 Victoria Road
 Drummoyne NSW 2047
 Australien
 T +61 2 9719 2350
 F +61 2 8076 3514
 info@boraapac.com.au
 www.bora-australia.com.au

5 Technical data / Device description

5.1 Technical data

Parameters	Value
Supply voltage	220 - 240 V
Frequency	50 Hz
Power consumption	206 W
Current consumption	1.66 A
Maximum ambient temperature	70°C
Maximum displacement volume	1210 m ³ /h
Maximum static pressure	650 Pa
Dimensions (WxDxH)	390 x 500 x 280 mm
Weight (incl. accessories/packaging)	16.5 kg
Housing material	Galvanised stainless steel / stainless steel
Duct connection size	Ø 150 - 155 mm
Power supply cable	10 m
Control line	10 m

Fig. 5.1 Technical data

Appliance size (mm)

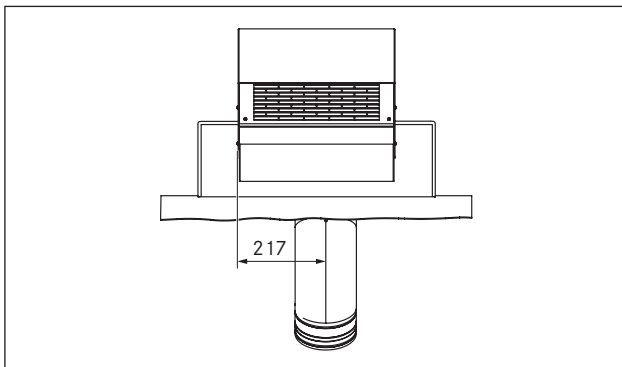

Fig. 5.1 Front view

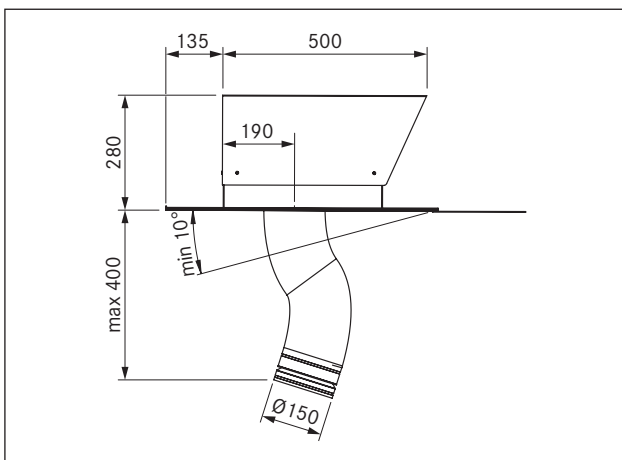

Fig. 5.2 Side view

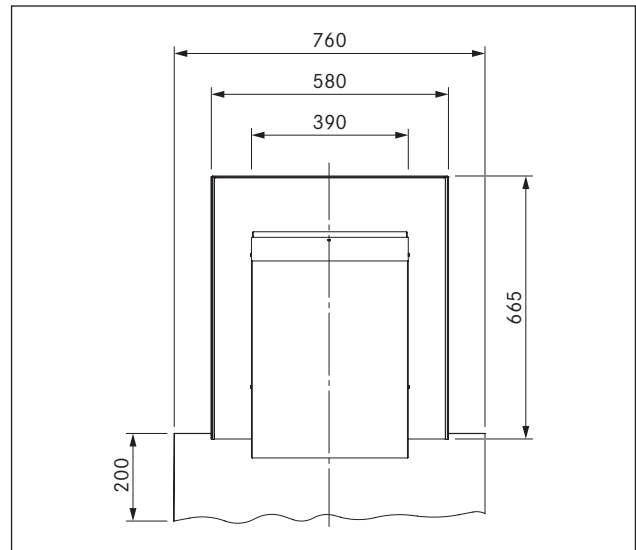

Fig. 5.3 Top view

5.2 Device description

- Installation on a tiled roof with a roof inclination of at least 10°.
- Downward air outlet.
- Fixing devices must be provided at the installation site.
- For an exhaust channel of more than 6 m in length or high pressure drops, the tiled roof fan must be supplemented by a universal fan module.
- If there are two fan modules in one exhaust air duct system, a minimum distance of 3 m must be observed between these two fans

Structure

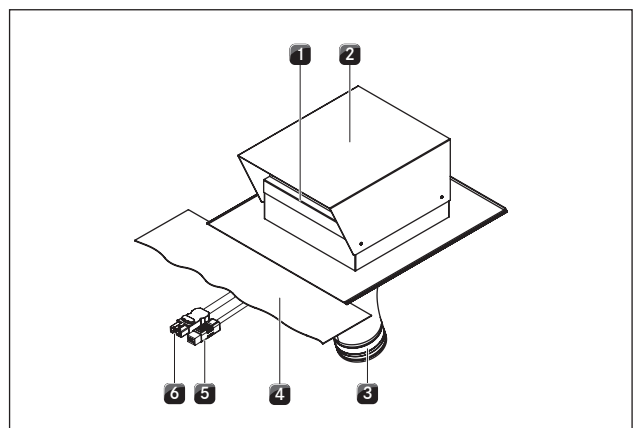

Fig. 5.1 Structure of tiled roof fan

- [1] Air outlet
- [2] Tiled roof fan
- [3] Fabric tube with integrated backflow trap
- [4] Flexible lead aprons
- [5] Control line with connection plug, 10 m
- [6] Mains cable with connection plug, 10 m

5 Installation information

- ▶ Observe the safety and warning information in these operating and installation instructions, as well those of the BORA cooktop extractor (see section Safety).

5.1 Check scope of delivery

Name	Number
ULZ tiled roof fan	1
Installation information	1
Fabric tube with integrated backflow trap	1
EPDM sealing tape	1
Split ferrite sleeve	4

Tab. 5.1 Scope of delivery

- ▶ Check the scope of delivery for completeness and damage
- ▶ Notify BORA customer services if parts of the delivery are missing or damaged.
- ▶ Do not install damaged parts under any circumstances.
- ▶ Remove the transport packaging properly.

5.2 Install tiled roof fan

i The tiled roof fan must be installed in a downwards direction with the air outlet opening.

- ▶ Observe all of the measures provided at the installation site to install the fan correctly and without any errors in consultation with all the trades concerned.
- ▶ Plan for a separate empty duct to lead the control line and mains connection through the roof (not contained in the scope of delivery).
- ▶ Make sure the roof is properly sealed.
- ▶ If necessary, install a steam trap (not contained in the scope of delivery).

5.2.1 Installation

- ▶ Clean the floor of heavy soiling.
- ▶ Lay both connection cables [5], [6] through the roof.
- ▶ Mount the tiled roof fan [2] on the roof.
- The tiled roof fan must be mounted according to the structure of the building.
- The tiled roof fan must be integrated properly into the roof seal.
- ▶ Mould the flexible lead aprons [4] over the roof tiles.
- ▶ Connect the fabric tube [3] to the duct system.
- ▶ Ensure the duct system is not taut.
- ▶ Lay both connection cables [5], [6].

5.2.2 Connection to the BORA Ecotube duct system

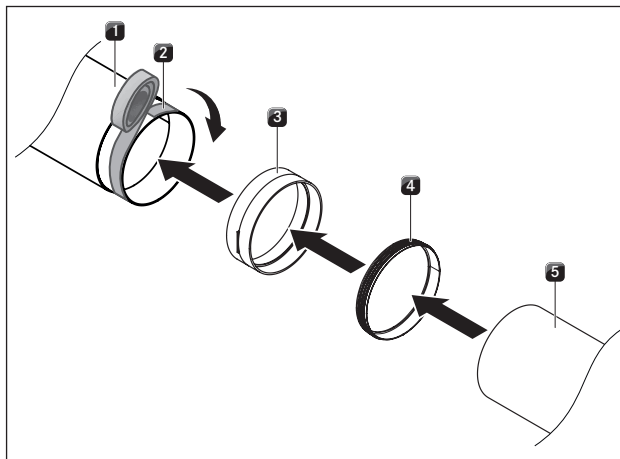

Fig. 5.1 Connection to BORA Ecotube duct system

- [1] Fabric tube with backflow trap
- [2] EPDM sealing tape
- [3] ERV duct connection (not contained in the scope of delivery)
- [4] ERD seal (not contained in the scope of delivery)
- [5] ER750 round duct (not contained in the scope of delivery)

- ▶ Join the fan to the Ecotube duct system as shown.

5.2.3 Connection to the control unit

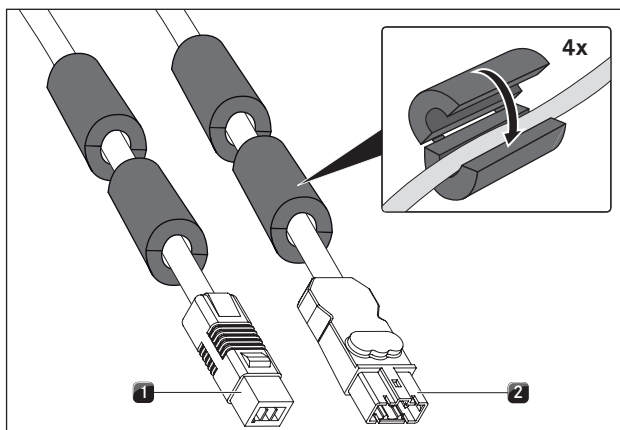

Fig. 5.2 Connection plug for the tiled roof fan

- [1] Connection plug for the control line
- [2] Connection plug for the power supply cable

- ▶ Attach the split ferrites provided with the product to the fan's connection cables (2 to each).
- ▶ Connect the control line [1] of the fan to the control unit of the cooktop extractor.
- ▶ Connect the power supply cable [2] of the fan to the control unit of the cooktop extractor.
- ▶ Check that the plugs and sockets fit snugly.
- ▶ Make sure the cable is not damaged.
- ▶ Check that the installation correct.