

# PKCH3 / PKCH3AB

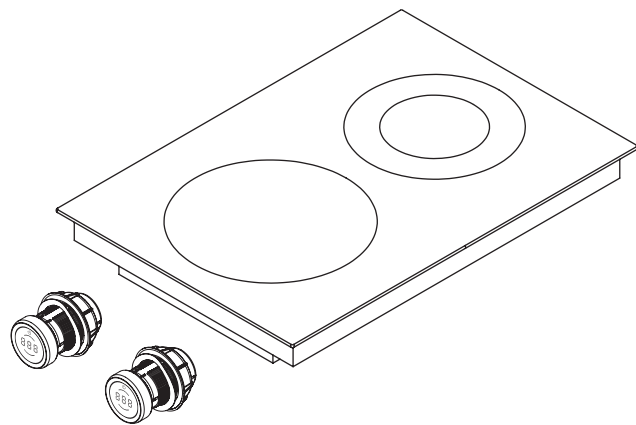

Pro Hyper cooktop 1-ring/2-ring

Pro Hyper cooktop 1-ring/2-ring All Black

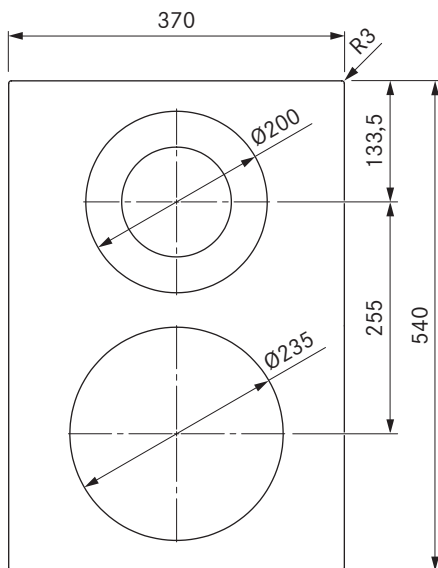
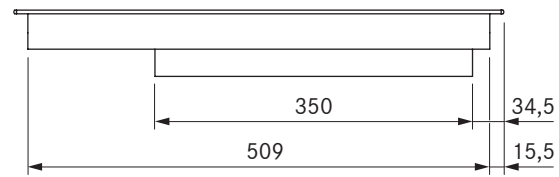
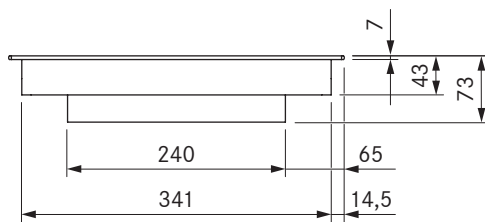

## Technical data

Supply voltage	380 - 415 V 2N
Frequency	50/60 Hz
Maximum power consumption	5.1 kW
Maximum power rating	5.1 kW
Minimum fuse protection	2 x 16 A
Power supply cable length	1,5 m
Dimensions (width x depth x height)	370 x 540 x 73 mm
Weight (incl. accessories/packaging)	8.7 kg
Surface material	SCHOTT CERAN®
Cooktop power levels	1 - 9 (switching of 2-ring/hyper)
Number of cooking zone circuits front	1
Number of cooking zone circuits rear	2
Size of front cooking zone	Ø 235 mm
Size of rear cooking zone	Ø 120 / 200 mm
Front cooking zone output	2100 W
Rear cooking zone output	800 / 1900 W
Front cooking zone power setting output	3200 W

## Product description

- Intuitive control knob
- Variable heat retention function
- Super fast parboiling
- 2-ring switching
- Childproofing feature
- Cooking zone timers
- Timer
- Pause function
- automatic heat up function
- Demo mode

## Scope of delivery

- Hyper cooktop, 1-ring/2-ring PKCH3 / PKCH3AB
- 2 x control knobs
- 2 x connection cables for the control knobs
- Connection cable to the extractor
- operating and installation instructions
- mounting straps
- height adjustment plate set
- power supply cable (1,5m)

## Product- and planning instructions

- Rotation by 180° possible during installation
- Ensure sufficient ventilation of the area below the cooktop.