

EN Operating and installation instructions
PKA/PKAS, PKASAB

BORA Pro Cooktop extractor

BORA Pro cooktop extraction system with integrated extractor

All Black BORA Pro cooktop extractor system with built-in fan

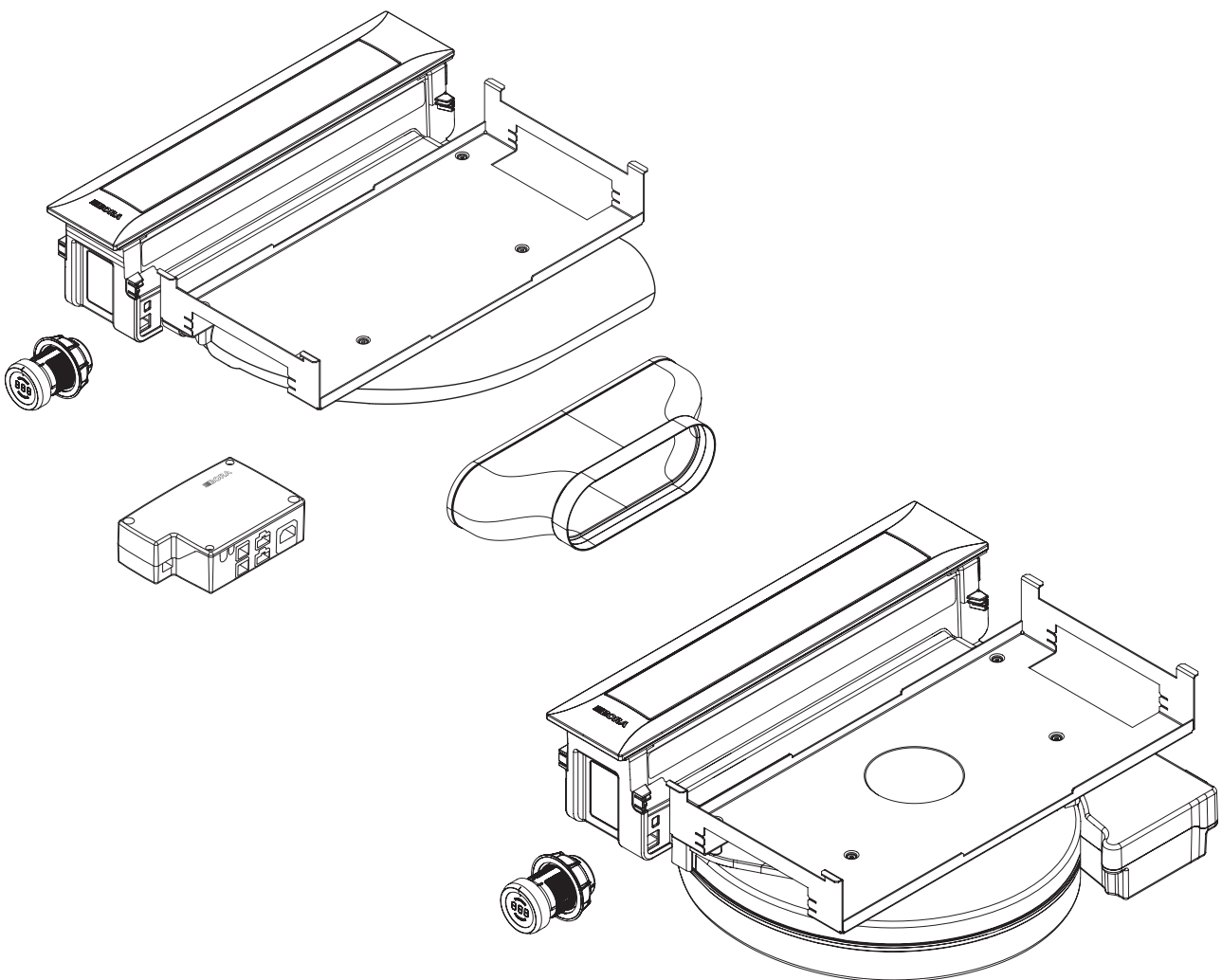

PKA1UMEN-005

Operating and installation instructions:

Original

Translation

Manufacturer

BORA Vertriebs GmbH & Co KG

Innstraße 1
6342 Niederndorf
Austria

Contact

T +43 (0) 5373 / 62250-0

mail@bora.com

www.bora.com

The distribution and duplication of this document, as well as the use and disclosure of its contents are prohibited unless expressly authorised.

These operating and installation instructions have been drawn up with the greatest of care. But it cannot be ruled out that subsequent technical modifications have not yet been incorporated or the relevant content has not yet been adapted. Please accept our apologies in this eventuality. An updated version can be requested from the BORA Service Team. Subject to printing errors and mistakes.

© BORA Vertriebs GmbH & Co KG

All rights reserved.

Table of Contents

1	General information	4	6.8.2	Connect the duct system to the device.....	25
1.1	Target group.....	4	6.8.3	Standard setup PKA.....	25
1.2	Validity of the operating and installation instructions.....	4	6.8.4	Installing the additional fan.....	26
1.3	Other applicable documents.....	4	6.9	Operating the cooktop extractor with a fireplace that depends on the air in the room.....	26
1.4	Presentation of information.....	5	6.10	Connecting external switch contacts.....	26
2	Safety	6	6.11	Establishing communication and power connection..	28
2.1	General safety instructions.....	6	6.11.1	Connecting the control knob.....	29
2.2	Safety instructions – Cooktop extractor.....	7	6.11.2	PKAS and PKASAB connections.....	29
2.3	Safety Instructions – Installation.....	7	6.11.3	PKA connection.....	29
2.4	Safety instructions – Cleaning and Maintenance.....	8	6.11.4	Establishing the power connection.....	30
2.5	Safety instructions – disassembly and disposal.....	9	6.12	Configuration menu.....	30
2.6	Safety instructions – spare parts.....	9	6.12.1	Accessing the configuration menu.....	30
2.7	Use as intended.....	9	6.12.2	Select menu option.....	31
3	Technical data	10	6.12.3	Changing the setting.....	32
3.1	PKA.....	10	6.12.4	Exiting configuration menu.....	32
3.2	PKAS, PKASAB.....	11	6.13	Handover to user.....	32
3.3	Control knob.....	11	7	Operation	33
4	Energy consumption label	12	7.1	General operating instructions.....	33
5	Device description	13	7.2	Operating the cooktop extractor.....	33
5.1	Type descriptions.....	13	7.2.1	Switching on the cooktop extractor.....	33
5.2	Structure.....	13	7.2.2	Automatic cooktop extractor function.....	33
5.2.1	Cooktop extractor PKA.....	13	7.2.3	Switching off the cooktop extractor.....	34
5.2.2	Cooktop extractor system PKAS, PKASAB.....	13	7.2.4	Automatic after-run.....	34
5.2.3	Grease filter components.....	14	7.2.5	Childproofing feature.....	34
5.2.4	Control knob.....	14	7.2.6	Crush protection.....	34
5.3	Operating principle.....	14	7.3	Note the filter service function.....	34
5.4	Functional principle of the cooktop extractor.....	15	8	Cleaning and maintenance	36
5.4.1	Power control.....	15	8.1	Cleaning agents.....	36
5.4.2	Power setting.....	15	8.2	Cleaning the cooktop extractor.....	36
5.4.3	Automatic cooktop extractor function.....	15	8.2.1	Cleaning position for cover flap.....	36
5.4.4	Sensors.....	15	8.2.2	Removing the cover flap, the grease filter and the filter tray.....	36
5.4.5	Automatic after-run.....	15	8.2.3	Fitting the cover flap, the grease filter and the filter tray.....	37
5.4.6	Filter service display.....	15	8.2.4	Removing the maintenance tray.....	37
5.4.7	Interface communication.....	15	8.2.5	Fitting the maintenance tray.....	38
5.4.8	Safety shut-down.....	15	8.2.6	Cleaning of the components.....	38
5.4.9	Crush protection.....	15	8.2.7	Finish cleaning the cooktop extractor.....	38
6	Installation	16	8.3	Cleaning the control knobs.....	38
6.1	Checking the scope of delivery.....	16	8.3.1	Cleaning the knob ring.....	38
6.2	Tool and aids.....	16	8.3.2	Cleaning the touch surface and the knob housing.....	38
6.3	Assembly instructions.....	17	8.4	Replacing the activated charcoal filter.....	39
6.3.1	Safety clearances.....	17	9	Troubleshooting	40
6.3.2	Worktop and kitchen units.....	17	10	Decommissioning, disassembly and disposal	41
6.4	Cut-out dimensions.....	17	10.1	Decommissioning.....	41
6.4.1	Flush installation.....	17	10.2	Disassembly.....	41
6.4.2	Surface mounting.....	18	10.3	Environmentally-friendly disposal.....	41
6.5	Installing the cooktop extractor.....	18	11	Warranty, technical service, spare parts, accessories	42
6.5.1	Installation dimensions.....	18	11.1	BORA manufacturer's warranty.....	42
6.5.2	Fitting the cooktop extractor.....	19	11.1.1	Warranty extension.....	42
6.5.3	Securing the cooktop extractor.....	19	11.2	Service.....	42
6.5.4	Duct connection dimensions.....	21	11.3	Spare parts.....	42
6.6	Installing the control knob into the floor unit front panel.....	21	11.4	Accessories.....	43
6.6.1	Bore hole.....	21			
6.6.2	Fitting the control knob.....	22			
6.7	PKA planning options.....	22			
6.7.1	Airflow straight to the side.....	22			
6.7.2	Airflow to left (installation rotated around 180°).....	23			
6.8	Installing the duct system.....	24			
6.8.1	Preparing for installation.....	24			

1 General information

1.1 Target group

These operating and installation instructions apply for the following target groups:

Target group	Requirements
User	The appliance can be used by children aged 8 and above as well as people with reduced physical, sensory or mental capacities or a lack of experience and/or knowledge if they are supervised or have been instructed how to safely use the appliance and understand the resultant risks. Children must be supervised. All safety and warning information and the handling instructions in the installation instructions must be complied with.
Ambitious DIYers	Ambitious DIYers can independently conduct all joinery and installation work providing they possess the necessary skills and expertise. They must never independently establish electricity and gas connections.
Installation specialists	Installation specialists are authorised to conduct all joinery and installation work in line with existing regulations. The electricity and gas connections must be certified by a certified engineer for the applicable trade prior to commissioning.
Electricians	The electrical connection may only be established by a certified engineer. He/she also assumes responsibility for the proper electrical installation and commissioning.
Gas specialists	The gas connection may only be established by certified engineers. They also assume responsibility for proper installation and commissioning of the gas system.

Tab. 1.1 Target groups

INFO BORA Holding GmbH, BORA Vertriebs GmbH & Co KG, BORA APAC Pty Ltd and BORA Lüftungstechnik GmbH - hereinafter referred to as BORA - do not assume any liability for damage arising from non-adherence to these documents and from improper assembly! The electricity and gas connections must be made by a qualified specialist. Installation must comply with the valid standards, regulations and laws. All safety and warning information and the operating and installation instructions must be complied with.

1.2 Validity of the operating and installation instructions

These instructions apply to several device versions. It is therefore possible that some of the features described do not apply to your appliance.

1.3 Other applicable documents

These operating and installation instructions are valid in conjunction with other documents, which must be adhered to.

Please be sure to adhere to all documents that form part of the scope of delivery.

INFO BORA accepts no liability for damage caused by failure to comply with these documents!

Directives

This device meets the following EU/EC directives:

2014/30/EU EMC Directive

2014/35/EU Low Voltage Directive

2009/125/EC Ecodesign Directive

2010/30/EU Energy Consumption Label Directive

2011/65/EU RoHS Directive

2012/19/EU WEEE Directive

1.4 Presentation of information

To make working with these instructions quick and easy, consistent formatting, numbering, symbols, safety instructions, terms and abbreviations are used throughout.

Handling instructions are marked with an arrow.

- ▶ Always carry out handling instructions in the sequence shown.

Bullet points are indicated by a square bullet point at the edge of the line.

- Bullet point 1
- Bullet point 2

INFO Information points out specific points you must always comply with.

Safety and warning information

The safety and warning information in these instructions are highlighted with symbols and signal words.



Safety and warning information is structured as follows:

WARNING SYMBOL AND SIGNAL WORD!

- Type and source of the danger
 - Consequences of non-compliance
 - ▶ Measures to minimise risk
-

The following applies:

- The warning symbol draws attention to the danger.
- The signal word indicates the severity of the risk.

Warning sign	Signal word	Hazard
	Danger	Indicates an imminent hazardous situation which could lead to death or serious injury if ignored.
	Warning	Indicates an imminent hazardous situation which could lead to death or serious injury if ignored.
	Caution	Indicates a potentially hazardous situation which could lead to slight or minor injuries if ignored.
–	Caution	Indicates a situation which could result in material damage if ignored.

Tab. 1.2 Meaning of warning symbols and signal words

2 Safety

2.1 General safety instructions

INFO The appliance complies with the stipulated safety requirements. The user is responsible for appliance cleaning and maintenance as well as its safe use. Improper use can lead to personal injury and damage to property.

- The operating and installation instructions contain important information about installation and operation. These enable you to protect yourself against injuries and prevent damage to the appliance. Contact details for further information as well as application and usage questions can be found on the back of these operating and installation instructions.
- The term “appliance” is used to refer to cooktops, cooktop extractors or cooktops with integrated cooktop extractor.
 - ▶ Read the operating and installation instructions fully before using the appliance for the first time.
 - ▶ Always store the operating and installation instructions within easy reach so that they can be accessed if required.
 - ▶ Pass the operating and installation instructions to the next owner if you sell the appliance.
 - ▶ Conduct all work extremely attentively and conscientiously.
 - ▶ Check the appliance for visible damage when unpacking it.
 - ▶ Do not connect a damaged appliance.
 - ▶ Do not connect the appliance to the mains until the duct system has been installed or the recirculation filter has been fitted.
 - ▶ Only use the connection cables supplied in the scope of delivery.
 - ▶ Do not use the appliance until installation is complete. This is the only way to ensure safe operation.
 - ▶ Make sure contact with hot cooking surfaces is not possible.
 - ▶ Do not place any objects on the operating panel or the cooktop extractor air inlet nozzle.
 - ▶ Switch off the appliance after use.
 - ▶ Keep pets away from the appliance.

Unauthorised modifications

Unauthorised modifications can cause the appliance to pose risks.

- ▶ Do not make any changes to the appliance.

Households with children and people with special needs

- ▶ The appliance can be used by children aged 8 and above as well as people with reduced physical, sensory or mental capacities or a lack of experience and/or knowledge if they are supervised or have been instructed how to use the appliance safely and understand the resultant risks.
- ▶ Supervise children in the vicinity of the appliance.
- ▶ Children must not play with the appliance.
- ▶ Do not store any items that could be of interest to children in storage spaces above or behind the appliance. Otherwise, they will be tempted to climb onto the appliance.

Recirculation mode

INFO When cooking, additional moisture is released into the ambient air.

INFO In recirculation mode, only a slight amount of moisture is removed from the cooking vapour.

- ▶ When using recirculation mode, ensure a sufficient supply of fresh air, e.g. by opening a window.
- ▶ Ensure a normal and comfortable room climate (humidity of 45–60%), e.g. by opening natural ventilation openings or using domestic ventilation systems.
- ▶ After every use in recirculation mode, switch the cooktop extractor to a low level for about 20 minutes or activate the automatic after-run function.

2.2 Safety instructions – Cooktop extractor

- ▶ Only operate the integrated cooktop extractor with BORA cooktops. This particularly applies to BORA gas cooktops.



DANGER!

Risk of smoke inhalation!

Using a fireplace that depends on the air in the room produces combustion gases.

If the cooktop extractor is used in conjunction with a fireplace that depends on the air in the room, toxic combustion gases (carbon monoxide) can be extracted from the chimney or outlet duct into the living area.

- ▶ Make sure that there is always a sufficient air supply.



DANGER!

Fire risk from flambéing!

While the cooktop extractor is working, it sucks up grease from cooking. Flambéing food can cause the grease to catch fire.

- ▶ Clean the cooktop extractor regularly.
- ▶ Never work with a naked flame while the cooktop extractor is running.



DANGER!

Fire risk from fat deposits!

If the stainless steel grease filter is not cleaned regularly, this can lead to increased levels of grease in it. This increases the fire risk.

- ▶ Clean and replace the filter at regular intervals.



WARNING!

Risk of injury due to moving fan wheel!

There is a risk of injury while the fan is turning.

- ▶ Only install the device with the power disconnected.
- ▶ Connect both sides of the fan to the duct system before commissioning.
- ▶ Ensure that the inlet nozzle is locked before the device is commissioned for the first time.

CAUTION!

Risk of injury from moving cover flap!

There is a risk of injury when the electrical cover flap is moving.

- ▶ Do not put your hands inside the cooktop extractor while the cover flap is moving.



CAUTION!

Exposed parts may become hot!

The cooktop extractor and its exposed parts are hot when the cooking zone is switched on and during the cooling phase.

- ▶ Please use suitable tools (pot holders, oven gloves).

CAUTION!

Damage caused by objects or paper suctioned in!

Small and light items, such as cleaning cloths made from material or paper, can be suctioned into the cooktop extractor. This can damage the fan or impair the exhaust performance.

- ▶ Do not store any items or paper on the cooktop extractor.

CAUTION!

Damage caused by grease and dirt deposits!

Grease and dirt deposits can prevent the cooktop extractor from functioning properly.

- ▶ Never use the cooktop extractor without a stainless steel grease filter.

2.3 Safety Instructions – Installation

The appliance must only be installed and assembled by trained specialists who are familiar with and comply with the standard national regulations and supplementary regulations of the local utility companies.

Work on electrical components must be conducted by trained electrical personnel.

The electrical safety of the appliance is only guaranteed if it is connected to a protective conductor system that has been installed in line with regulations. Ensure that this basic safety precaution is met.

- ▶ Check the appliance for visible damage prior to installation.
- ▶ Do not install any damaged appliance.
- A damaged appliance may put your safety at risk.

Repair and maintenance work may only be carried out by specialists authorised by the manufacturer.



DANGER!

Risk of asphyxiation!

Packaging components (e.g. film, polystyrene) can be life-threatening for children.

- ▶ Store all packaging components out of reach of children.
- ▶ Dispose of the packaging properly and immediately.

2.3.1 Safety Instructions – Cooktop extractor



DANGER!

Risk of poisoning caused by combustion gases!

When the cooktop extractor is used in exhaust mode, it draws in air from the room it is installed in and from neighbouring rooms. Without sufficient air, there will be a drop in air pressure. Toxic gases could be drawn out of the chimney or extraction ducting on a fireplace that depends on the room air and back into the room.

- ▶ Make sure that there is always a sufficient air supply.
- ▶ Only use reliable, tried-and-tested switching devices, (e.g. window contact switch, low pressure warning device) and have them approved by a qualified expert (certified chimney sweep).



DANGER!

Risk of electric shock!

The control unit can contain residual charge and cause an electric shock.

- ▶ Do not touch exposed contacts on the control unit.



DANGER!

Risk of electric shock!

Incorrect stripping of the connection cable to external switching devices results in a risk of electric shock.

- ▶ Ensure that the connection cable is secured with the strain relief clamp within the universal control unit.
- ▶ Ensure that the stated stripping lengths are adhered to.

Special safety information for exhaust systems

- ▶ Please pay attention to the channel length between the fan and the wall sleeve in straight channel design.
- A minimum space of 90 cm between the blow out opening of the fan and the blow out opening of the wall sleeve must be planned in.

2.4 Safety instructions – Cleaning and Maintenance

The appliance must be cleaned at regular intervals. Dirt can lead to damage or bothersome odours. Remove dirt immediately.

- Any work involving cleaning and maintenance must not be carried out by children unless they are supervised at all times while doing so.
- ▶ Do not use a steam cleaner for cleaning. Steam can cause a short circuit on live parts and thus lead to property damage (see the Cleaning and Maintenance chapter).
- ▶ When cleaning, ensure that no water penetrates the appliance. Use only a slightly damp cloth. Never spray the device with water. Water penetration can cause damage!

CAUTION!

Risk of injury when inserting the grease filter!

Injuries can be caused if the hands slip while inserting the grease filter into the cooktop extractor.

- ▶ When inserting the grease filter, only ever hold it by the handle provided.

2.5 Safety instructions – disassembly and disposal

The appliance must only be disassembled by trained specialists who are familiar with and comply with the standard national regulations and supplementary regulations of the local utility companies.

Work on electrical components must only be conducted by trained electrical personnel.



DANGER!

Risk of electric shock!

Incorrectly disconnecting the appliance from the mains results in a risk of electric shock.

- ▶ Securely disconnect the appliance from the mains using LS switches, fuses, automatic circuit breakers or contactors.
- ▶ Use an authorised measuring device to ensure that there is no power to the appliance.
- ▶ Do not touch exposed contacts on the electronic unit as they can contain residual charge.

2.6 Safety instructions – spare parts



WARNING!

Risk of injury and damage to property!

Incorrect components can lead to personal injury or damage to the appliance. Modifications, additions or alterations to the appliance can lead to safety risks.

- ▶ Only use original spare parts for repairs.

INFO

A damaged power supply cable must be replaced by a suitable power supply cable. This may only be done by an authorised member of the After Sales Service team.

2.7 Use as intended

The appliance cannot be used at altitudes above 2,000 m (metres above sea level).

The appliance is solely intended for preparing food in private households. This appliance is not intended for:

- Outdoor use
- Installation in vehicles
- Heating rooms
- Use in non-stationary installation sites (e.g. on ships)
- Use with an external timer or a separate remote control system (remote operation)

Any use other than that specified in these operating and installation instructions or any use that goes beyond that which is described here is classed as unintended. BORA does not assume any liability for damages caused by improper use or incorrect operation.

All misuse is prohibited!

INFO

BORA Holding GmbH, BORA Vertriebs GmbH & Co KG, BORA APAC Pty Ltd and BORA Lüftungstechnik GmbH do not assume any liability for damage arising from non-adherence to the safety and warning information.

3 Technical data

3.1 PKA

Parameter	Value
Supply voltage	220 - 240 V
Frequency	50/60 Hz
Power consumption (including external BORA universal article fans)	max. 700 W
Dimensions (width x depth x height)	482 x 540 x 176 mm
Dimension of control knob (diameter x depth)	Ø 49 mm Ø 92 mm
Weight (incl. accessories/packaging)	9.25 kg
Cooktop extractor	
Power levels	1 - 9, P

Tab. 3.1 Technical data PKA

Device dimensions PKA

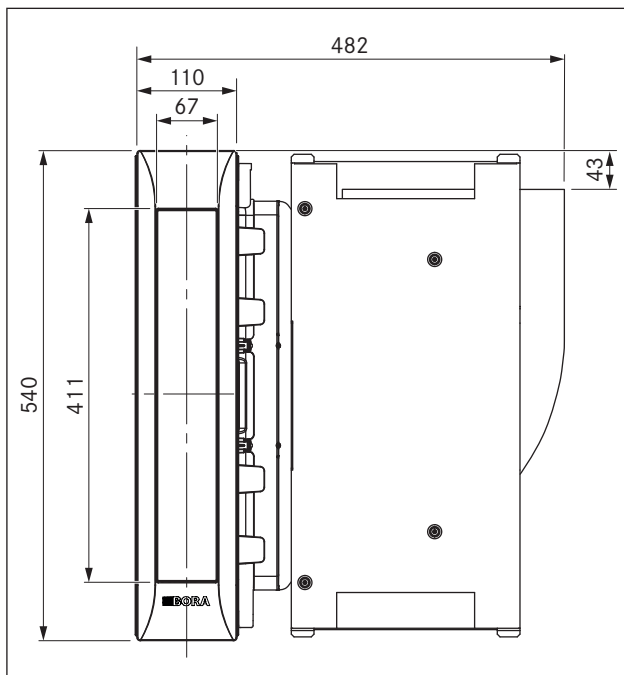

Fig. 3.1 PKA Device dimensions aerial view

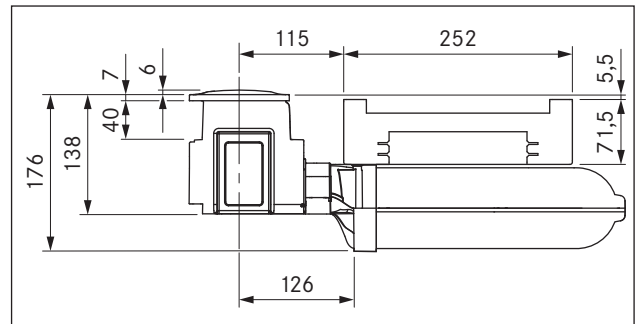

Fig. 3.2 PKA Device dimensions front view

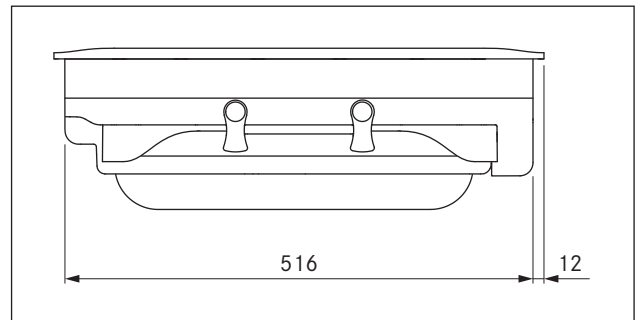

Fig. 3.3 PKA Device dimensions side view

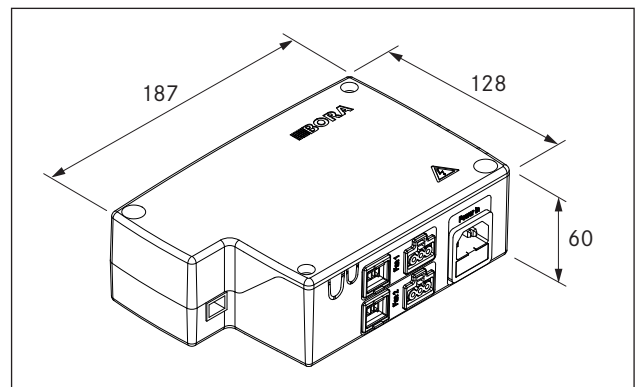

Fig. 3.4 Universal control unit device dimensions

3.2 PKAS, PKASAB

Parameter	Value
Supply voltage	220 - 240 V
Frequency	50/60 Hz
Power consumption (including external BORA universal article fans)	max. 700 W
Power consumption of internal motor	max. 170 W
Dimensions (width x depth x height)	468 x 540 x 199 mm
Dimension of control knob (diameter x depth)	Ø 49 mm Ø 92 mm
Weight (incl. accessories/packaging)	12.5 kg
Cooktop extractor	
Power levels	1 - 9, P

Tab. 3.2 Technical data PKAS, PKASAB

Device dimensions PKAS, PKASAB

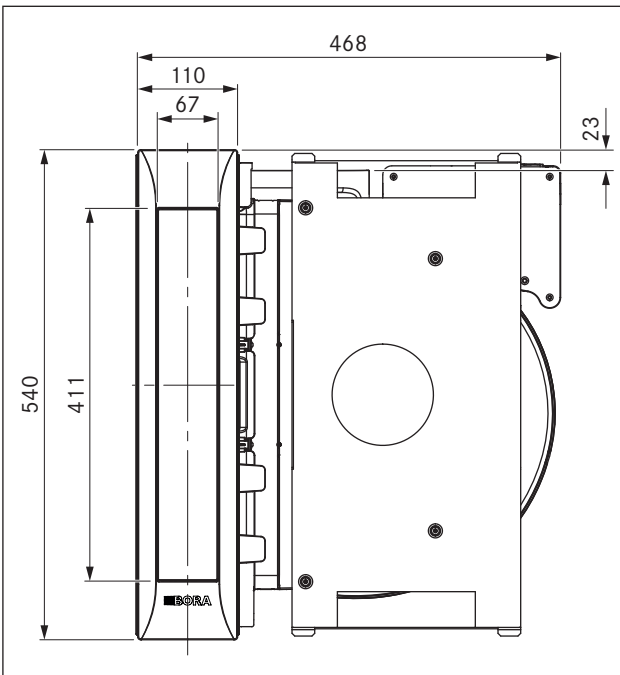

Fig. 3.5 PKAS, PKASAB Device dimensions aerial view

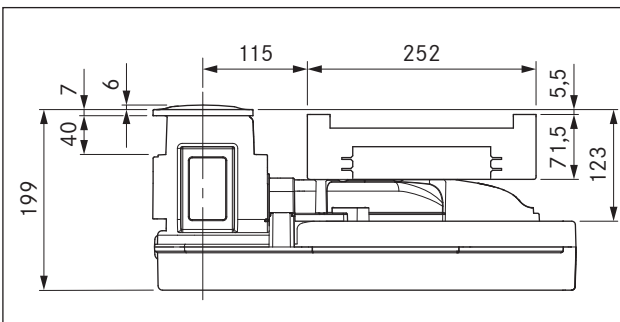

Fig. 3.6 PKAS, PKASAB Device dimensions front view

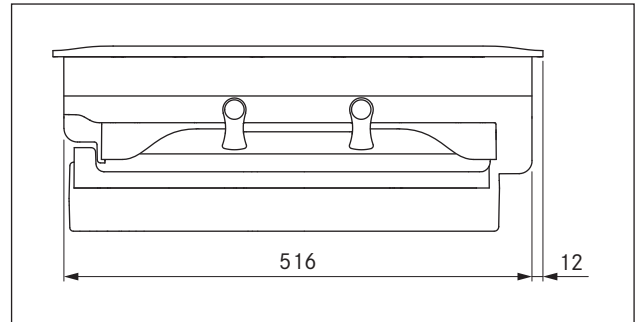

Fig. 3.7 PKAS, PKASAB Device dimensions side view

3.3 Control knob

Device dimensions control knob

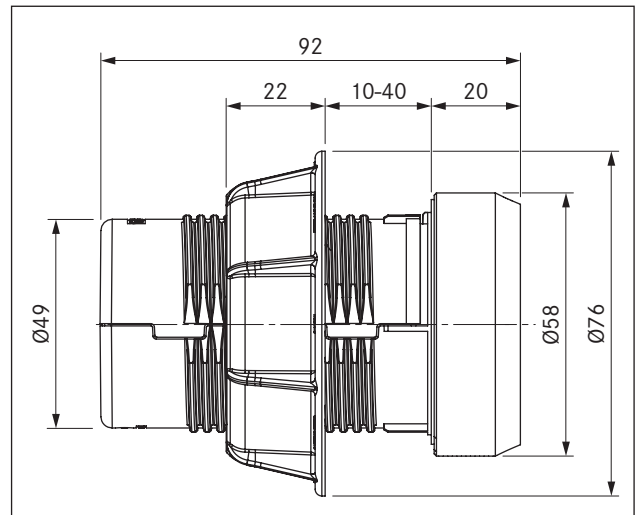

Fig. 3.8 Device dimensions control knob

4 Energy consumption label

Product description	Professional cooktop extractor PKA	Professional cooktop extractor system PKAS, PKASAB	
Operating mode	Exhaust air	Exhaust air	
Energy consumption	Value	Value	EN standard
Annual energy consumption (AEC_{hood})	23.4 kWh/a	32.5 kWh/a	61591
Energy efficiency class	A++	A+	61591
Energy efficiency index (EEl_{hood})	31.6	42.5	61591
Flow volume			
Fluid dynamic efficiency (FDE_{hood})	38.4	34.5	61591
Fluid dynamic efficiency class	A	A	61591
Minimum air flow	276.9 m ³ /h	251.7 m ³ /h	61591
Maximum air flow	612.7 m ³ /h	618.2 m ³ /h	61591
Air flow power setting (Q_{Max})	612.7 m ³ /h	689.8 m ³ /h	61591
Lighting			
Lighting efficiency (LE_{hood})	* lx/Watt	* lx/Watt	*
Lighting efficiency class	*	*	*
Grease filtering			
Maximum level (no power setting) (GFE_{hood})	86.8 %	91.28 %	61591
Class maximum level	B	B	61591
Sound power level			
minimum	42.5 dB(A)	47.6 dB(A)	60704-2-13
maximum	61.5 dB(A)	68.4 dB(A)	60704-2-13
Power setting	61.8 dB(A)	69.9 dB(A)	60704-2-13
Sound pressure level (additional details)			
minimum	29.2 dB(A)	34.9 dB(A)	**
maximum	48.2 dB(A)	55.7 dB(A)	**
Power setting	48.5 dB(A)	57.2 dB(A)	**
Details according to 66/2014			
Time increase factor	0.6	0.8	61591
Electric power input at the best efficiency point (W_{BEP})	106.9 W	111.3 W	61591
Pressure at the best efficiency point (P_{BEP})	518 Pa	418 Pa	61591
Air flow rate at the best efficiency point (Q_{BEP})	288.1 m ³ /h	330.7 m ³ /h	61591
Power consumption in off mode (P_o)	0.4 W	0.43 W	61591

Tab. 4.1 Information on the energy consumption label in accordance with Ordinance (EU) no. 65/2014 or 66/2014.

* This specification is not applicable for this product.

** The sound pressure level has been determined from a distance of 1m (distance-dependent level recording) on the basis of the sound power level established in EN 60704-2-13.

5 Device description

Observe all safety and warning information during operation (see the Safety section).

The cooktop extractor has the following features:

- Power control via a control knob
- Power display
- Electrical cover flap with position sensor
- Stainless steel grease filter
- Grease filter position sensor
- Automatic cooktop extractor function
- Automatic after-run
- Filter service display
- Interface for external devices
- Safety shut-down
- Cover flap crush protection

Depending on the model you purchased, the cooktop extractor can be operated as an exhaust air or an recirculating air version.



Exhaust mode

The air extracted is cleaned by the stainless steel grease filter and released outside through a duct system.

The exhaust air must not be expelled into:

- a smoke or exhaust gas flue that is in operation
- a shaft used for the aeration of rooms where fireplaces are installed.

If the exhaust air is to be directed into a smoke or exhaust gas flue that is not in use, the installation must be checked and approved by the responsible heating engineer.



Recirculation mode

The air extracted is purified by the grease filter and an activated charcoal filter and fed back into the room in which the appliance is installed.

To prevent odours in recirculation mode, an odour filter must be used. For hygiene and health reasons, the activated charcoal filter must be replaced at the recommended intervals (see the Cleaning and maintenance section).

INFO In recirculation mode, ensure sufficient ventilation and aeration to expel humidity.

5.1 Type descriptions

PKA = Professional cooktop extractor with separate control unit and freely combinable fans

PKAS, PKASAB = Professional cooktop extractor system with built-in control unit and built-in fans

5.2 Structure

5.2.1 Cooktop extractor PKA

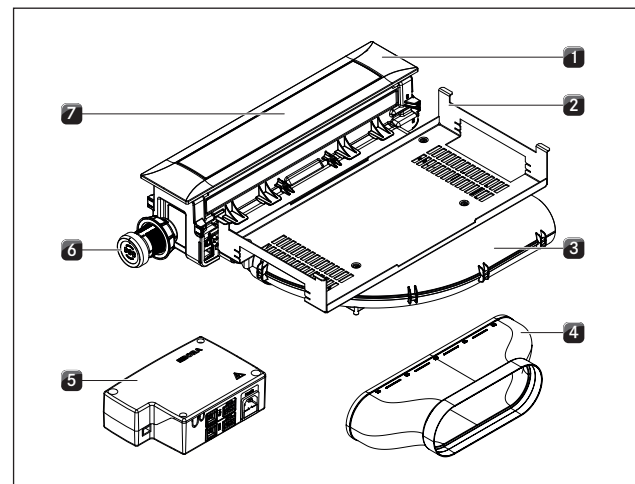

Fig. 5.1 Cooktop extractor PKA

- [1] cover frame
- [2] Holding plate
- [3] Bent ducting piece
- [4] Straight ducting piece
- [5] Universal control unit
- [6] Control knob
- [7] Cover flap

5.2.2 Cooktop extractor system PKAS, PKASAB

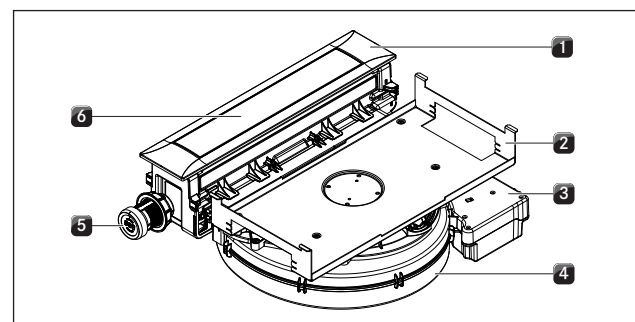

Fig. 5.2 Cooktop extractor system PKAS, PKASAB

- [1] cover frame
- [2] Holding plate
- [3] Control unit
- [4] Fan housing with fan
- [5] Control knob
- [6] Cover flap

5.2.3 Grease filter components

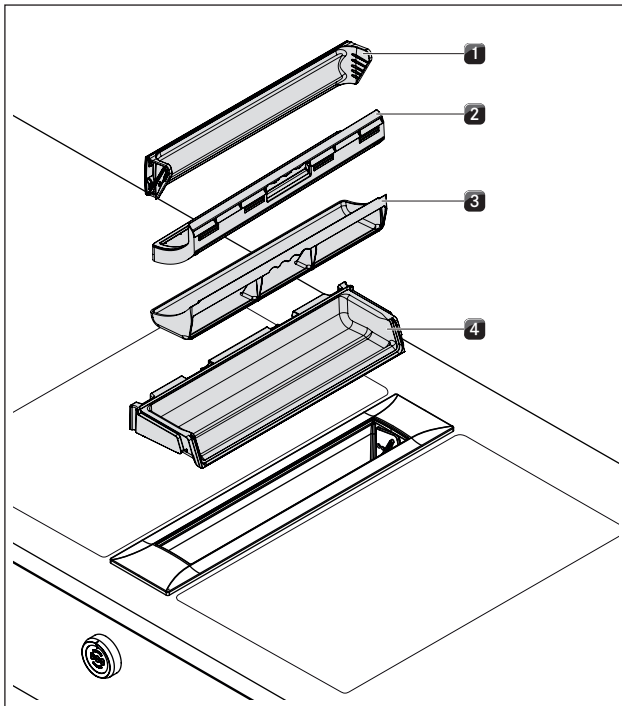

Fig. 5.3 Grease filter components

- [1] Cover flap
- [2] Stainless steel grease filter
- [3] Filter tray
- [4] Maintenance tray

5.2.4 Control knob

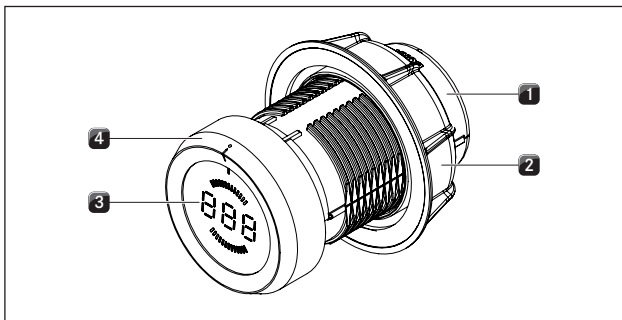

Fig. 5.4 Control knob

- [1] Knob casing
- [2] Universal nut
- [3] Control knob display
- [4] knob ring

5.3 Operating principle

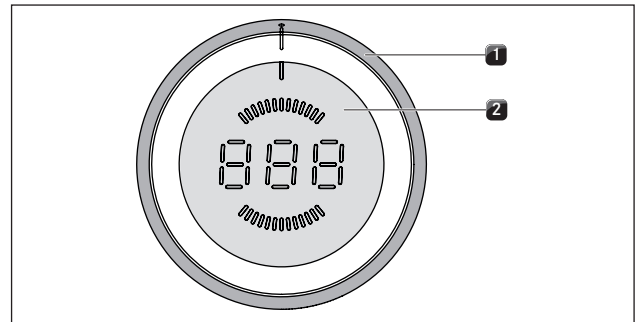

Fig. 5.5 Control elements of control knob

- [1] knob ring
- [2] Touch surface

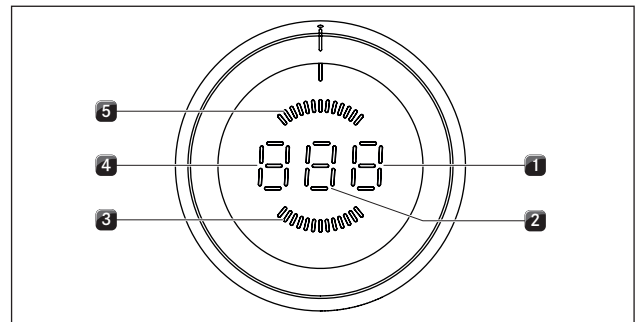

Fig. 5.6 Control knob display elements

- [1] Display of functions
- [2] Power display
- [3] Recirculation display
- [4] Display of mode or operating mode
- [5] Exhaust mode display

Control knob display	Meaning
<i>1 - 9</i>	Power levels
<i>P</i>	Power setting
<i>0</i>	Cooktop extractor is switched off
<i>R + Power level</i>	Extraction system
<i>n</i>	Automatic after-run
<i>L</i>	Childproofing feature active
<i>c</i>	Cleaning position for cover flap
<i>F</i> flashing	Filter service display
<i>E...</i>	Error message (see Troubleshooting section)
<i>E</i>	Configuration menu

Tab. 5.1 Meaning of display

Knob operation

The cooktop extractor is operated using a control knob. By twisting the control knob and pressing the touch surface, the power levels and functions are controlled (see Operation section).

5.4 Functional principle of the cooktop extractor

5.4.1 Power control

The power levels are controlled by turning the knob ring to the desired power level.

5.4.2 Power setting

The cooktop extractor has a power-enhancing power setting. This power setting makes it possible to suction away high levels of cooking vapours more quickly. After 9 minutes, the power setting is automatically switched to power level 9.

5.4.3 Automatic cooktop extractor function

The automatic cooktop extractor function adjusts the extraction performance automatically to the highest power level for all cooking zones connected.

Function	Power levels									
Cooking level	1	2	3	4	5	6	7	8	9	P
Extraction power	4	4	4	4	5	6	7	8	9	P

Tab. 5.2 Extraction performance and cooking level

- If the power level of the cooking zones is changed, the automatic cooktop extractor function adjusts the cooktop extractor performance after a 30 second delay.
- Once the cooking session is complete, the automatic after-run is activated.
- After the automatic after-run period, the cooktop extractor switches itself off automatically.

5.4.4 Sensors

The cooktop extractor is fitted with sensors near the cover flap and the grease filter.

Position sensor for cover flap

The cover flap sensor detects the position of the cover flap.

- If the cover flap is closed, the cooktop extractor is deactivated.
- If the cover flap is open, the cooktop extractor can be used.
- If the cover flap is removed, the cooktop extractor can be used.

Grease filter position sensor

The grease filter sensor detects whether the grease filter is properly fitted.

- If the grease filter is missing or fitted incorrectly, the cooktop extractor is deactivated.

INFO If the grease filter has been removed, for example for cleaning purposes, the cover flap can still be closed.

5.4.5 Automatic after-run

The cooktop extractor continues to run at a lower level and switches off automatically after 20 minutes.

5.4.6 Filter service display

The filter service display is active after 200, 300 or 400 operating hours, depending on the filter unit fitted. The activated charcoal filter has reached the end of its service life (with recirculation only) and the grease filter components need to be thoroughly cleaned.

- After the cooktop extractor is switched on, F flashes on the control knob display.
- The filter service display is shown every time the cooktop extractor is switched on and remains active until the filter has been changed and the filter service display has been reset.
- The cooktop extractor can still be operated without limitations.
- The filter service display can be deactivated on a one-off basis or completely reset in order to use the cooktop extractor.

INFO Irrespective of the filter service display, the grease filter components require regular cleaning (see Cleaning and maintenance section).

5.4.7 Interface communication

The internal interface can be used for extended control options. This has a 'Home In' and a 'Home Out' contact (see the Installation section).

- The 'Home In' contact can be used for the signal input from external switch devices (e.g. window contact switch).
- The 'Home Out' contact can be used to control external installations.

5.4.8 Safety shut-down

The cooktop extractor shuts down automatically after an operating time of 120 minutes with no changes in power level.

5.4.9 Crush protection

The electrical cover flap on the cooktop extractor has crush protection.

If the cover flap is blocked while it is opening or closing, the movement is stopped automatically. The cover flap moves back to its starting position (see Operation section).

6 Installation

- ▶ Observe all safety and warning information (see the Safety section).

INFO The device must not be installed above cooling devices, dishwashers, stoves, ovens, washing machines or dryers.

INFO The contact surfaces of the worktops and wall sealing strips must be made of a heat-resistant material (up to approx. 100 °C).

INFO Worktop cut-outs must be moisture-sealed using suitable means and, where necessary, fitted with a thermal insulator.

NFO Control knobs have to be connected only to the provided connections of the cooktop extractor.

6.1 Checking the scope of delivery

- ▶ Check the scope of delivery to make sure everything has been provided (see table (see Table 6.1 and 6.2).
- ▶ If there are any missing or damaged parts, please notify BORA After Sales Service.
- ▶ Do not under any circumstances install parts which are damaged.
- ▶ Dispose of transport packaging in the proper manner (see the Decommissioning, disassembly and disposal section).
- ▶ Adhere the supplied nameplate (adhesive label) to the back of your operating and installation instructions.

Scope of delivery PKA

Name	Quantity
Operating and installation instructions	1
Cooktop extractor	1
Height adjustment plate set	1
Mounting clamps	4
Control knob	1
Stainless steel grease filter	1
Filter tray	1
Maintenance tray	1
Cover flap	1
CAT 5 communication cable	1
Universal control unit	1
Power supply cable	1
Straight ducting piece	1
Control knob cable – interface/extractor 1000 mm	1

Tab. 6.1 Scope of delivery PKA

Scope of delivery PKAS, PKASAB

Name	Quantity
Operating and installation instructions	1
Cooktop extractor	1
Height adjustment plate set	1
Mounting clamps	4
Control knob	1
Stainless steel grease filter	1
Filter tray	1
Maintenance tray	1
Cover flap	1
Power supply cable	1
Control knob cable – interface/extractor 250 mm	1

Tab. 6.2 Scope of delivery PKAS, PKASAB

6.2 Tool and aids

The following tools are required to correctly install the cooktop extractor:

- Pencil
- Tape measure or metre rule
- Standard or cordless drill with Forstner bit Ø50 mm
- Black, heat-resistant silicone sealant
- Flat screwdriver
- Torx screwdriver size 20
- Torx screwdriver size 10 (PKA only)

6.3 Assembly instructions

6.3.1 Safety clearances

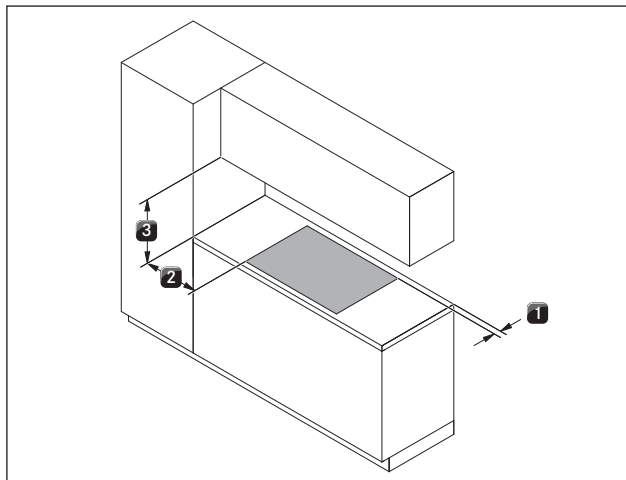

Fig. 6.1 Recommended minimum clearances

► Maintain the following safety clearances:

- [1] Rear minimum clearance of 50 mm between the worktop cut-out and the rear corner of the worktop.
- [2] Minimum clearance of 300 mm from the left and right of the worktop cut-out to the adjacent cabinet or wall.
- [3] Minimum clearance of 600 mm between the worktop and the wall unit.

6.3.2 Worktop and kitchen units

- Create the worktop cut-out taking into account the specified cut-out dimensions.
- Make sure that the cutting surfaces of the worktops are properly sealed.
- Comply with the instructions of the worktop manufacturer.
- Cross bars on the kitchen unit in the area of the worktop cut-out may need to be removed.
- No false floor is necessary below the cooktop. If cable protection (false floor) is planned, the following must be taken into account:
 - It must be fitted in such a way that it can be removed for maintenance work.
 - To ensure sufficient cooktop ventilation, a minimum distance of 15 mm to the bottom edge of the cooktop is to be observed.
- The drawers and/or shelves in the floor unit must be removable.
- A return flow aperture $> 500 \text{ cm}^2$ is required in the kitchen units for recirculation appliances (e.g. by shortening the plinth boards or using suitable slatted plinths).

6.4 Cut-out dimensions

INFO All dimensions from the front edge of the front cover.

Worktop overhang

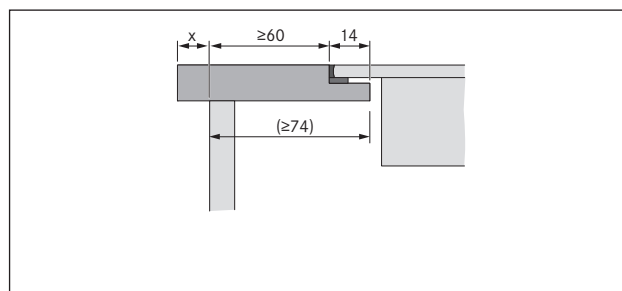

Fig. 6.2 Worktop overhang

- Please note the worktop overhang x when creating the worktop cut-out. Applies to flush installation and surface mounting.

INFO For cooktop extractor PKA used in conjunction with straight ducting piece PKA1FEV, flush mounting is also possible for worktop depths $\geq 650 \text{ mm}$.

6.4.1 Flush installation

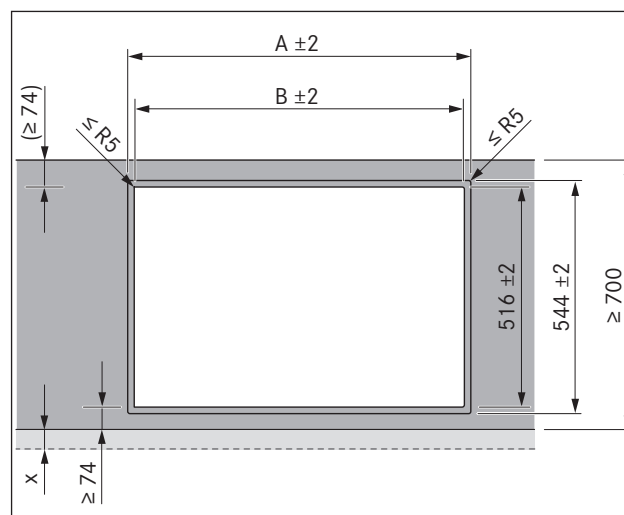

Fig. 6.3 Cut-out dimensions flush installation

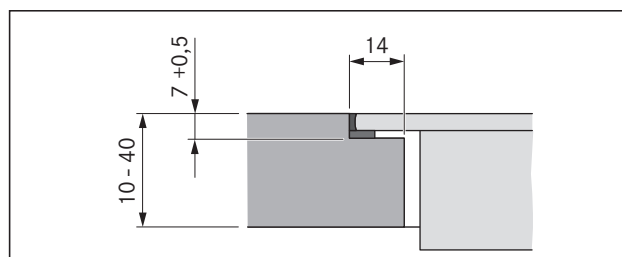

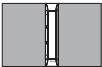
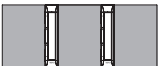







Fig. 6.4 Groove dimensions for flush installation

Cut-out dimensions when installing cooktops only or cooktops and the cooktop extractor next to each other:

Cooktops/cooktop extractor	A in mm	B in mm
	1/0	374
	1/1	485
	2/1	856
	3/2	1338
	4/2	1709

Tab. 6.3 Cut-out dimensions appliance combinations flush installation

Cut-out dimensions when installing cooktops only or cooktops and the cooktop extractor next to each other:

Cooktops/cooktop extractor	B in mm
	1/0
	1/1
	2/1
	3/2
	4/2

Tab. 6.4 Cut-out dimensions appliance combinations surface mounting

6.4.2 Surface mounting

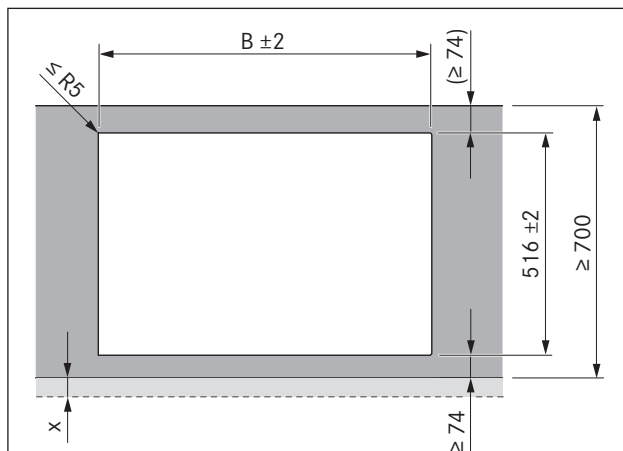

Fig. 6.5 Cut-out dimensions surface mounting

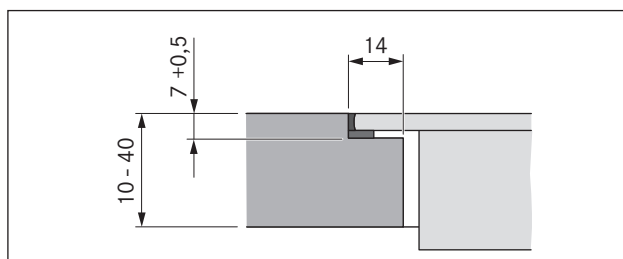

Fig. 6.6 Surface mounting cut-out

6.5 Installing the cooktop extractor

INFO Clearance of one millimetre should be planned between the built-in appliances. In combination with an adjacent PKIW1 induction wok cooktop, the plastic strip on the side of the cooktop extractor must be carefully removed for this.

INFO A clearance of two millimetres should be planned around the built-in appliances.

6.5.1 Installation dimensions

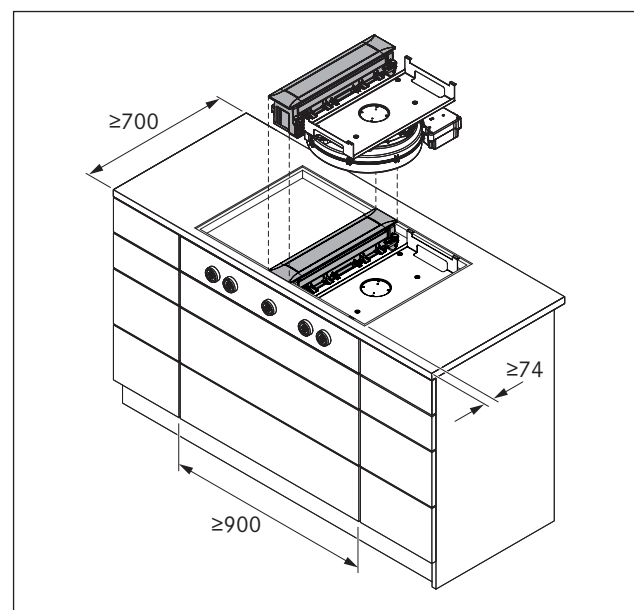

Fig. 6.7 PKA, PKAS and PKASAB device installation dimensions

6.5.2 Fitting the cooktop extractor

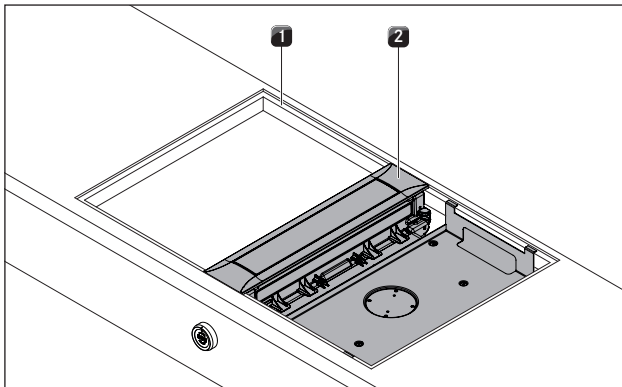

Fig. 6.8 Fitting the cooktop extractor

- [1] Worktop cut-out
- [2] Cooktop extractor

- ▶ Place the cooktop extractor [2] in the middle of the relevant worktop cut-out [1].
- ▶ Precisely position the cooktop extractor [2].

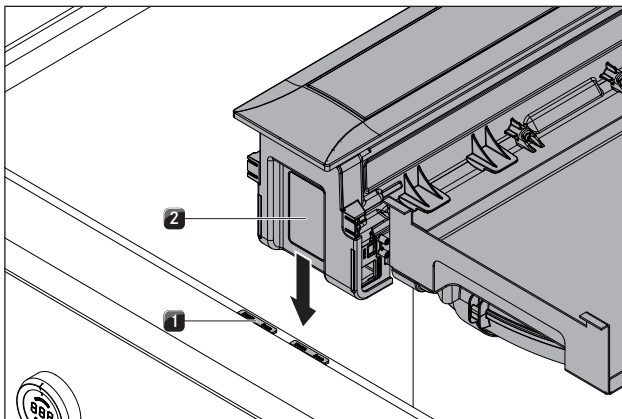

Fig. 6.9 Height adjustment plates

- [1] Height adjustment plate
- [2] Cooktop extractor

- ▶ If applicable, insert the height adjustment plates [1].

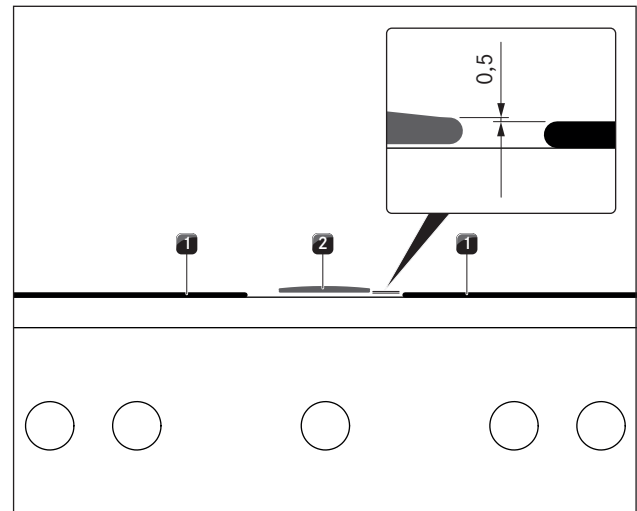

Fig. 6.10 Installing the cooktop extractor

- [1] Cooktop
- [2] Cooktop extractor

- The cooktop extractor [2] must be installed 0.5 mm higher than the cooktops [1].

6.5.3 Securing the cooktop extractor

The cooktop extractor is secured using the four mounting brackets provided. The mounting brackets have offset fastening lugs, with one side for surface mounting and one for flush mounting. The mounting clamps can be adjusted to the thickness of the worktop.

Preparing the mounting clamps

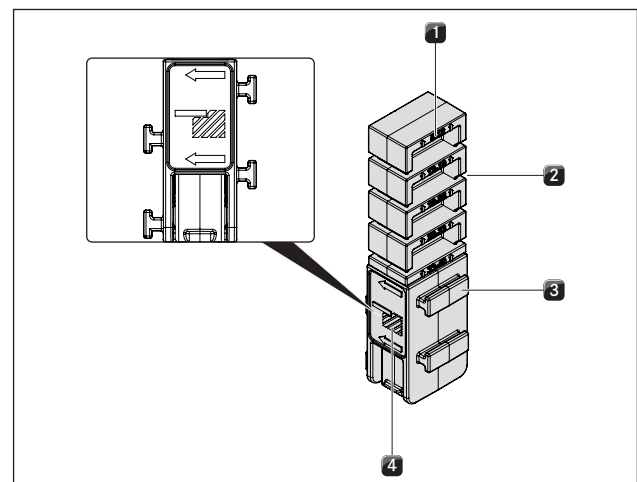

Fig. 6.11 Mounting clamp on right (flush mounting)

- [1] Worktop thickness labelling (in mm)
- [2] Cut mark (4x)
- [3] Fastening lugs (2 on each side)
- [4] Marking for flush mounting

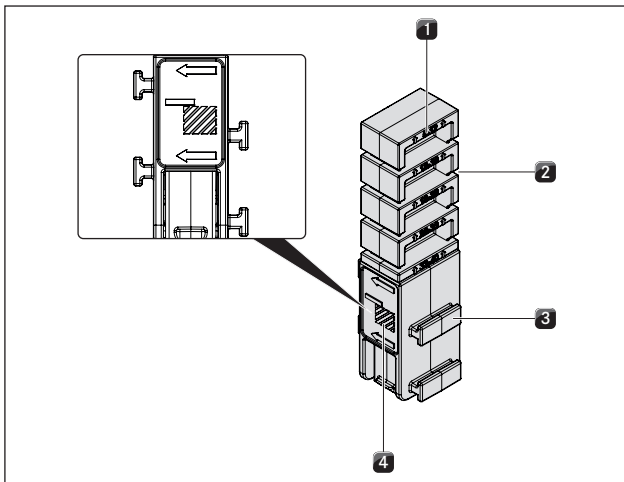

Fig. 6.12 Mounting clamp on left (surface mounting)

- [1] Worktop thickness labelling (in mm)
- [2] Cut mark (4x)
- [3] Fastening lugs (2 on each side)
- [4] Marking for surface mounting

INFO The symbols on the mounting clamps show which side to use for surface mounting and for flush-mounting.

INFO The labels shows the cutting mark to go with the worktop thickness.

- ▶ If necessary, shorten the mounting clamps in line with the worktop thickness.
- ▶ To do this, cut the mounting clamps at the appropriate cut marks using a cutter.
- ▶ Depending on the installation type, twist the mounting clamps to the left or right (flush mounting or surface mounting).

Securing the cooktop extractor

INFO The cooktop extractor is secured using the four mounting clamps provided, for which there are 4 alternative positions on the holding plate.

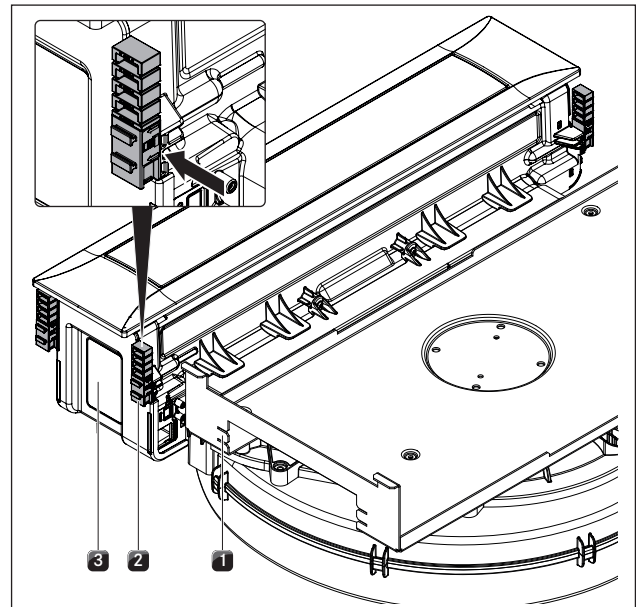

Fig. 6.13 Push on mounting clamps

- [1] Alternative position for mounting clamp
- [2] mounting clamp
- [3] Cooktop extractor

- ▶ Push the mounting clamps [2] into the holders provided on the cooktop extractor [3] or the alternative positions on the holding plate [1].

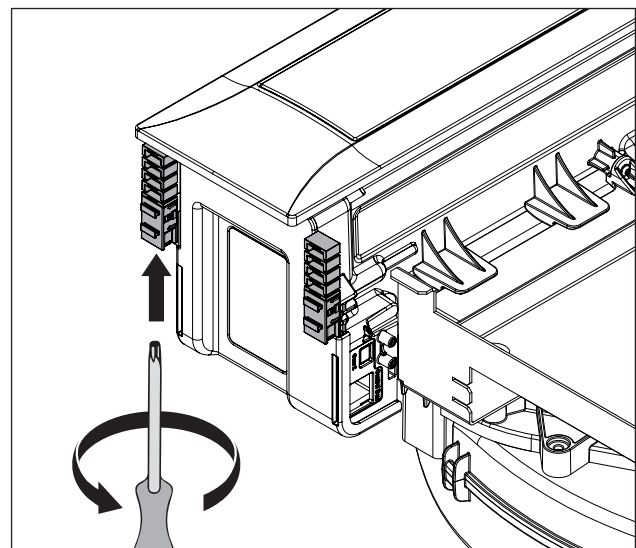

Fig. 6.14 Tighten the mounting clamps

- ▶ Use a Torx 20 screwdriver to tighten the mounting clamps slightly from underneath.
- ▶ Verify that the alignment is correct.

- Once all of the installation work is complete, seal the device with black, heat-resistant silicone sealant.

6.5.4 Duct connection dimensions

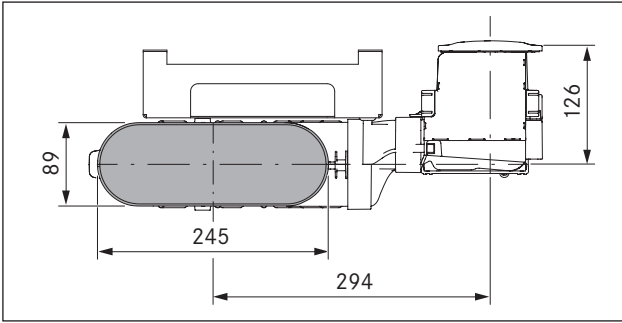

Fig. 6.15 PKA duct connection dimensions with angled ducting piece

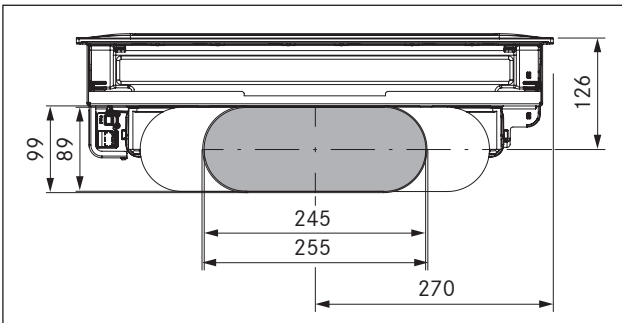

Fig. 6.16 PKA duct connection dimensions with straight ducting piece

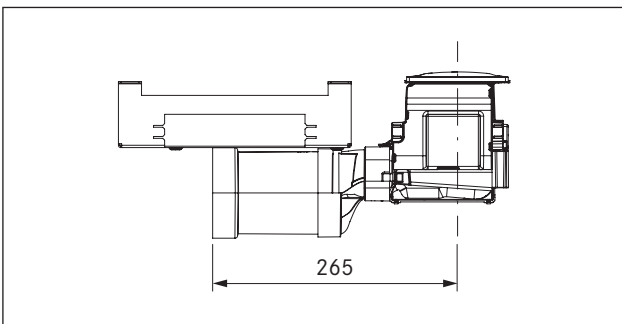

Fig. 6.17 PKA duct connection dimensions with straight ducting piece

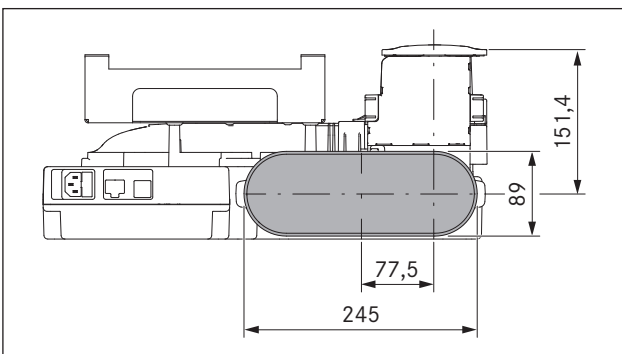

Fig. 6.18 PKAS, PKASAB duct connection dimensions

6.6 Installing the control knob into the floor unit front panel

6.6.1 Bore hole

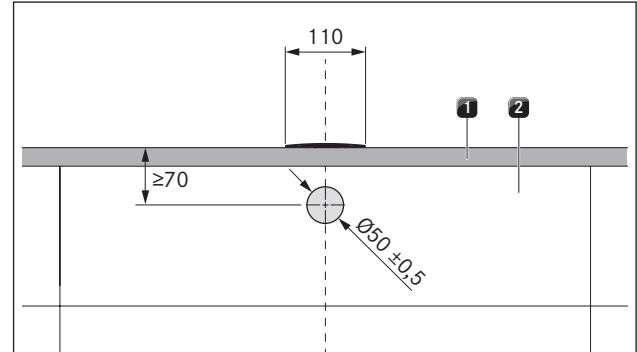

Fig. 6.19 Drill template

- [1] Worktop
- [2] Fixed front panel

- Pre-drill the bore hole to prevent tearing out the panel.

Example bore holes

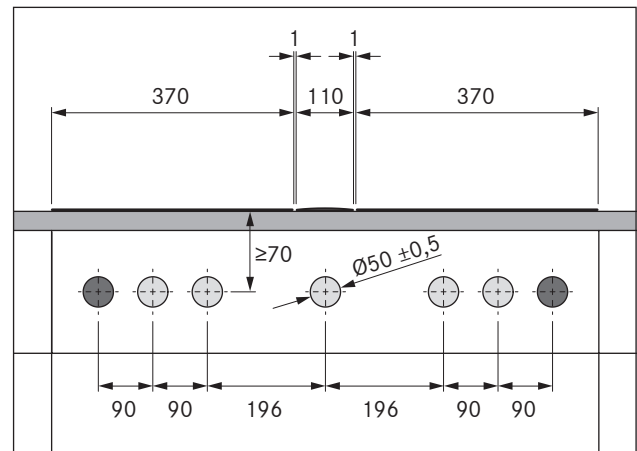

Fig. 6.20 Bore holes for 2 cooktops, 2 sockets and 1 cooktop extractor

- [1] Bore holes for socket (2x external)
- [2] Bore holes for control knobs (5x)
- [3] Cooktop 2x
- [4] Cooktop extractor
- [5] Worktop
- [6] Cover for the floor unit

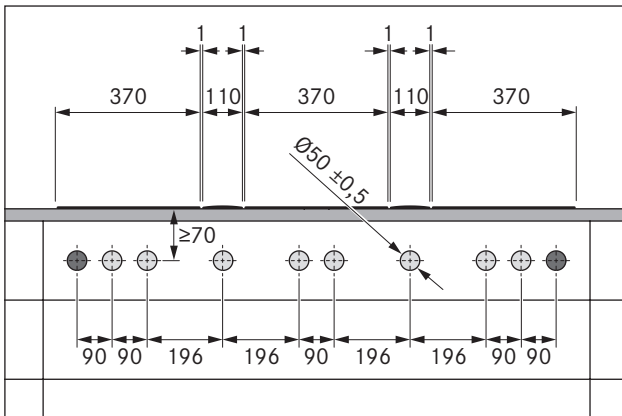

Fig. 6.21 Bore holes for 3 cooktops, 2 sockets and 2 cooktop extractors

- [1] Bore holes for socket (2x external)
- [2] Bore holes for control knobs (8x)
- [3] Cooktop 3x
- [4] Cooktop extractor (2x)
- [5] Worktop
- [6] Cover for the floor unit

6.6.2 Fitting the control knob

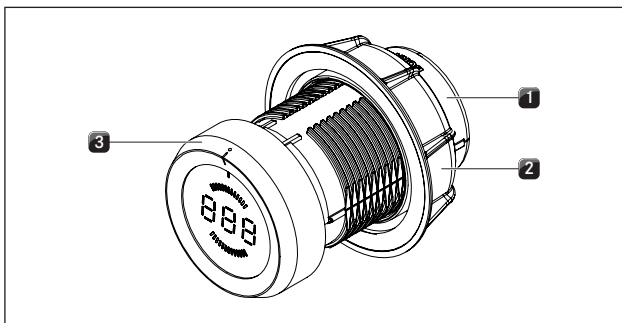

Fig. 6.22 Structure of control knob

- [1] Knob casing
- [2] Universal nut
- [3] knob ring

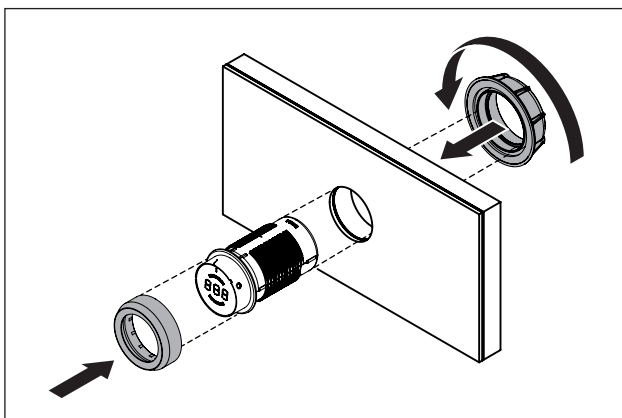

Fig. 6.23 Fitting the control knob

- ▶ Pull off the knob ring [3].
- ▶ Unscrew the universal nut [2].
- ▶ Push the knob casing [1] through the hole in the panel from the front.
- ▶ Screw the universal nut [2] onto the knob casing [1] from the rear and tighten a little.
- ▶ Use the marking to align the knob casing [1] vertically in the 12 o'clock position.
- ▶ Tighten the universal nut [2].
- ▶ Slot the knob ring [3] onto the knob casing [1] and align it to the 12 o'clock position.

6.7 PKA planning options

INFO With the PKA cooktop extractor, you have the option of configuring the airflow either to the left or the right to suit your requirements.

INFO The pre-fitted angled ducting piece or straight ducting piece (supplied) can feed the airflow either in a 90° angle to the rear or straight out to the side.

INFO If using the straight ducting piece, an additional EFD straight duct seal is required (not supplied).

- The cooktop extractor is supplied with a pre-fitted angled ducting piece going to the right.

6.7.1 Airflow straight to the side

INFO For straight airflow to the side, the installation must be rotated around 180°. This means the cover frame also needs to be rotated (see rotating the cover frame around 180°).

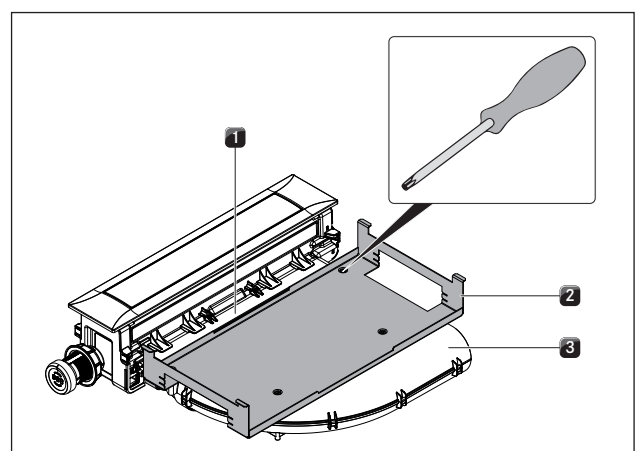

Fig. 6.24 Remove the holding plate

- [1] Ducting piece adapter
- [2] Holding plate
- [3] Bent ducting piece

- ▶ Undo the Torx screw (size 10) securing the holding plate [2] to the angled ducting piece [3].
- ▶ Undo the 2 Torx screws (size 10) securing the holding plate [2] to the ducting piece adapter [1].
- ▶ Remove the holding plate [2].

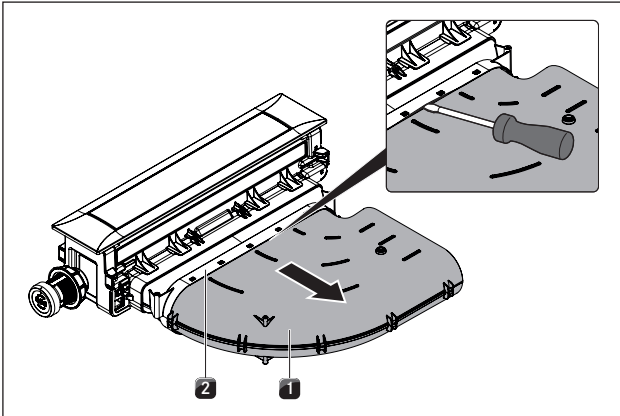

Fig. 6.25 Remove the angled ducting piece

- [1] Angled ducting piece
- [2] Ducting piece adapter

- ▶ Release the angled ducting piece [1] from the ducting piece adapter [2].
- ▶ To do this, carefully disconnect the plug connection using a flat screwdriver.
- ▶ Remove the angled ducting piece [1].
- ▶ If necessary, rotate the cover frame around 180° (see Rotating the cover frame around 180°).

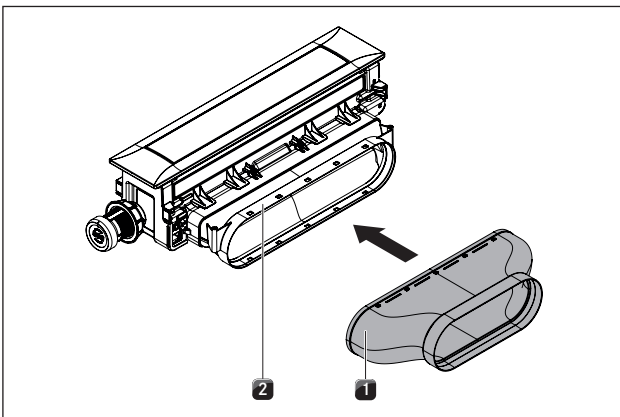

Fig. 6.26 Mounting the straight ducting piece

- [1] Straight ducting piece
- [2] Ducting piece adapter

- ▶ Push the straight ducting piece [1] onto the ducting piece adapter [2] until the fastening lugs click into place.
- ▶ Make sure that no air gap has formed between the components.
- ▶ Secure the holding plate to the ducting piece adapter [2] with just 2 screws.

6.7.2 Airflow to left (installation rotated around 180°)

INFO The PKA cooktop extractor can be fitted rotated around 180° so that the airflow is to the left.

Airflow to the left with angled ducting piece

- ▶ Dismount the holding plate and the angled ducting piece (see Airflow straight to the side).
- ▶ Rotate the cover frame around 180° (see Rotating the cover frame around 180°).

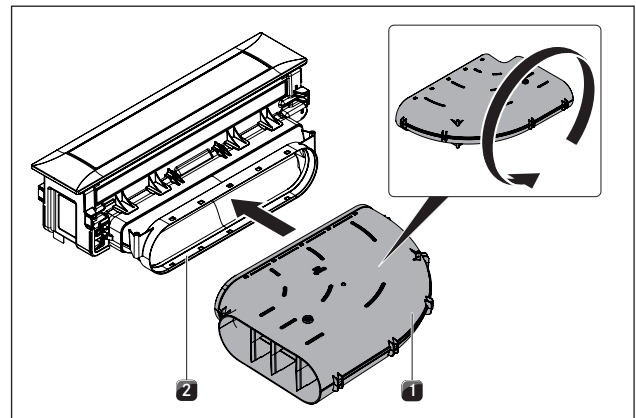

Fig. 6.27 Turn angled ducting piece

- [1] Angled ducting piece
- [2] Ducting piece adapter

- ▶ Turn the angled ducting piece [1].
- ▶ Push the rotated angled ducting piece [1] back onto the ducting piece adapter [2] until the fastening lugs click into place.

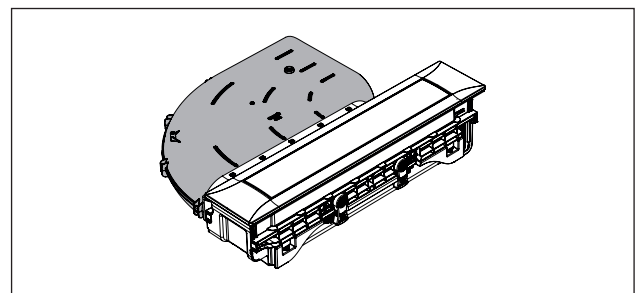

Fig. 6.28 Airflow to the left with angled ducting piece

- ▶ Make sure that no air gap has formed between the components.
- ▶ Secure the holding plate.

Rotate the cover frame about 180°.

INFO In order to correct the direction of the cover frame, it may need to be rotated around 180°.

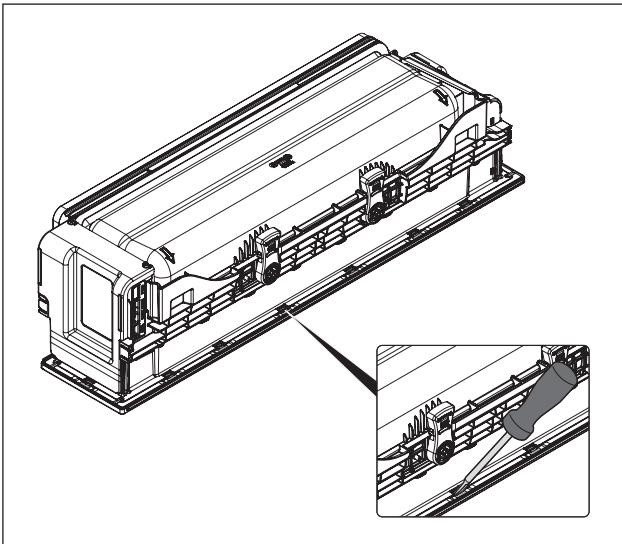

Fig. 6.29 Dismounting the cover frame

- ▶ Rotate the cooktop extractor and place it down carefully with the visible surface on a soft surface (e.g. a blanket).
- ▶ Carefully undo the holding clamps (18x) with a screwdriver.

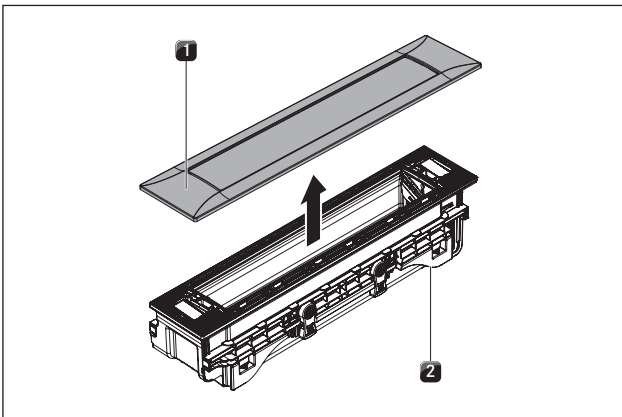

Fig. 6.30 Dismounting the cover frame

- [1] cover frame
[2] Cooktop extractor

- ▶ Rotate the cooktop extractor [2] and remove the cover frame [1].
- ▶ Rotate the cover frame [1] by 180°.
- ▶ Replace the cover frame [1] back on the cooktop extractor [2].
- ▶ Make sure that the holding clamps slot into place.

6.8 Installing the duct system

6.8.1 Preparing for installation

INFO The floor unit must not be supported on the plinth fan housing.

INFO For correct installation, the slide-in units of the base cabinet must be shortened depending on the installation situation.

INFO When fitting the seals, make sure it fits and forms an air-tight seal with the connection duct piece when compressed.

- ▶ Adjust the ducting parts to the height of the worktop.
- ▶ Saw out the necessary cut-outs for the ducting in the rear panel of the floor unit.

Preparing for installation of cooktop extractor PKA

- ▶ Depending on the installation situation, adjust the levelling feet on the floor unit as necessary.
- ▶ Prepare the plinth fan by attaching the sealing tape depending on the installation situation.
- ▶ Secure the sealing tape to the inlet nozzle.

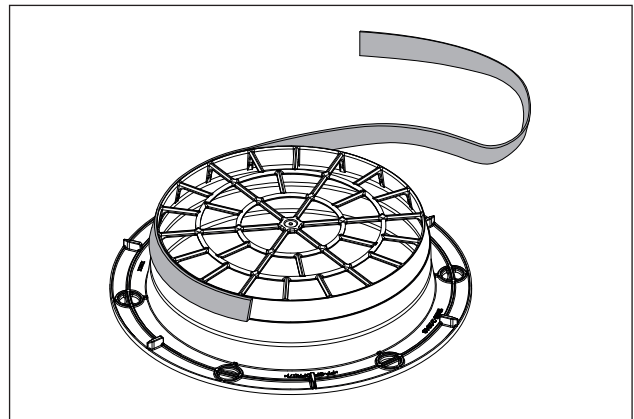

Fig. 6.31 Sealing tape position for installation with a round duct

- Depending on the required connection cross-section, you can vary the height at which the sealing tape is attached to the plinth fan inlet nozzle.

INFO If another universal fan module is to be used, it must also be prepared with sealing tape on the inlet nozzles as described here.

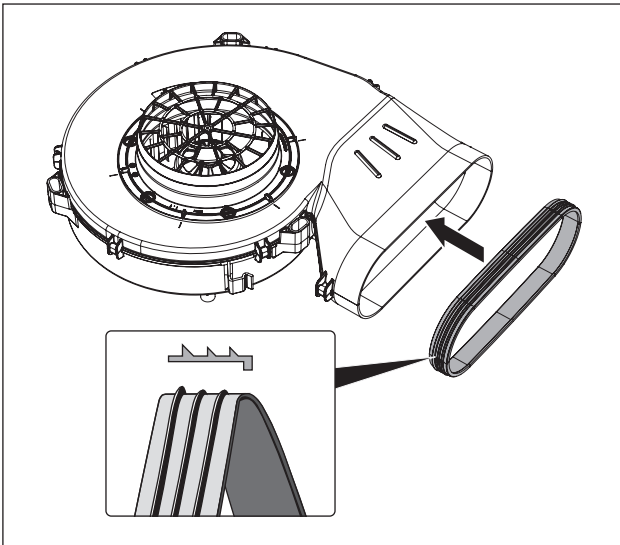

Fig. 6.32 Applying seal to the inlet nozzles of the plinth fan.

- ▶ Push the seal onto the outlet nozzles of the plinth fan. This means stretching the seal slightly.

6.8.2 Connect the duct system to the device.

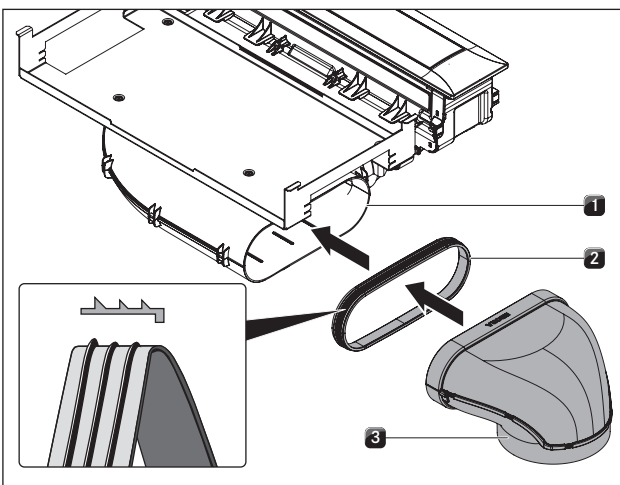

Fig. 6.33 Connecting to the duct system.

- [1] Output nozzles
- [2] Seal
- [3] Ducting piece

- ▶ Pull out the seal [2] on the connection fitting [1] of the device. This means stretching the seal [2] slightly.
- ▶ Push the duct piece [3] to be connected with the sleeve on the connection fitting [1] with the seal [2].
- ▶ Make sure the seal [2] does not move.

INFO When fitting the seal, make sure it fits and forms an air-tight seal with the connection duct piece when compressed.

6.8.3 Standard setup PKA

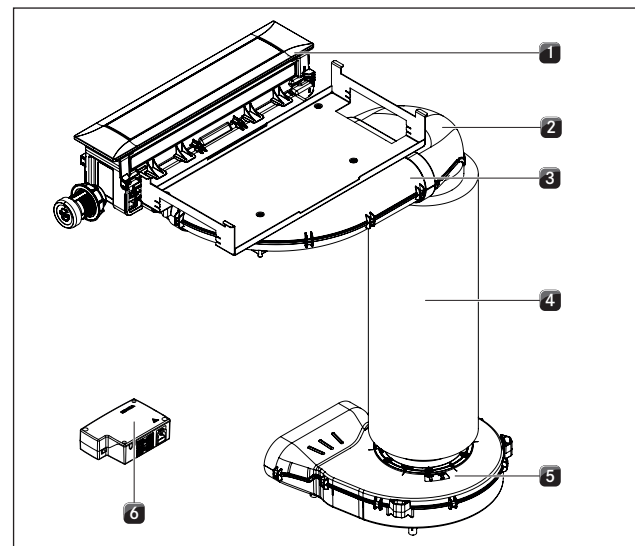

Fig. 6.34 Standard setup PKA

- [1] Cooktop extractor
- [2] 90° diverter
- [3] Bent ducting piece
- [4] Silencer
- [5] Universal plinth fan
- [6] Universal control unit

- ▶ Push the 90° diverter [2] onto the angled ducting piece [3].
- ▶ Position the plinth fan [5].
- To facilitate positioning, the inlet nozzle on the plinth fan can be removed. To do this, please see the assembly instructions for the ULS universal plinth fan.
- ▶ Connect the silencer [4] to the plinth fan [5].
- ▶ Connect the silencer [4] to the 90° diverter [2].
- There is also the option of gluing the connections between the ducting sections and the plinth fan with UDB sealing tape.

INFO Position the plinth fan and the universal control unit in such a way that they are easily accessible and removable for maintenance work.

- The maximum exhaust air duct length with a fan is 6 m.
- The minimum cross-section of the air ducts must be 176 cm², which equates to a round pipe with a diameter of 150 mm or the BORA Ecotube duct system.
- For the ducting, only use stable duct elements with smooth pipe interiors. Do not use flexible or fabric tubes.

6.8.4 Installing the additional fan

- ▶ Install the additional fan in the exhaust duct.
- ▶ Ensure that a minimum clearance of 3 m is maintained between the fan units.
- ▶ Only use BORA universal fans with your BORA cooktop extractor system.

6.9 Operating the cooktop extractor with a fireplace that depends on the air in the room

INFO The state and regional laws and regulations must be observed with regard to the exhaust duct design. A sufficient air supply must be ensured.

Fireplaces that depend on the air in the room (e.g. gas, oil, wood or coal-fired heaters, continuous-flow water heaters, instantaneous water heaters) draw in air from the room in which they are installed and release the exhaust fumes into the outside air via an exhaust system (e.g. chimney).

If the cooktop extractor is used in exhaust mode, it draws in air from the room in which it is installed as well as from neighbouring rooms. If there is insufficient air supply, low pressure will occur. Toxic gases could be drawn out of the chimney or extraction ducting and back into the room.

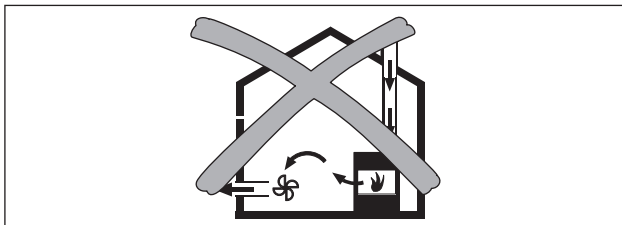

Fig. 6.35 Exhaust air installation – not permitted

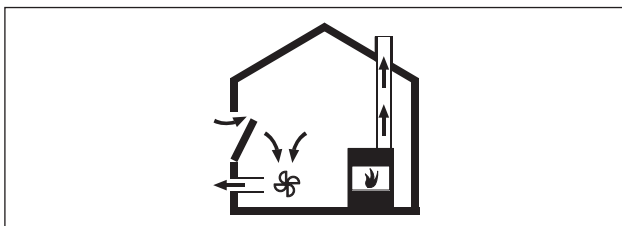

Fig. 6.36 Exhaust air installation – correct

- ▶ If simultaneously operating both a fireplace and the cooktop extractor in the same room, ensure that:
 - the maximum low pressure is 4 Pa (4×10^{-5} bar);
 - a safety device (e.g. window contact switch, low pressure warning device) is used to ensure that a sufficient supply of fresh air is guaranteed;
 - the exhaust air is not be ducted into a chimney that is used for exhaust gases of devices operated with gas or other combustibles;
 - the installation is checked and approved by an authorised certified engineer (e.g. heating engineer).

6.10 Connecting external switch contacts

INFO The Home In and Home Out communication connections must only be connected by a certified specialist. The specialist also assumes responsibility for the proper installation and commissioning.

When using Home In and Home Out, you will require the relevant documents for the external switch devices in order to ensure safe device connection and operation. The following switch contacts can be used:

Contact	Function	Connection
Home In	Cooktop extractor on/off connection for external switch contact (contact closed: cooktop extractor on)	24V DC 100 mA
Home Out	Electrically isolated contact for controlling external installations depending on the operating status of the cooktop extractor (cooktop extractor on: contact closed)	maximum 250 VAC / 30 VDC, 2,5A

Tab. 6.5 Switch contacts

INFO The Home In contact can be used for external safety devices (e.g. window contact switches). If the switch is open, the cooktop extractor is out of operation.

- ▶ Make sure that the universal control unit is disconnected from the power supply.

PKAS and PKASAB preparation

INFO To ensure that the surface of the device does not get scratched when the cooktop extractor system is rotated, a surface must be used that will protect the device (e.g. cardboard).

- ▶ Place a soft layer on the surface.
- ▶ Rotate the cooktop extractor system and place it with the top of the top side of the device on the soft layer.
- ▶ Undo the screws on the control unit on the bottom of your cooktop extractor system.
- ▶ Lift up the cover [1].

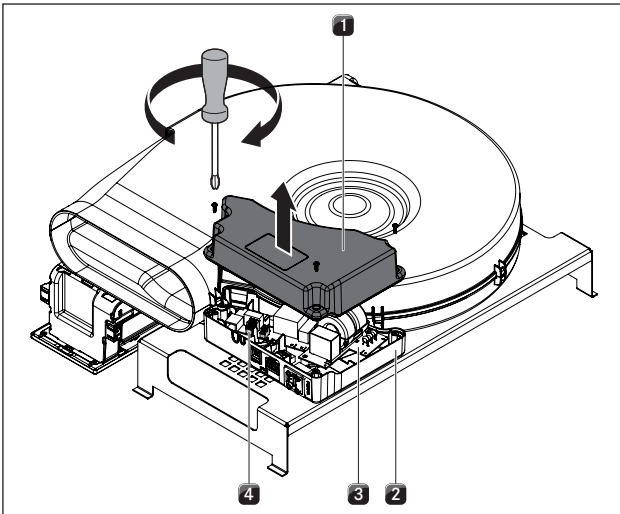

Fig. 6.37 Open the cover of the control unit

- [1] Cover
- [2] Housing
- [3] Electronic unit
- [4] Switch contact terminals

INFO The electronic unit [3] can contain residual charge. You must therefore be careful not to touch the exposed contacts on the electronic unit!

PKA preparation

- ▶ Remove the screws from the universal control unit.
- ▶ Lift up the cover [1].

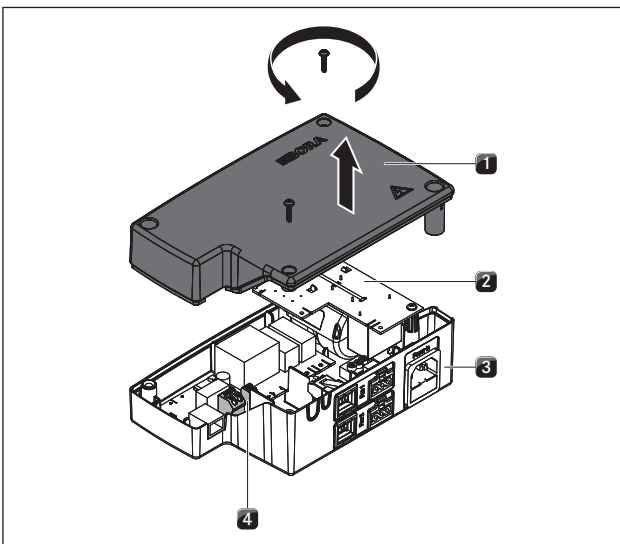

Fig. 6.38 Open the universal control unit's cover

- [1] Cover
- [2] Electronic unit
- [3] Base unit
- [4] Switch contact terminals

INFO The electronic unit [2] can contain residual charge. You must therefore be careful not to touch the exposed contacts on the electronic unit!

Preparing connection cables for external switching equipment

Use connection cables of the following types and manufacturers to connect external switchgear.

Contact	Connection cable	
Home In	H03VV-F	2 x 0.5 mm ²
Home Out	H03VVH2-F	2 x 0.75 mm ²

Tab. 6.6 Connection cable

INFO The connection cable is only intended for internal use in buildings, private households, kitchens or offices.

INFO The overall length of the connection cable for external switching equipment must not exceed 10 m!

For reasons of electromagnetic compatibility, all connection cables from external switch devices must be filtered with a ferrite sleeve. This is not included in the scope of delivery.

- ▶ Use the order code UFH (universal filter sleeve) to order the filter sleeve from your specialist supplier or contact BORA via the website at www.bora.com.

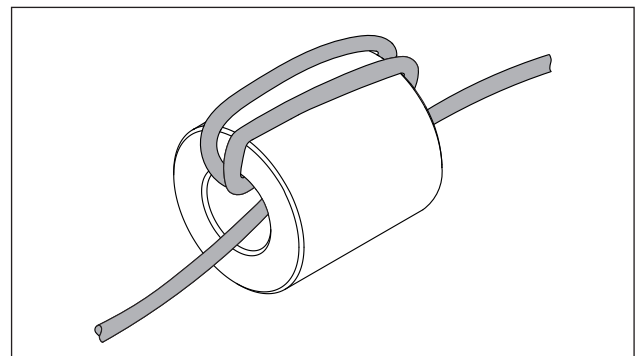

Fig. 6.39 Wrap the connection cable round the ferrite sleeve three times

- ▶ Wrap the connection cable around the ferrite sleeve 3 times to create the desired filter performance.
- ▶ Ensure that the cable end protrudes at least 120 mm from the sleeve.
- ▶ Prepare the connection cable in accordance with the prescribed stripping lengths.

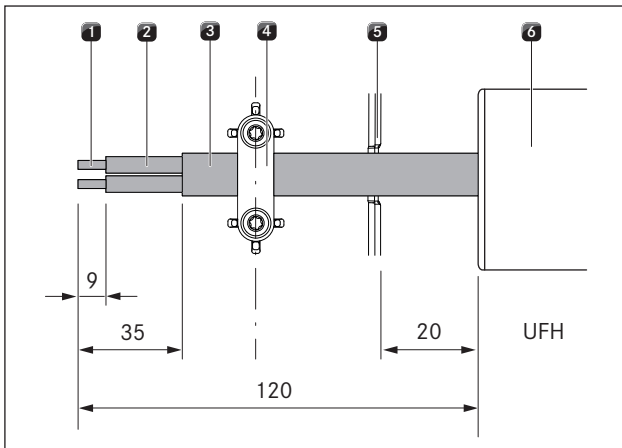

Fig. 6.40 Stripping lengths and installation position for connection cable

- [1] Stripped wire end
- [2] Insulated wire
- [3] Jacketed cable
- [4] Strain relief clamp
- [5] Cable feed snap-out element
- [6] Universal ferrite sleeve (UFH)

- Please adhere to the maximum stripping length of 9 mm on the stripped wire end [1].
- Please adhere to the maximum stripping length of 26 mm on the insulated wire [2].

Installing the external switch device

Depending on the type of switch device, connect the connection cables to either the Home In or the Home Out connection clamp.

- ▶ Adhere to the connection diagram when connecting Home In and Home Out.

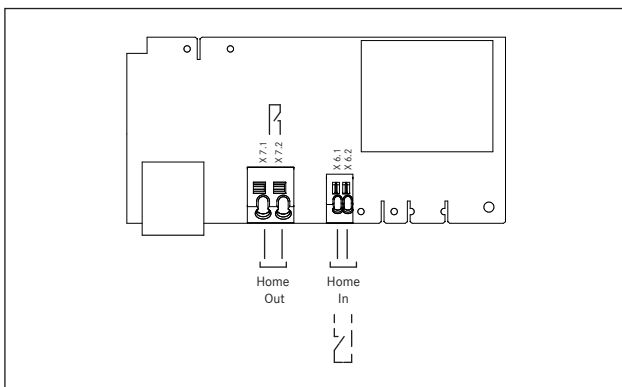

Fig. 6.41 Connection diagram for the external switch contacts

- ▶ Connect the cable for the relevant contact to the switch contact clamp in accordance with the relevant connection diagram (see fig. Connection diagram for the external switch contacts).
- In order to connect the Home In interface, the installed bridge must be removed.

INFO The Home In contact must be bridged if this is not used (bridged on delivery).

- For connections to the Home In connection clamp, no ferrules may be used.
- ▶ Clamp the connection cable in the strain relief clamp [4] in accordance with the wire cross section used.

INFO If external switching devices are connected both to the Home In and Home Out interfaces, both cables should be secured with the strain relief claim [4].

- ▶ Remove the relevant snap-out element [2] in the plastic housing of the universal control unit.

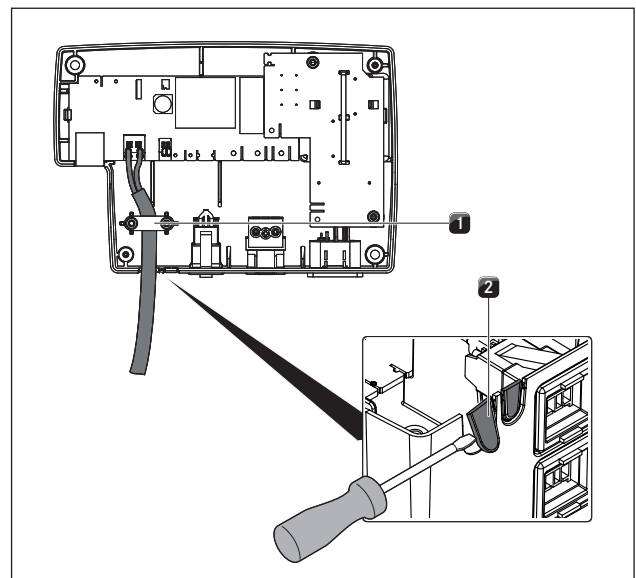

Fig. 6.42 Home Out contacts with strain relief

- [1] Strain relief clamp
- [2] Snap-out element for cable feed

- ▶ Check the correct installation, as well as the firm positioning of the connection cables.
- ▶ Close the cover on the universal control unit.
- ▶ Make sure that the cable is not damaged.
- ▶ Switch on the main switch/automatic circuit breaker.

6.11 Establishing communication and power connection

- ▶ Observe all safety and warning information (see the Safety section).
- ▶ Observe all national and regional laws and regulations as well as the supplementary regulations of the local utility companies.
- The plug for the power supply must be accessible following installation.
- If the power supply cable has been damaged this must be replaced.

6.11.1 Connecting the control knob

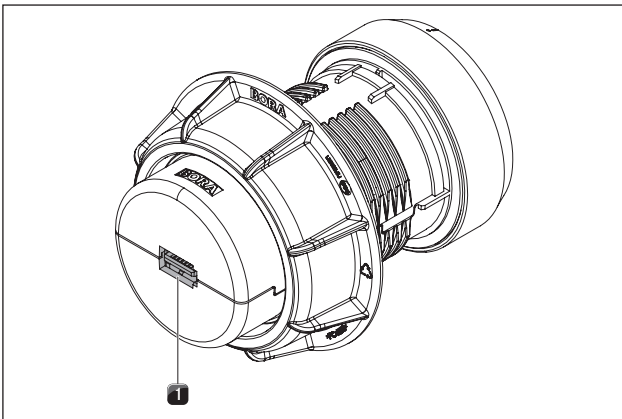

Fig. 6.43 Back of control knob with connection

[1] Control knob connection

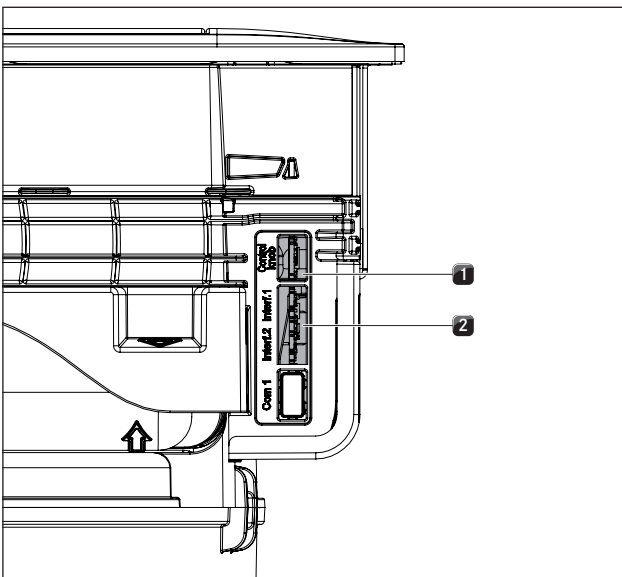

Fig. 6.44 Side connections on cooktop extractor

[1] Connection the control knob
[2] Connection for cooktops

- ▶ Connect the control knob connection to the side connection on the cooktop extractor [1].
- ▶ Use the ribbon cable provided.

6.11.2 PKAS and PKASAB connections

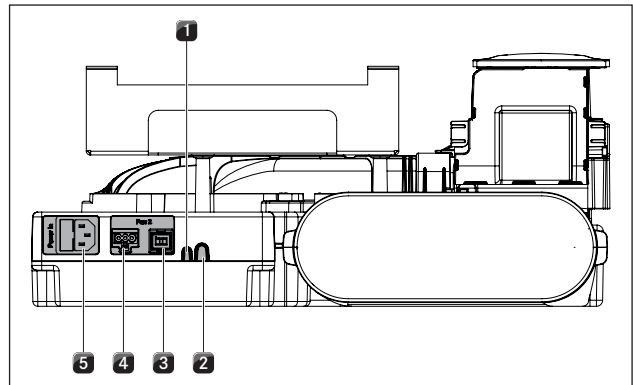

Fig. 6.45 PKAS and PKASAB rear connections

[1] Home In
[2] Home Out
[3] Control line for additional fan
[4] Mains connection cable for additional fan
[5] Power supply cable with microfuse

6.11.3 PKA connection

Connecting the universal control unit and fan to the cooktop extractor

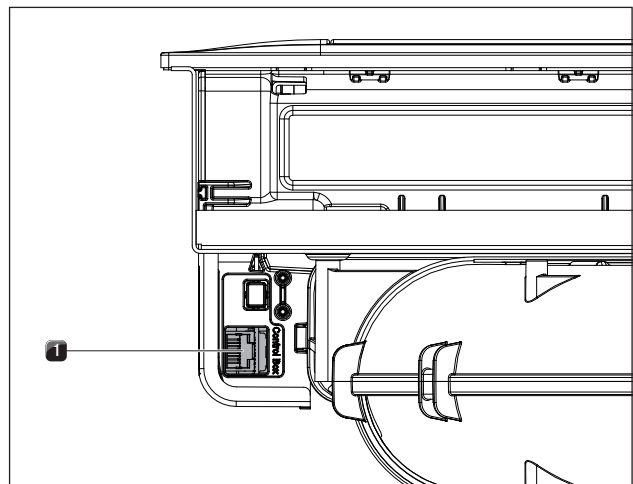

Fig. 6.46 Side connection for control unit on cooktop extractor PKA

[1] Control unit connection

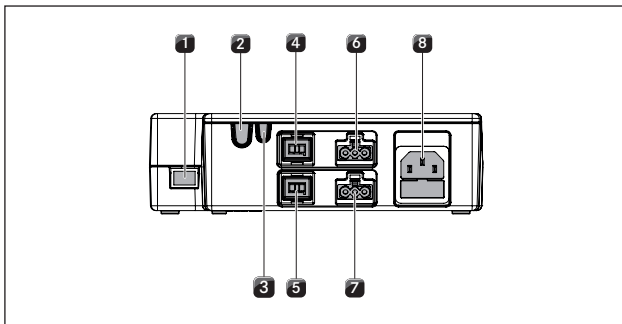

Fig. 6.47 Connections on the universal control unit

- [1] CAT 5 communication cable
- [2] Home Out
- [3] Home In
- [4] Fan 1 control line
- [5] Fan 2 control line
- [6] Fan 1 power supply cable
- [7] Fan 2 power supply cable
- [8] Power supply cable with microfuse

- ▶ Use the CAT 5 communication cable to connect the connection for the control unit on the cooktop extractor to the connection on the universal control unit [1].

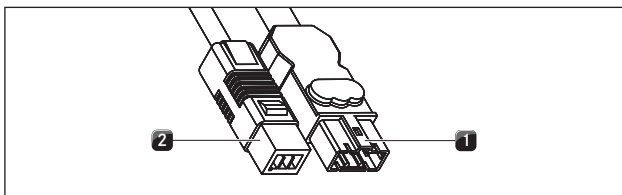

Fig. 6.48 Connection plug of the plinth fan

- [1] Connection plug of the plinth fan power supply cable
- [2] Connection plug of the plinth fan control line

- ▶ Connect the plinth fan's control line [2] to the universal control unit.
- ▶ Connect the plinth fan's power supply cable [1] to the universal control unit.

Release the power supply cable

To release the power supply cable for the fan [1] from the universal control unit [6] you need a small flat screwdriver.

- ▶ Disconnect the universal control unit's power supply cable from the power supply [8].
- ▶ Make sure that there is no power to the appliance.
- ▶ Use the flat screwdriver to loosen the lock on the fan power supply cable plug.
- ▶ To do this, insert the flat screwdriver into the gap in the socket.
- ▶ Press the lock down gently.
- ▶ Use the flat screwdriver to gently lever the plug of the power supply cable out of the universal control unit's socket.
- ▶ Now disconnect the power supply cable from the socket.

- ▶ Check the plug and the socket for damage.
- ▶ Do not use damaged components.
- ▶ Contact your BORA specialist supplier to replace any damaged components.

Connecting the additional fan

- ▶ Connect the fan control line [2] to the universal control unit [5].
- ▶ Connect the fan mains connection line [1] to the universal control unit [7].
- ▶ Check all the plug connections to ensure that they are secure.

6.11.4 Establishing the power connection

- ▶ Connect the mains connection line for the extraction system (PKAS, PKASAB) or the mains connection cable for the universal control unit (PKA) to the power supply.
- ▶ Put the cooktop extractor into operation (see the Operation section).
- ▶ Check that all the functions are working correctly.

6.12 Configuration menu

Once installation is complete, you must configure certain basic settings for your cooktop extractor (see also the supplementary information sheet on initial commissioning).

6.12.1 Accessing the configuration menu

- ▶ Turn the knob ring from the 12 o'clock position to the 11 o'clock position.
- A0 appears in the control knob display.
- ▶ Now press the touch surface for 5 seconds.
- This accesses the configuration menu and □ is shown on the control knob display.

6.12.2 Select menu option

► Turn the knob ring to select the menu option you want. The following menu options are available:

Display	Menu option	
Ⓒ0	Volume of warning beep	
Ⓒ1	Select operating mode (demo mode)	
Ⓒ2	Speed of cover flap motors	
Ⓒ3	Selection of filter unit	
Ⓒ4	Exhaust air and/or recirculation (summer or winter mode)	No current function
Ⓒ5	Operation with/without wall sleeve	
Ⓒ6	Manual operation of cover flap motors	
Ⓒ7	Switchover of PWM values for PKA/PKAS, PKASAB fan	for BORA Service Technicians only

Tab. 6.7 Menu options in the configuration menu

- Touch the touch surface on the control knob again for 1 second to confirm the menu you want.
- The sub-menu is accessed and the display switches to a three-character combination (e.g. Ⓒ23).

INFO In the three-character combination shown, the right-hand figure shows the value saved in the system.

Setting the volume of the warning beep

Once you have confirmed menu option Ⓒ0, you can set the volume of the warning beep.

Setting	Warning beep volume
Ⓒ00	100% (max. volume) Factory setting
Ⓒ01	10% (min. volume)
Ⓒ02	20%
Ⓒ03	30%
Ⓒ04	40%
Ⓒ05	50%
Ⓒ06	60%
Ⓒ07	70%
Ⓒ08	80%
Ⓒ09	90%

Tab. 6.8 Warning beep volume

Select mode

When you have confirmed menu option Ⓒ1, you can select the operating mode.

Setting	Mode
Ⓒ10	Normal operating mode Factory setting
Ⓒ11	Demo mode

Tab. 6.9 Operating modes

INFO In demo mode, all the control knob functions are active and the electric cover flap and the fan work. Demo mode is used, for example, for exhibitions.

Adjust the speed of the cover flap motor

You can adjust the speed of the cover flap motor under menu option Ⓒ2.

Setting	Speed of cover flap
Ⓒ20	100% (fastest)
Ⓒ21	10% (slowest)
Ⓒ22	20%
Ⓒ23	30%
Ⓒ24	40%
Ⓒ25	50%
Ⓒ26	60% Factory setting
Ⓒ27	70%
Ⓒ28	80%
Ⓒ29	90%

Tab. 6.10 Speed of cover flap

Selecting the filter unit

You can select the filter unit installed under menu option Ⓒ3.

INFO Selecting correctly is key to ensure the filter timer is set to the service life of the activated charcoal filter (recirculation mode only).

INFO In the event of a power cut, the last setting saved is shown for 2 minutes.

Setting	Filter system	Service life
Ⓒ30	Exhaust air	No filter timer required
Ⓒ31	ULB1	200 h
Ⓒ32	ULB3 (factory setting)	400 h
Ⓒ33	ULBF	300 h

Tab. 6.11 Selecting the filter unit

Operation with/without wall sleeve

In the $\overline{C5}$ menu option, you can select whether the extraction system is operated with or without the BORA 3box (UEBF) wall sleeve.

Setting	Mode
$\overline{C50}$	Operation with wall sleeve
$\overline{C51}$	Operation without wall sleeve

Tab. 6.12 Operation with or without wall sleeve

Manual operation of cover flap motors

You can open or close the cover flap manually in the menu option $\overline{C6}$.

Setting	Function
$\overline{C60}$	Exit sub-menu
$\overline{C61}$	Opening the cover flap
$\overline{C62}$	Closing the cover flap

Tab. 6.13 Manual operation of cover flap motors

6.12.3 Changing the setting

- ▶ Turn the knob ring clockwise to increase the value.
- ▶ Turn the knob ring anticlockwise to decrease the value.
- ▶ Press the touch surface on the control knob again for 1 second to confirm the new setting. The value is saved and a beep sounds. The previously selected menu option is shown again on the control knob display.

6.12.4 Exiting configuration menu

- ▶ Twist the knob ring until the display shows \overline{C} .
- ▶ Now press the touch surface on the control knob again for 1 second to exit the configuration menu.
- ▶ Twist the knob ring to the 12 o'clock position. \overline{C} appears on the display for 10 seconds. The display then goes out with a beep.

INFO If no settings are changed in a menu or sub-menu option for 2 minutes, the configuration menu is closed automatically.

6.13 Handover to user

Once installation is complete:

- ▶ Explain the main functions to the user.
- ▶ Explain all safety-related aspects of operation and handling to the user.
- ▶ Provide the user with the accessories and the operating and installation instructions for safe storage.

7 Operation

- ▶ Observe all safety and warning information during operation (see the Safety section).

INFO The cooktop extractor must only be operated with BORA cooktops.

INFO The cooktop extractor can only be operated if the grease filter components are installed.

7.1 General operating instructions

The cooktop extractor is controlled using the control knob. There are 9 power levels, 1 power setting and various functions available:

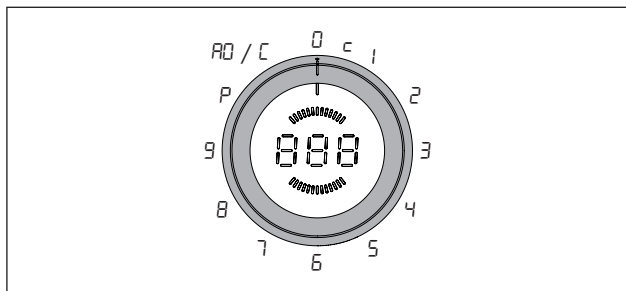

Fig. 7.1 Knob ring assignment

Knob ring position	Function
0	Fan off
c	Cleaning position
1 - 9	Power levels
P	Power setting
AD	Automatic cooktop extractor function
C	Configuration menu (see the Installation section)

Tab. 7.1 Knob ring positions

7.2 Operating the cooktop extractor

Recommendations for efficient vapour extraction

- ▶ Always use a lid on pots that are particularly high. This ensures effective vapour extraction. It also reduces power consumption.
- ▶ Only operate the cooktop extractor at the minimum power level required for effective vapour extraction. This enables you to improve the performance of the odour filters in recirculation mode.
- ▶ Only operate the hob at the minimum power level required for cooking. This reduces the cooking vapours and the power consumption.
- ▶ Avoid strong drafts.

7.2.1 Switching on the cooktop extractor

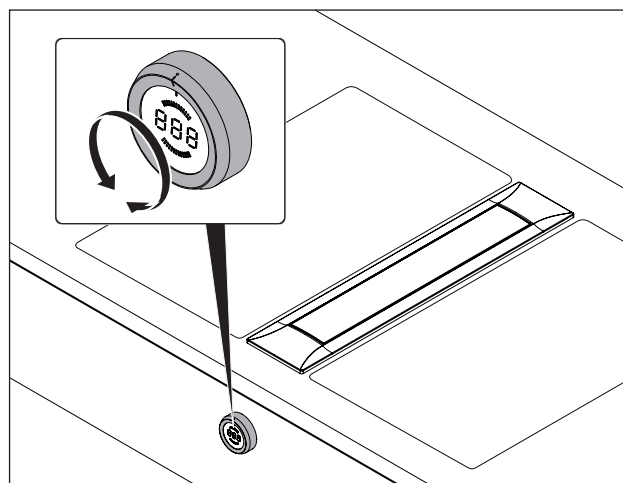

Fig. 7.2 Switching on the cooktop extractor

- ▶ Turn the knob ring from the 12 o'clock position to the power level you want. The knob clicks in at the different levels.
- ▶ Avoid undefined interim positions.

INFO If the control knob ring is turned to an undefined interim setting, the most recently selected power level is automatically activated.

Adjusting the power level

- ▶ Turn the knob ring to the desired power level.
- The power level selected is shown in the power display on the control knob.

Set power setting

- ▶ Twist the knob ring to the 10 o'clock position.
- The cooktop extractor will run for a maximum of 9 minutes on the power setting. P is displayed on the power display on the control knob.

7.2.2 Automatic cooktop extractor function

INFO The extraction power is generally adjusted 30 seconds after the power level is set on the cooktop.

- ▶ Twist the knob ring to the 11 o'clock position.
- If now power level is yet set on one of the cooktops connected, AD is shown on the control knob display.
- If, for example, one of the cooktops connected is set to power level 7, then the display changes to A7 and the extraction power is automatically adjusted with a 30 second delay.
- If all the cooking zones connected are switched off or temporarily stopped, the automatic after-run starts.

Deactivate automatic cooktop extractor function:

- ▶ turn the knob ring to a power level, the power setting or the 12 o'clock position.

7.2.3 Switching off the cooktop extractor

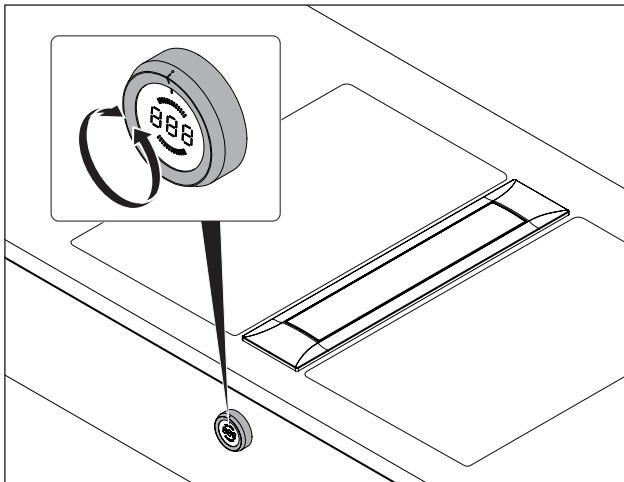

Fig. 7.3 Switching off the cooktop extractor

- ▶ Twist the knob ring to the 12 o'clock position. The knob ring slots into this position and the automatic after-run starts.

7.2.4 Automatic after-run

- Once the cooktop extractor is switched off, the automatic after-run starts. \bar{n} appears in the control knob display.
- The cooktop extractor switches off automatically after 20 minutes and the cover flap closes.

Deactivate automatic after-run early.

- ▶ Press the touch surface of the control knob for a second. An acoustic signal can be heard and the display switches to \bar{d} .
- The cover flap closes and the display goes out after 10 seconds.

7.2.5 Childproofing feature

The cooktop extractor has a childproofing feature to prevent accidental switching on.

Activating the childproofing feature

INFO The childproofing feature can only be activated if the knob ring is in the 12 o'clock position and there are no active functions.

- ▶ Press the touch surface of the control knob for 5 seconds.
- An acoustic signal can be heard and the display on the control knob switches to \bar{L} . After 10 seconds, another acoustic signal sounds and the display goes out. The childproofing feature is activated.

Permanently deactivating the childproofing feature

INFO The childproofing feature can only be permanently deactivated if the knob ring is in the 12 o'clock position.

- ▶ Press the touch surface of the control knob for 5 seconds.
- An acoustic signal can be heard and the display on the control knob switches to \bar{L} . After 10 seconds, another acoustic signal sounds and the display goes out. The childproofing feature is deactivated.

Deactivating the childproofing feature for a cooking session

- ▶ Turn the knob ring from the 12 o'clock position to a power level.
- \bar{L} appears in the control knob display.
- ▶ Press the touch surface of the control knob for 5 seconds.
- An acoustic signal can be heard and the control knob display shows the power level selected.
- The childproofing feature is only deactivated for this cooking session and you can set the power level you want.
- The childproofing feature is reactivated next time you switch on.

7.2.6 Crush protection

The electrical cover flap on the cooktop extractor has crush protection.

- If the cover flap is blocked while it is opening or closing, the movement is stopped automatically.
- The cover flap moves back to its starting position.
- \bar{End} is displayed on the control knob.
- ▶ Remove the foreign body which is in the way.
- ▶ Press the touch surface for 1 second.
- The cover flap is working again.
- If the cover flap is blocked three times in succession while automatically opening or closing, the appliance will be automatically disabled for 5 minutes.
- ▶ To re-activate the appliance after 5 minutes, touch the touch-operated area for 1 second.

7.3 Note the filter service function

If a flashing \bar{F} is shown on the control knob display after switching on the cooktop extractor, the service life of the activated charcoal filter is up (for recirculation only) and the grease filter needs thorough cleaning.

Exiting the filter service display and setting a power level

- ▶ Press the touch surface of the control knob for a second.
- The control knob display switches to the power level selected. The fan motor starts up at the power level selected.

Changing the filter

- ▶ Switch off the cooktop extractor.
- ▶ Observe all the information provided in the Cleaning section.
- ▶ Replace the activated charcoal filter.
- ▶ Clean the grease filter.

Resetting the filter service display

If the activated charcoal filter has been replaced and the grease filter has been cleaned, it will be necessary to reset the filter service display.

- ▶ Twist the control knob to the 12 o'clock position.
- ▶ Within 10 seconds, press the touch surface of the control knob for 5 seconds.
- The display switches to  and the filter service display is reset.

8 Cleaning and maintenance

- ▶ Observe all safety and warning information (see the Safety section).

INFO Clean the stainless steel surfaces in the polishing direction only.

- Regular cleaning and maintenance ensures the longevity of the product and optimal function.
- ▶ Adhere to the following cleaning and maintenance cycles:

Component	Cleaning cycle
Cooktop extractor interior and surface	After cooking very greasy dishes; at least once a week
Cover flap, grease filter and filter tray	After cooking very greasy dishes; at least once a week
Maintenance tray	as required (when the activated charcoal filter is replaced at the latest for recirculation mode)
Activated charcoal filter (with recirculation only)	Replace if odours have built up or the service life has expired (see Filter service display)
Knob ring/Knob housing	Immediately after every soiling

Tab. 8.1 Cleaning cycles

8.1 Cleaning agents

INFO Due to the use of aggressive cleaning agents and abrasion caused by the pot bases the surface will become damaged and dark stains will occur.

- ▶ Never use steam cleaners, abrasive sponges, scouring pads or chemically aggressive cleaning agents (e.g. oven cleaner spray).
- ▶ Make sure that the cleaning agent does not contain any sand, soda, acids, lyes or chloride.

8.2 Cleaning the cooktop extractor

Grease particles and limescale residues from cooking vapours can settle on the surface and in the extraction system.

- ▶ Clean the components of the cooktop extractor in accordance with the cleaning intervals.
- ▶ Remove the cover flap, grease filter and filter tray prior to cleaning.
- ▶ Clean the surfaces using a soft, damp cloth, detergent or a mild window cleaning agent.
- ▶ Soften dried on dirt using a damp cloth (do not scrape it off!).

8.2.1 Cleaning position for cover flap

INFO The cleaning position is between the 12 o'clock position and the 1 o'clock position.

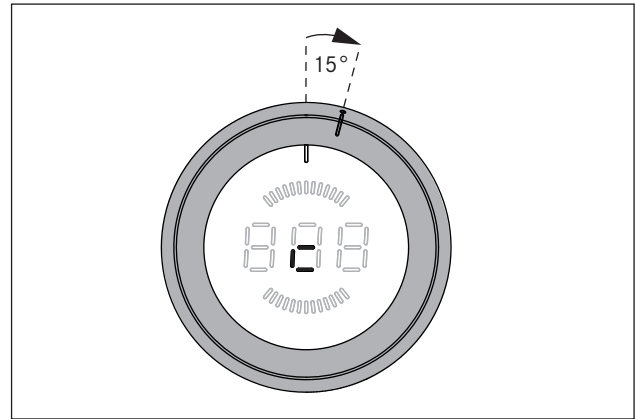

Fig. 8.1 Cleaning position

- ▶ Make sure that the cooktop extractor is switched off (see the Operation section).
- ▶ Turn the selector ring approximately 15° clockwise from the 12 o'clock position until it lightly engages.
 - The display shows c and the cover flap opens.
 - The fan motor does not run or switches itself off if it was running.

8.2.2 Removing the cover flap, the grease filter and the filter tray

INFO The grease filter components can only be removed if the cover flap is in the cleaning position.

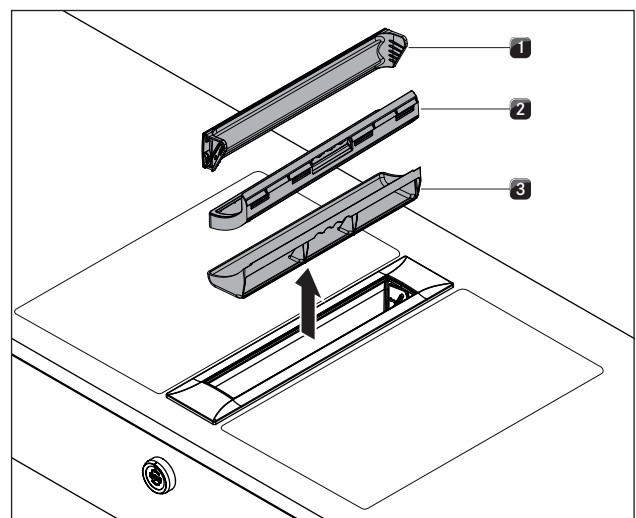

Fig. 8.2 Removing the grease filter components

- [1] Cover flap
- [2] Grease filter
- [3] Filter tray

- ▶ Lift the cover flap [1] off upwards.
- ▶ Reach into the opening in the cooktop extractor and remove the grease filter [2] and the filter tray [3].

8.2.3 Fitting the cover flap, the grease filter and the filter tray

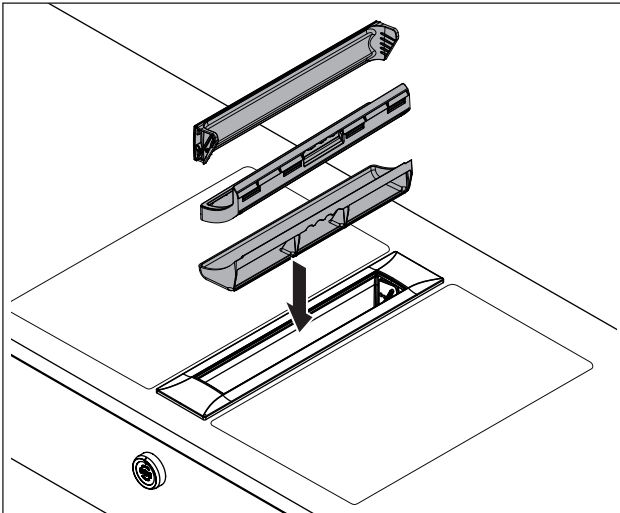

Fig. 8.3 Fitting the components

- ▶ Fit the filter tray into the exhaust opening.
- ▶ Insert the grease filter into the exhaust opening.
- ▶ Make sure the grease filter sits correctly in the opening in the casing.

Inserting the cover flap:

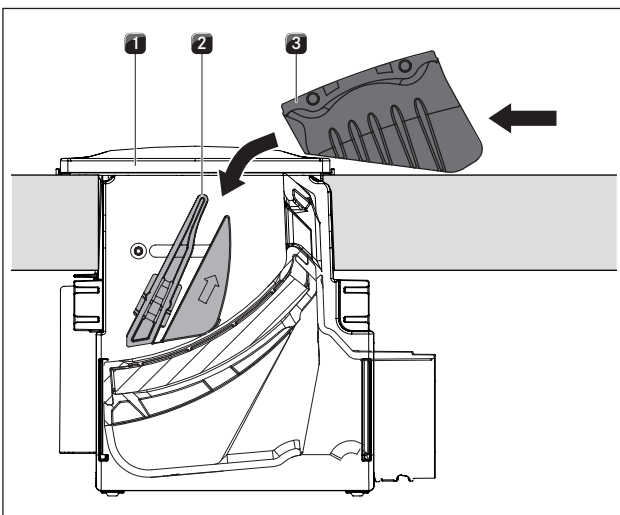

Fig. 8.4 Inserting the cover flap

- [1] Exhaust opening
- [2] Guided tour
- [3] Cover flap

- ▶ Place the cover flap [3] on the side next to the exhaust opening [1].
- ▶ Allow the cover flap [3] to slide vertically into the guide [2].
- ▶ Gently press the narrow side of the cover flap [3] from the top until you feel it slot into place.
- ▶ Make sure the cover flap [3] is correctly fitted.

INFO If the cover flap is not fully in the slot after fitting, it cannot be closed properly.

INFO If the grease filter or the cover flap have not been properly fitted, error message E0 12 or E0 13 appears on the control knob display (see Troubleshooting section).

8.2.4 Removing the maintenance tray

INFO The maintenance tray cannot be removed in the following installation scenarios. Single installation, adjacent 2nd extractor, adjacent wok cooktop.

INFO To remove the maintenance tray, the grease filter and the filter tray must first be removed.

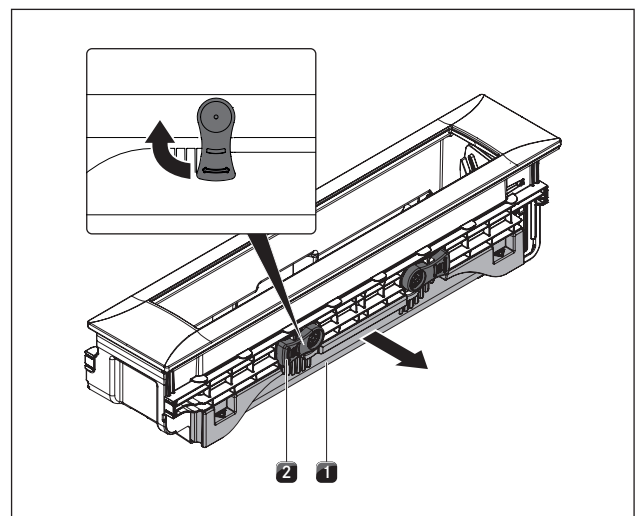

Fig. 8.5 Removing the maintenance tray

- [1] Maintenance tray
- [2] Locking

- ▶ To unlock the maintenance tray [1], twist the two locking levers [2] 90° outwards.
- ▶ Remove the maintenance tray [1] from the cooktop extractor.

8.2.5 Fitting the maintenance tray

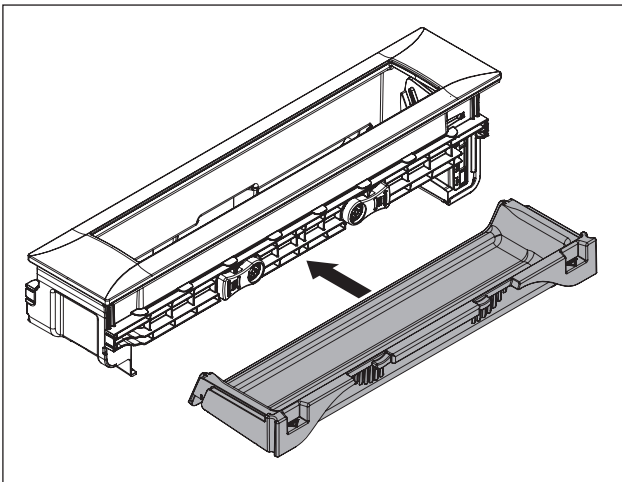

Fig. 8.6 Fitting the maintenance tray

- ▶ Push the maintenance tray into the cooktop extractor.
- ▶ Twist the two locking levers [2] downwards to lock the maintenance tray [1] in place.

8.2.6 Cleaning of the components

The cover flap, grease filter, filter tray and maintenance tray can be cleaned manually or in a dishwasher.

Manual cleaning

- ▶ Use a cleaner and degreaser in one.
- ▶ Rinse the components in hot water.
- ▶ Clean the components with a soft brush.
- ▶ Rinse the components well after cleaning.

Cleaning in the dishwasher

- ▶ If cleaning in the dishwasher, the temperature should not exceed 65 °C.
- The grease filter absorbs the greasy particles from cooking vapours.
- If you can no longer get the grease filter properly clean, it needs to be replaced.

8.2.7 Finish cleaning the cooktop extractor

- ▶ Twist the knob ring to the 12 o'clock position.
- This exits cleaning mode and the cover flap closes.

8.3 Cleaning the control knobs

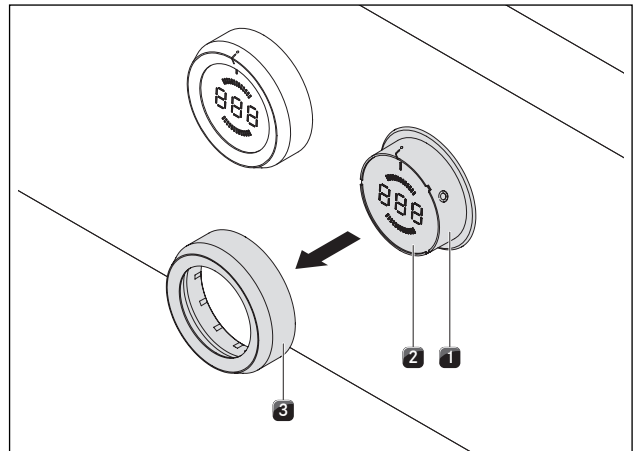

Fig. 8.7 Pull out the knob ring

- [1] Knob casing
- [2] Touch surface
- [3] knob ring

- ▶ Make sure that the cooktop extractor is switched off (see the Operation section).

8.3.1 Cleaning the knob ring

The knob ring can only be cleaned by hand.

- ▶ Remove the knob ring from the knob housing.
- ▶ Use a cleaner and degreaser in one.
- ▶ Rinse the knob ring in hot water.
- ▶ Clean the knob ring with a soft brush.
- ▶ Rinse the knob ring well after cleaning.
- ▶ Dry the knob ring carefully.
- ▶ Place the dry knob ring back on the knob housing.
- ▶ Make sure it is positioned correctly (0 position).
- ▶ If necessary, twist the knob ring to the 12 o'clock position (= 0 position).

8.3.2 Cleaning the touch surface and the knob housing

- ▶ Pull off the knob ring.
- ▶ Clean the touch surface and the knob housing with a soft, damp cloth.
- ▶ Dry the touch surface and the knob housing carefully.
- ▶ Place the knob ring back on the knob housing.

INFO If the knob ring has not been fitted correctly, a segment rotating clockwise is displayed in the central control knob display 

8.4 Replacing the activated charcoal filter

In recirculation mode, an additional activated charcoal filter is used. The activated charcoal filter absorbs cooking odours. The activated charcoal filter is installed on the plinth fan or the duct system.

INFO Regularly replace the activated charcoal filter. The service life can be found in the operating instructions for the relevant activated charcoal filter.

INFO You can obtain activated charcoal filters from your specialist supplier or by contacting BORA via the website at www.bora.com.

- A description of how to replace the activated charcoal filter can be found in its operating instructions.
- ▶ Reset the filter service display (see the Operation section).

9 Troubleshooting

► Observe all safety and warning information (see the Safety section).

Operating situation	Cause	Remedy
Cooktop extractor will not switch on	Knob ring missing	Place knob ring on the control knob
	The fuse or automatic circuit breaker of the electrical wiring system in the apartment and/or house is defective.	Replace the fuse. Switch the automatic circuit breaker back on
	The fuse or the automatic circuit breaker trips multiple times.	Contact BORA Service Team
	The power supply is disconnected.	Have a specialist electrician inspect the power supply
Fan motor does not start	The microfuse in the cooling device plug connector for the control unit is defective.	Replace the fuse (type: T 3,15A/250V)
	Cover flap not fitted or not fitted correctly	Fit cover flap correctly
	Grease filter not fitted or not fitted correctly	Fit grease filter correctly
Odours form when operating the new cooktop extractor	Fan motor faulty	Contact BORA Service Team
	Normal for brand new devices	Odours stop forming after a few operating hours
The central control knob display shows a segment turning clockwise 	Knob ring not in the 0 position after fitting	Turn the control knob to the 12 o'clock position (= 0 position)
Control knob display <i>L</i>	The childproofing feature is activated	Switch off the childproofing feature (see the Operation section).
Control knob display <i>r'</i>	Continuous operation (30 s) of the control knob or control knob dirty	Release or clean the control knob
Control knob display <i>E</i>	Home-in contact is interrupted	Check cable or bridge for home-in contact For example, window opened in exhaust mode.
Control knob display <i>F</i>	Activated charcoal filter service life expired	Replace the activated charcoal filter, clean the stainless steel grease filter if necessary, reset the filter timer (see Cleaning or Operation section)
Control knob display <i>Errd</i>	Foreign body blocking cover flap	Remove the foreign body
	Cover flap not properly slotted into the guide	Press the cover flap gently from above on the narrow side until you hear it slot into place
	End switch faulty or out of place	Contact BORA Service Team
	Power failure when the cover flap is opened or closed	Turn the control knob to position "0" and tap to confirm. The cover flap will close.
Control knob display <i>EO03</i>	Electrical connection between touch surface and knob ring (min. 3-5 seconds).	Remove and clean the knob ring. Wipe off any residual water on the touch surface
Control knob display <i>EO11</i>	Grease filter not fitted or not fitted correctly	Fit grease filter correctly
	Filter sensor faulty	Contact BORA Service Team
Control knob display <i>EO12</i> and <i>EO13</i>	Cover flap not fitted or not fitted correctly	Fit cover flap correctly
	Cover flap sensor faulty	Contact BORA Service Team
Control knob display <i>EO19</i>	Error evaluating the touch surface	Twist control knob to "0" position Contact BORA Service Team
	The extraction performance of the cooktop extractor has decreased.	The stainless steel grease filter is heavily soiled Clean or replace the stainless steel grease filter
Cover flap not fully open/closed	The activated charcoal filter is heavily soiled (recirculation only)	Replacing the activated charcoal filter
	There is a foreign body in the air guiding housing (e.g. cleaning cloth).	Remove the foreign body
	The fan is defective or a duct connection has become loose	Contact BORA Service Team
	The movement process was interrupted by an interruption in the electricity supply	Manual operation of the cover flap up to the end-position (p. Chap. Assembly Table 6.13)

Tab. 9.1 Resolving a fault

- After troubleshooting, turn the knob ring to the 12 o'clock position (0 position).
- In all other cases, contact the BORA Service Team (see section 'Warranty, technical service and spare parts) and enter the error number displayed and the device type.

10 Decommissioning, disassembly and disposal

- ▶ Observe all safety and warning information (see the Safety section).
- ▶ Follow the enclosed manufacturer's information.

10.1 Decommissioning

Decommissioning is understood as final shutdown and disassembly. Following decommissioning, the device can either be installed into other units, sold on privately or disposed of.

INFO Electricity and gas connections may only be disconnected by qualified specialists.

- ▶ To decommission, switch the device off (see Operation section)
- ▶ Disconnect the device from the power supply.

10.2 Disassembly

For removal, the device must be accessible for disassembly and disconnected from the power supply.

- ▶ Undo the mounting brackets.
- ▶ Remove the silicone joints.
- ▶ Disconnect the device from the extractor duct.
- ▶ Remove the device from the worktop by lifting it upwards.
- ▶ Remove any other accessories.
- ▶ Dispose of the old device and any contaminated accessories as described under "Environmentally-friendly disposal".

10.3 Environmentally-friendly disposal

Disposal of transport packaging

INFO The packaging protects the device from damage in transport. The packaging materials have been selected from environmental and disposal perspectives and are therefore recyclable.

Returning the packaging to the materials cycle saves resources and reduces waste volumes. Your specialist supplier will take the packaging back.

- ▶ Give the packaging to your specialist supplier or
- ▶ Dispose of the packaging properly in line with local regulations.

Disposal of old appliance



Electrical devices marked with this label may not be disposed of in domestic waste at the end of their service life. They must be disposed of at a collection point for the recycling of old electrical or electronic devices. You can find information from your city or district council.

Many electrical and electronic devices still contain valuable materials. But they also contain damaging materials which were necessary for them to function properly and safely. These can damage human health or the environment if disposed of improperly or incorrectly handled.

- ▶ Never put your old appliance in domestic waste.
- ▶ Take the old appliance to a regional collection point for return and recycling electrical and electronic components and other materials.

11 Warranty, technical service, spare parts, accessories

- Observe all safety and warning information (see the Safety chapter).

11.1 BORA manufacturer's warranty

BORA provides its end customers with a 2-year manufacturer's warranty for its products. The end customer is entitled to this warranty in addition to the statutory claims for defects against the sellers of our products.

The manufacturer's warranty applies to all BORA products sold by authorised BORA dealers with the European Union, with the exception of products labelled by BORA as Universal products or accessories.

The manufacturer's warranty starts as soon as the BORA product is handed over to the end customer by an authorised BORA dealer and is valid for 2 years. By registering on www.bora.com/registration the end customer has the possibility of extending the manufacturer's warranty.

The manufacturer's warranty requires expert (in accordance with the valid BORA ventilation handbook and operating instructions at the time of installation) installation of the BORA products by an authorised BORA dealer. During use, the end customer is to adhere to the specifications and instructions in the operating manual. In order to file a warranty claim, the end customer is to notify their dealer or BORA of the fault and must present the receipt. Alternatively, the end customer can provide proof of purchase by registering on www.bora.com. BORA guarantees that all BORA products are free from material and product defects. The defect must exist prior to delivery of the product to the end customer. In the event that a warranty claim is filed, the warranty shall not commence anew.

BORA will correct defects in BORA products at its own discretion by repairing or replacing the product. All costs for the correction of defects under the manufacturer's warranty shall be assumed by BORA.

Expressly not covered by the BORA manufacturer's warranty are:

- BORA products that were not sold by authorised BORA dealers
- Damage caused by non-adherence to the operating instructions (including product care and cleaning) This represents improper use.
- Damage caused by normal use, e.g. traces of usage on the cooktop

- Damage caused by external influences (such as transport damage, ingress of condensation, damage caused by the elements such as a lightning strike)
- Damage caused by repairs or attempts to repair not made by BORA or persons authorised by BORA
- Damage to the glass ceramic
- Voltage fluctuations
- Secondary damage or claims for damages beyond the defect
- Damage to plastic parts

Legal claims, particularly statutory claims for defects or product liability are not limited by the warranty.

If a defect is not covered by the manufacturer's warranty, the end customer can employ the services of the BORA technical service, however, they must cover the costs themselves.

The laws of the Federal Republic of Germany apply to these warranty conditions.

You can contact us by:

- Telephone: +49 800 7890 0987 Monday to Thursday from 08:00-18:00 and Friday from 08:00-17:00
- Email: info@bora.com

11.1.1 Warranty extension

You can extend the guarantee by registering at www.bora.com/registration.

11.2 Service

BORA Service:

see reverse side of operating and assembly instructions



- In the case of faults you cannot fix yourself, contact your BORA specialist supplier or the BORA Service Team.

The BORA Service Team will require the type designation and serial number of your device (FD number).

Both values are indicated on the rate plate in the warranty insert and the underside of the device.

11.3 Spare parts

- Only use original spare parts for repairs.
- Repairs may only be carried out by the BORA Service Team.

INFO Spare parts can be obtained from your BORA dealer, the BORA online service website at www.bora.com/service or by calling the service number provided.

11.4 Accessories

- BORA Pro Stainless steel grease filter PKA1FF
- BORA Pro Cover flap PKA1VK
- BORA Pro Cover flap All Black PKA1VKAB
- BORA Pro Filter tray PKA1FW
- BORA Power supply cable Type I UNLI (AUS)
- BORA Power supply cable Type J UNLJ (CH)
- BORA Power supply cable Type G UNLG (GB-IE)
- BORA Pro knob ring PB1KR
- BORA Pro knob ring All Black PB1KRAB
- BORA window contact switch UFKS

Special accessory for recirculation systems:

- BORA air purification box flexible ULBF
- BORA air cleaning box Ecotube ULB1
- BORA activated charcoal filter set ULBAS for ULB3

Germany:

BORA Lüftungstechnik GmbH
Rosenheimer Str. 33
83064 Raubling
Germany
T +49 (0) 8035 / 9840-0
F +49 (0) 8035 / 9840-300
info@bora.com
www.bora.com

Austria:

BORA Vertriebs GmbH & Co KG
Innstraße 1
6342 Niederndorf
Austria
T +43 (0) 5373 / 62250-0
F +43 (0) 5373 / 62250-90
mail@bora.com
www.bora.com

Europe:

BORA Holding GmbH
Innstraße 1
6342 Niederndorf
Austria
T +43 (0) 5373 / 62250-0
F +43 (0) 5373 / 62250-90
mail@bora.com
www.bora.com

Australia - New Zealand:

BORA APAC Pty Ltd
100 Victoria Road
Drummoyne NSW 2047
Australia
T +61 2 9719 2350
F +61 2 8076 3514
info@boraapac.com.au
www.bora-australia.com.au

