

**EN** Operating and assembly instructions BHAS (BHA, BHU)

BORA Basic Hyper-glass-ceramic-cooktop with cooktop  
extractor – exhaust/recirculation

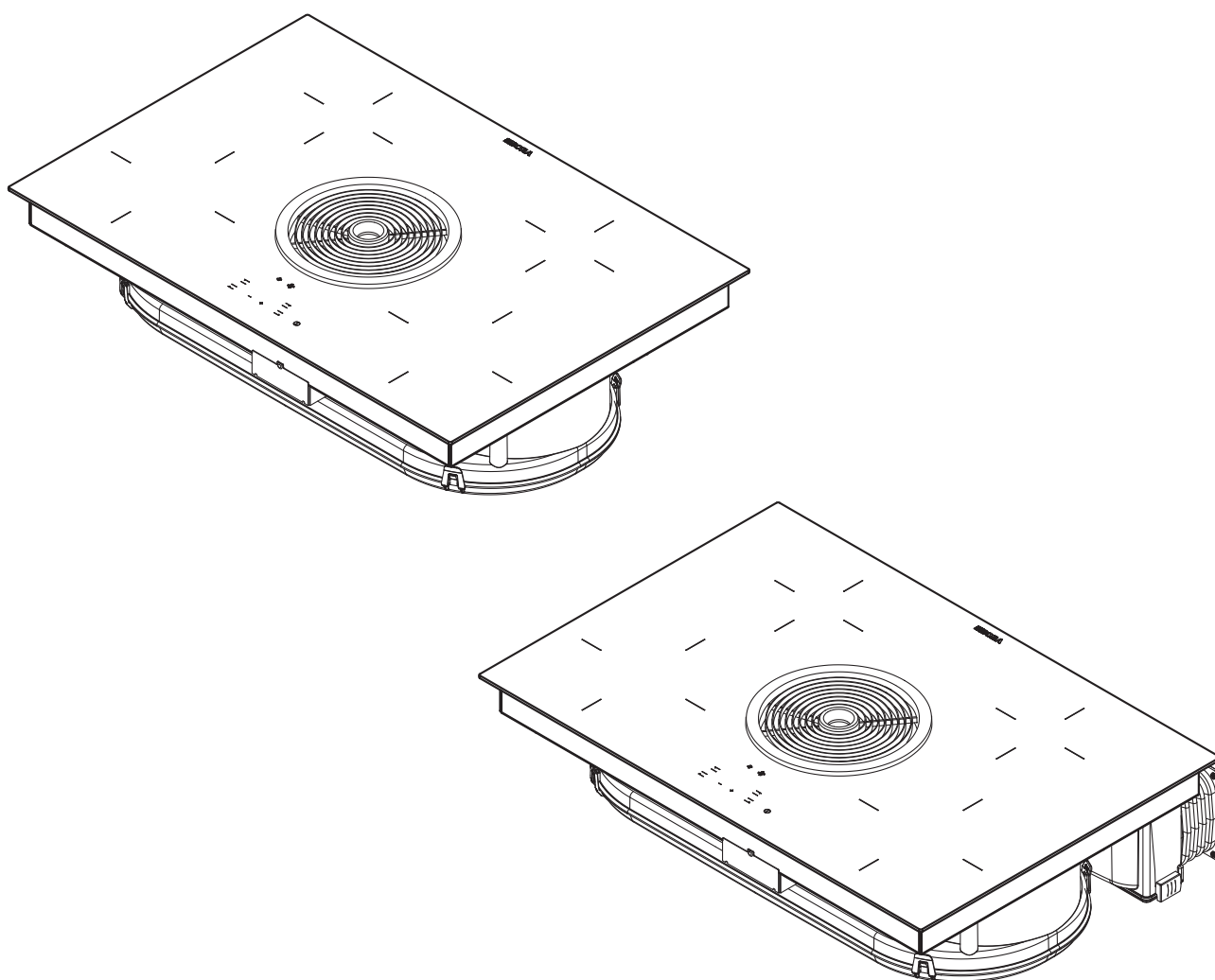

**BHASUMEN-003**

**Operating and installation instructions:**

Original

Translation

**Manufacturer**

**BORA Vertriebs GmbH & Co KG**

Innstraße 1  
6342 Niederndorf  
Austria

Contact

T +43 (0) 5373 / 62250-0  
mail@bora.com  
www.bora.com

The distribution and duplication of this document, as well as the use and disclosure of its contents are prohibited unless expressly authorised.

These operating and installation instructions have been drawn up with the greatest of care. But it cannot be ruled out that subsequent technical modifications have not yet been incorporated or the relevant content has not yet been adapted. Please accept our apologies in this eventuality. An updated version can be requested from the BORA Service Team. Subject to printing errors and mistakes.

© BORA Vertriebs GmbH & Co KG

All rights reserved.

# Table of Contents

<b>1</b>	<b>General information</b>	<b>4</b>	<b>7</b>	<b>Operation</b>	<b>30</b>
1.1	Target group.....	4	7.1	Switch on/off the cooktop and cooking zone .....	30
1.2	Validity of the operating and installation instructions...	4	7.1.1	Switching on the cooking zone .....	30
1.3	Other applicable documents .....	4	7.1.2	Adjusting the power level .....	30
1.4	Presentation of information.....	5	7.1.3	Changing the power level .....	30
			7.1.4	Switching on the power setting.....	30
<b>2</b>	<b>Safety</b>	<b>6</b>	7.1.5	Switching the power setting off early.....	30
2.1	General safety instructions.....	6	7.1.6	Switching off the cooking zone .....	30
2.2	Safety instructions – operation .....	7	7.1.7	Pay attention to the residual heat display.....	30
2.3	Safety instructions – installation .....	9	7.1.8	Using the automatic pre-cook valve.....	30
2.4	Safety instructions – disassembly and disposal .....	11	7.1.9	Using the timer function.....	31
2.5	Safety instructions – spare parts .....	11	7.1.10	Activating/deactivating the child safety lock .....	32
2.6	Intended use .....	11	7.2	Operating the cooktop extractor .....	32
			7.2.1	Switching on the cooktop extractor .....	32
<b>3</b>	<b>Technical data</b>	<b>12</b>	7.2.2	Setting the fan level .....	32
<b>4</b>	<b>Energy label</b>	<b>14</b>	7.2.3	Switching on the delayed automatic after-run.....	33
<b>5</b>	<b>Device description</b>	<b>15</b>	7.3	Pay attention to the filter service display.....	33
5.1	Structure .....	15	7.4	Saving energy.....	33
5.2	Operating panel and operating principle.....	16	<b>8</b>	<b>Cleaning and maintenance</b>	<b>34</b>
5.3	How the cooking zone works .....	17	8.1	Cleaning agents .....	34
5.3.1	Power levels.....	17	8.2	Maintaining the cooktop.....	34
5.3.2	power setting .....	17	8.3	Cleaning the cooktop.....	34
5.3.3	Timer functions.....	17	8.4	Cleaning the cooktop extractor.....	35
5.3.4	Suitable cookware .....	17	8.4.1	Removing the air inlet nozzle and stainless steel grease filter .....	35
5.4	How the cooktop extractor works.....	17	8.4.2	Cleaning the air inlet nozzle and stainless steel grease filter .....	35
5.4.1	power setting .....	17	8.4.3	Installing stainless steel grease filter and air inlet nozzle .....	35
5.4.2	Automatic after-run.....	17	8.5	Cleaning the air guiding housing .....	35
5.4.3	Filter service display .....	17	8.5.1	Opening the air guiding housing.....	35
5.5	Safety devices.....	18	8.5.2	Closing the air guiding housing .....	36
5.5.1	Residual heat display .....	18	8.6	Replacing the activated charcoal filter.....	36
5.5.2	Safety shut-down .....	18	<b>9</b>	<b>Troubleshooting</b>	<b>38</b>
5.5.3	Overheating protection .....	18	<b>10</b>	<b>Decommissioning, disassembly and disposal</b>	<b>39</b>
5.5.4	Automatic switch-off if the button is pressed and held .....	18	10.1	Decommissioning.....	39
5.5.5	Child safety lock.....	18	10.2	Disassembly .....	39
			10.3	Environmentally-friendly disposal .....	39
<b>6</b>	<b>Assembly</b>	<b>19</b>	<b>11</b>	<b>Warranty, technical service, spare parts, accessories</b>	<b>40</b>
6.1	Checking the scope of delivery .....	19	11.1	Warranty.....	40
6.2	Tool and aids.....	19	11.2	Service.....	40
6.3	Assembly instructions.....	19	11.3	Replacement parts.....	40
6.3.1	Safety distances.....	19	11.4	Accessories.....	40
6.3.2	Work surface and kitchen units.....	19	<b>12</b>	<b>Notes</b>	<b>41</b>
6.3.3	Cooktop air intake .....	20			
6.4	Dimensions of cut-out for cooktop.....	20			
6.5	Attaching the sealing tape.....	21			
6.6	Installing the air recirculation version (BHU).....	21			
6.7	Installing exhaust air duct variant (BHA) .....	24			
6.7.1	Using the cooktop extractor with a fireplace which does not depend on room air .....	24			
6.8	Establishing the power connection .....	28			
6.9	Handover to user .....	29			

# 1 General information

## 1.1 Target group

These operating and installation instructions apply for the following target groups:

Target group	Requirements
User	The appliance can be used by children aged 8 and above as well as people with reduced physical, sensory or mental capacities or a lack of experience and/or knowledge if they are supervised or have been instructed how to safely use the appliance and understand the resultant risks. Children must be supervised. All safety and warning information and the handling instructions in the installation instructions must be complied with.
Ambitious DIYers	Ambitious DIYers can independently conduct all joinery and installation work providing they possess the necessary skills and expertise. They must never independently establish electricity and gas connections.
Installation specialists	Installation specialists are authorised to conduct all joinery and installation work in line with existing regulations. The electricity and gas connections must be certified by a certified engineer for the applicable trade prior to commissioning.
Electricians	The electrical connection may only be established by a certified engineer. He/she also assumes responsibility for the proper electrical installation and commissioning.
Gas specialists	The gas connection may only be established by certified engineers. They also assume responsibility for proper installation and commissioning of the gas system.

Tab. 1.1 Target groups

---

**INFO** BORA Holding GmbH, BORA Vertriebs GmbH & Co KG, BORA APAC Pty Ltd and BORA Lüftungstechnik GmbH - hereinafter referred to as BORA - do not assume any liability for damage arising from non-adherence to these documents and from improper assembly! The electricity and gas connections must be made by a qualified specialist. Installation must comply with the valid standards, regulations and laws. All safety and warning information and the operating and installation instructions must be complied with.

---

## 1.2 Validity of the operating and installation instructions

These instructions apply to several device versions. It is therefore possible that some of the features described do not apply to your appliance.

## 1.3 Other applicable documents

These operating and installation instructions are valid in conjunction with other documents, which must be adhered to.

Please be sure to adhere to all documents that form part of the scope of delivery.

---

**INFO** BORA accepts no liability for damage caused by failure to comply with these documents!

---

### Directives

This device meets the following EU/EC directives:

2014/30/EU EMC Directive

2014/35/EU Low Voltage Directive

2009/125/EC Ecodesign Directive

2010/30/EU Energy Consumption Label Directive

2011/65/EU RoHS Directive

2012/19/EU WEEE Directive

## 1.4 Presentation of information

To make working with these instructions quick and easy, consistent formatting, numbering, symbols, safety instructions, terms and abbreviations are used throughout.

**Handling instructions are marked with an arrow.**

- ▶ Always carry out handling instructions in the sequence shown.

**Bullet points are indicated by a square bullet point at the edge of the line.**

- Bullet point 1
- Bullet point 2

---

**INFO** Information points out specific points you must always comply with.

---

### Safety and warning information

The safety and warning information in these instructions are highlighted with symbols and signal words.

Safety and warning information is structured as follows:

---

#### WARNING SYMBOL AND SIGNAL WORD!



**Type and source of the danger**

Consequences of non-compliance

- ▶ Measures to minimise risk
- 

The following applies:

- The warning symbol draws attention to the danger.
- The signal word indicates the severity of the risk.

Warning sign	Signal word	Hazard
	<b>Danger</b>	Indicates an imminent hazardous situation which could lead to death or serious injury if ignored.
	<b>Warning</b>	Indicates an imminent hazardous situation which could lead to death or serious injury if ignored.
	<b>Caution</b>	Indicates a potentially hazardous situation which could lead to slight or minor injuries if ignored.
–	<b>Caution</b>	Indicates a situation which could result in material damage if ignored.

---

Tab. 1.2 Meaning of warning symbols and signal words

## 2 Safety

### 2.1 General safety instructions

**INFO** The appliance complies with the stipulated safety requirements. The user is responsible for appliance cleaning and maintenance as well as its safe use. Improper use can lead to personal injury and damage to property.

- The operating and installation instructions contain important information about installation and operation. These enable you to protect yourself against injuries and prevent damage to the appliance. Contact details for further information as well as application and usage questions can be found on the back of these operating and installation instructions.
- The term device applies to cooktops, cooktop extractors and cooktops with cooktops extractors.
  - ▶ Read the operating and installation instructions fully before using the appliance for the first time.
  - ▶ Always store the operating and installation instructions within easy reach so that they can be accessed if required.
  - ▶ Pass the operating and installation instructions to the next owner if you sell the appliance.
  - ▶ Conduct all work extremely attentively and conscientiously.
  - ▶ Check the appliance for visible damage when unpacking it.
  - ▶ Do not connect a damaged appliance.
  - ▶ Only use the appliance once all installation activities are complete. This is the only way to ensure safe operation.
  - ▶ Make sure that hot hobs are not touched.
  - ▶ Avoid boiling over.
  - ▶ Pay attention to the residual heat display.
  - ▶ Switch the device off after use.
  - ▶ Keep pets away from the appliance.

#### CAUTION!

#### Risk of injury from falling device components!

Falling device components such as pan supports, control elements, covers, grease filters, etc. can cause injuries.

- ▶ Place device components safely near the devices after you remove them.
- ▶ Make sure that none of the device components you have removed could fall.

### Recirculation mode

**INFO** When cooking, additional moisture is released into the ambient air.

**INFO** In recirculation mode, only a slight amount of moisture is removed from the cooking vapour.

- ▶ When using recirculation mode, ensure a sufficient supply of fresh air, e.g. by opening a window.
- ▶ Ensure a normal and comfortable room climate (humidity of 45–60%), e.g. by opening natural ventilation openings or using domestic ventilation systems.
- ▶ After every use in recirculation mode, switch the cooktop extractor to a low level for about 20 minutes or activate the automatic after-run function.

### Households with children and people with special needs

- ▶ The appliance can be used by children aged 8 and above as well as people with reduced physical, sensory or mental capacities or a lack of experience and/or knowledge if they are supervised or have been instructed how to safely use the appliance and understand the resultant risks.
- ▶ Supervise children in the vicinity of the appliance.
- ▶ Children must not play with the appliance.
- Use the childproofing feature to prevent children accidentally switching the cooktop on or changing the settings.

- ▶ Do not store any items that could be of interest to children in storage spaces above or behind the appliance. Children will otherwise be encouraged to climb on the appliance.
- ▶ Keep children and other people away from hot hobs.

### Unauthorised modifications

Unauthorised modifications can cause the appliance to pose risks.

- ▶ Do not conduct any modifications to the appliance.

### Cleaning and maintenance

The device must be cleaned regularly. Dirt can lead to damage or the buildup of odours. Remove any dirt immediately.

- Cleaning and maintenance work must not be carried out by children unless they are supervised at all times.
- ▶ Do not use steam cleaners. The steam can cause a short-circuit on live parts and cause damage to property (see Cleaning and maintenance section).
- ▶ Do not put hot cookware near the control panel so as not to damage the electronics underneath.
- ▶ Make sure no water penetrates inside the device when cleaning. Only use a slightly damp cloth. Never spray water on the device. Water ingress can cause damage!
- ▶ Where possible, clean the cooktop after every cooking session.
- ▶ Only clean the cooktop when it has cooled down.
- ▶ For cleaning, only use non-abrasive detergents to avoid scratching or wearing the surface.
- ▶ Make sure the base of the cookware and the cooking zone are clean and dry.
- ▶ Always lift the cookware (do not pull) to avoid scratching or wearing the surface.

- ▶ Do not place hot cookware on the air inlet nozzle of the cooktop extractor.
- ▶ Make sure that hot cookware does not come into contact with the edge of the air inlet nozzle.

## 2.2 Safety instructions – operation

### Cooktop



**DANGER!**  
**Unsupervised cooktops are a fire risk!**

Oil and fat can heat up and catch fire quickly.

- ▶ Never leave hot oil or fat unattended.
- ▶ Never attempt to extinguish burning oil or fat with water.
- ▶ Stifle the fire using a lid, for example.



**DANGER!**  
**Risk of explosion caused by flammable liquids!**

Flammable liquids in the vicinity of the cooktop can explode and cause serious injury.

- ▶ Do not place any flammable liquids in the vicinity of the cooktop.



**DANGER!**  
**Risk of electric shock!**

Chips, cracks or breaks in the glass ceramic panel can expose or damage the electronics underneath. This can lead to an electric shock.

- ▶ If the glass ceramic panel gets chipped, broken or cracked, switch the cooktop off immediately.
- ▶ Securely disconnect the appliance from the mains using LS switches, fuses, automatic circuit breakers or contactors.



**WARNING!****Risk of burns from hot cooktop!**

The cooktop and its exposed areas get hot during use. Once the cooking zone is switched off, it takes a little while to cool down below 60 °C. Touching hot surfaces can cause serious burns.

- ▶ Never touch the cooktop when it is hot.
- ▶ Keep children away from the cooktop when it is hot or ensure they are supervised at all times.

**WARNING!****Leaving items on the cooking surface is a fire risk!**

The cooktop and its touchable parts are hot when the cooking zone is switched on and during the cooling phase. Objects on the cooktop can get hot and catch fire.

- ▶ Do not place any items on the cooktop.

**WARNING!****Risk of burns from hot items!**

The cooktop and its touchable parts are hot during both operation and the cooling phase. Items placed on the cooktop heat up very quickly and can cause severe burns. This particularly applies to metal items (e.g. knives, forks, spoons, lids or cooktop extractor covers).

- ▶ Do not place any items on the cooktop.
- ▶ Please use suitable tools (pot holders, oven gloves).

**WARNING!****Risk of burns from hot cookware!**

Handles projecting over the edge are enticing for children to grab.

- ▶ Do not turn pot and pan handles so they stick out beyond the work surface.
- ▶ Make sure that children cannot pull hot pots and pans over.
- ▶ A special stove guard for children (available from specialist suppliers) reduces the risk.

**WARNING!****Risk of getting burnt!**

Liquid between the cooking zone and the pan base can evaporate and cause burns.

- ▶ Make sure that the cooking zone and the pan base are always dry.

**CAUTION!****Damage from hard and pointed objects!**

Hard and pointed objects can damage the glass ceramic panel of the cooktop!

- ▶ Do not use the surface of the cooktop as a worktop.
- ▶ Do not use hard and pointed objects when working on the cooktop.

**CAUTION!****Damage from sugary and salty foods!**

Sugary and salty foods and juices can damage the hot cooking zone.

- ▶ Make sure sugary and salty foods or juices do not get onto the cooking zone while it is hot.
- ▶ Remove sugary and salty foods and juices from the hot cooking zone.

**CAUTION!****Escaping hot liquids!**

Unattended pans can boil over allowing hot liquids to escape.

- ▶ Always keep an eye on pans while cooking.
- ▶ Short cooking sessions must be constantly monitored.

**CAUTION!****Damage from objects on the cooktop!**

Objects such as pan lids on the cooktop can damage the glass ceramics.

- ▶ Do not leave objects on the hot cooktop.



## Cooktop extractor



### **DANGER!**

#### **Risk of smoke inhalation!**

Using a fireplace that depends on the air in the room produces combustion gases.

If the cooktop extractor is used in conjunction with a fireplace that depends on the air in the room, toxic combustion gases (carbon monoxide) can be extracted from the chimney or outlet duct into the living area.

- ▶ Make sure that there is always a sufficient air supply.



### **DANGER!**

#### **Fire risk from flambéing!**

While the cooktop extractor is working, it sucks up grease from cooking. Flambéing food can cause the grease to catch fire.

- ▶ Clean the cooktop extractor regularly.
- ▶ Never work with a naked flame while the cooktop extractor is running.



### **DANGER!**

#### **Fire risk from fat deposits!**

If the stainless steel grease filter is not cleaned regularly, this can lead to increased levels of grease in it. This increases the fire risk.

- ▶ Clean and replace the filter at regular intervals.



### **CAUTION!**

#### **Touchable parts may become hot!**

The cooktop extractor and its touchable parts are hot when the cooking zone is switched on and during the cooling phase.

- ▶ Do not place any items on the cooktop.
- ▶ Please use suitable tools (pot holders, oven gloves).



### **WARNING!**

#### **There is a risk of injury when opening the lower cover on the housing!**

There is a risk of injury if the fan wheel turns.

- ▶ Switch the cooktop extractor and the cooktop off.
- ▶ Switch off the fuse.

### **CAUTION!**

#### **Damage caused by objects or paper suctioned in!**

Small and light items, such as cleaning cloths made from material or paper, can be suctioned into the cooktop extractor. This can damage the fan or impair the exhaust performance.

- ▶ Do not store any items or paper on the cooktop extractor.

### **CAUTION!**

#### **Damage caused by grease and dirt deposits!**

Grease and dirt deposits can stop the cooktop extractor from functioning properly.

- ▶ Never use the cooktop extractor without a stainless steel grease filter.

## 2.3 Safety instructions – installation

The device must only be installed and assembled by trained specialists who are familiar with and comply with the standard national regulations and supplementary regulations of the local utility companies.

Work on electrical components must be conducted by trained electrical personnel.

The electrical safety of the appliance is only guaranteed if it is connected to a protective conductor system that has been installed in line with regulations. Ensure that this basic safety precaution is met.

## Cooktop



### **DANGER!**

#### **Risk of electric shock!**

Incorrect connection of the device to the mains voltage could cause electric shocks.

- ▶ Make sure that the device is firmly connected to the mains voltage.
- ▶ Make sure the device is connected to a properly installed earth conductor system.
- ▶ Make sure a system is installed which allows disconnection from the network with a contact opening width of at least 3 mm across all poles (circuit breaker, fuses, automatic circuit breakers, contactors).



### **DANGER!**

#### **Risk of electric shock!**

If the mains connection cable comes into contact with hot hobs, it could get damaged. A damaged mains connection cable can cause a (deadly) electric shock.

- ▶ Make sure that the mains connection cable cannot come into contact with hot hobs.
- ▶ Make sure that the connection cable is not squashed or damaged.



### **CAUTION!**

#### **Lifting heavy loads can cause back injuries!**

If not correctly handled, removing and installing the device can cause injuries to the limbs or torso.

- ▶ Removing the cooktop from the packaging is a two-person job.
- ▶ Placing the cooktop into the worktop cut-out is a two-person job.
- ▶ Use appropriate aids to prevent damage or injuries to limbs or torso.

## Cooktop extractor



### **DANGER!**

#### **Risk of poisoning from combustion gases!**

If the cooktop extractor is used in exhaust mode, it draws in air from the room in which it is installed as well as from neighbouring rooms. If there is insufficient air supply, low pressure will occur. Toxic gases could be drawn out of the fireplace that depends on the air in the room or extraction ducting and back into the room.

- ▶ Make sure that there is always a sufficient air supply.
- ▶ Only use approved and tested switchgear (e.g. window contact switch, low-pressure monitor) and have them approved by authorised specialists (certified chimney-sweep).



### **DANGER!**

#### **Risk of electric shock!**

Incorrect stripping of the connection cable to external switching devices results in a risk of electric shock.

- ▶ Ensure that the stated stripping lengths are adhered to.

- ▶ Check the appliance for visible damage before installing it.
- ▶ Do not install damaged devices.
- A damaged device is a hazard.
- Repair work must only be carried out by specialists authorised by the manufacturer.

## 2.4 Safety instructions – disassembly and disposal

The device must only be disassembled by trained specialists who are familiar with and comply with the standard national regulations and supplementary regulations of the local utility companies.

Work on electrical components must only be conducted by trained electrical personnel.



### **DANGER!**

#### **Risk of electric shock!**

Incorrectly disconnecting the appliance from the mains results in a risk of electric shock.

- ▶ Securely disconnect the appliance from the mains using LS switches, fuses, automatic circuit breakers or contactors.
- ▶ Use an authorised measuring device to ensure that there is no power to the appliance.



### **DANGER!**

#### **Risk of asphyxiation!**

Packaging components (e.g. film, polystyrene) can be life-threatening for children.

- ▶ Store all packaging components out of reach of children.
- ▶ Dispose of the packaging properly and immediately.

## 2.5 Safety instructions – spare parts



### **WARNING!**

#### **Risk of injury and damage to property!**

Incorrect components can lead to personal injury or damage to the appliance. Modifications, additions or alterations to the appliance can lead to safety risks.

- ▶ Only use original spare parts for repairs.

## 2.6 Intended use

The device cannot be used at altitudes above 2000 m (metres above sea level).

The device is designed exclusively for the preparation of food in private households. This appliance is not intended for:

- Outdoor use
- Installation in vehicles
- Heating rooms
- Use in non-stationary installation sites (e.g. on ships)
- Use with an external timer or a separate remote control system (remote operation)

Any use other than that specified in these operating and installation instructions or any use that goes beyond that which is described here is classed as unintended. BORA does not assume any liability for damages caused by improper use or incorrect operation.

### **All misuse is prohibited!**

### **INFO**

BORA Holding GmbH, BORA Vertriebs GmbH & Co KG, BORA APAC Pty Ltd and BORA Lüftungstechnik GmbH do not assume any liability for damage arising from non-adherence to the safety and warning information.

### 3 Technical data

Parameter	Value
Supply voltage	380-415 V 3N
Frequency	50 Hz
Fuse protection, minimum	1 x 32 A / 2 x 16 A
Total output	7.0 KW
Line-to-line voltage	AC 220 - 240 V / 50 Hz
Main dimensions (width x depth x height) (excl. duct connections)	760 x 515 x 196 mm
Weight (incl. accessories/packaging)	Approx. 25 kg
<b>Cooktop</b>	
Front left single-ring induction cooking zone	210 mm      2100 W
power setting	3000 W
Back left single-ring cooking zone	140 mm      1200 W
Front right single-ring cooking zone	210 mm      2300 W
Back right single-ring cooking zone	140 mm      1200 W
Power levels	1 - 9, power setting
<b>Cooktop energy consumption</b>	
Cooking zone 1 (210 mm)	187,6 (Wh/kg)
Cooking zone 2 (140 mm)	177,5 (Wh/kg)
Cooking zone 3 (210 mm)	219,7 (Wh/kg)
Cooking zone 4 (140 mm)	181,2 (Wh/kg)
Total	191,5 (Wh/kg)
<b>Extraction system (BHA)</b>	
Maximum flow volume	646.9 m <sup>3</sup> /h
Maximum static pressure	339 Pa
Power control	1 - 2, power setting
Exhaust air connection (BHA)	222 x 40 x 89 mm
<b>Recirculation system (BHU)</b>	
Maximum flow volume	624.6 m <sup>3</sup> /h
Maximum static pressure	341 Pa
Power control	1 - 2, power setting
Recirculation connection (BHU)	650 x 90 mm
<b>Recirculation filter</b>	
Filter area	2 x 0.4m <sup>2</sup>
Filter capacity	150 operating hours
Service life	1 year

Tab. 3.1 Technical data

#### Device dimensions BHA

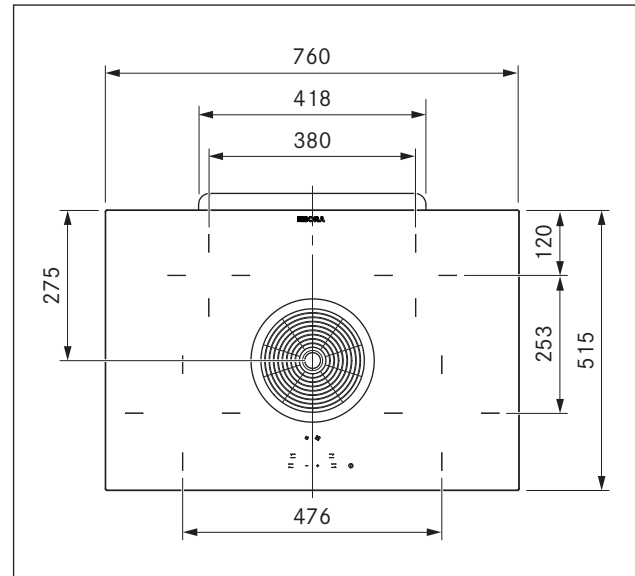

Fig. 3.1 BHA Device dimensions aerial view

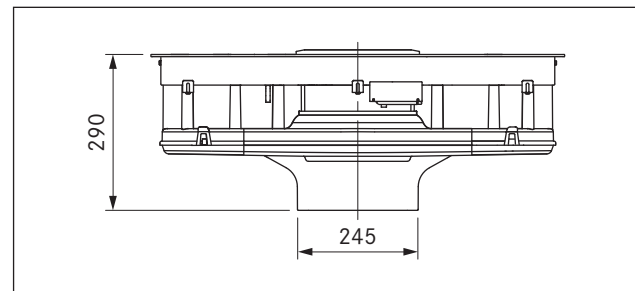

Fig. 3.2 BHA Device dimensions front view

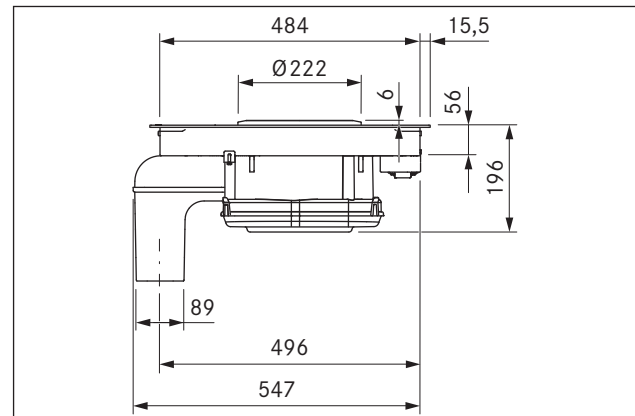

Fig. 3.3 BHA Device dimensions side view

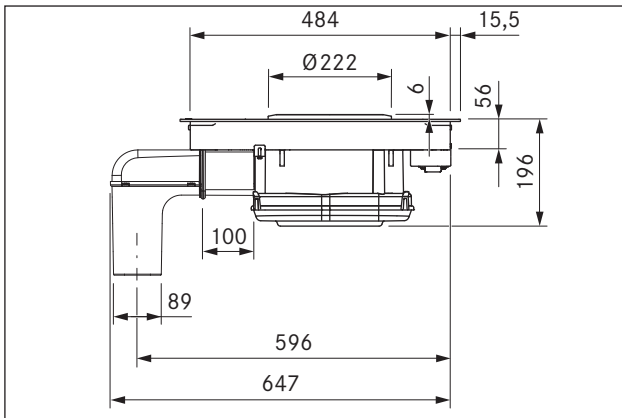

Fig. 3.4 Device dimensions with cable extension (BHA + BLAVH1)

### Device dimensions BHU

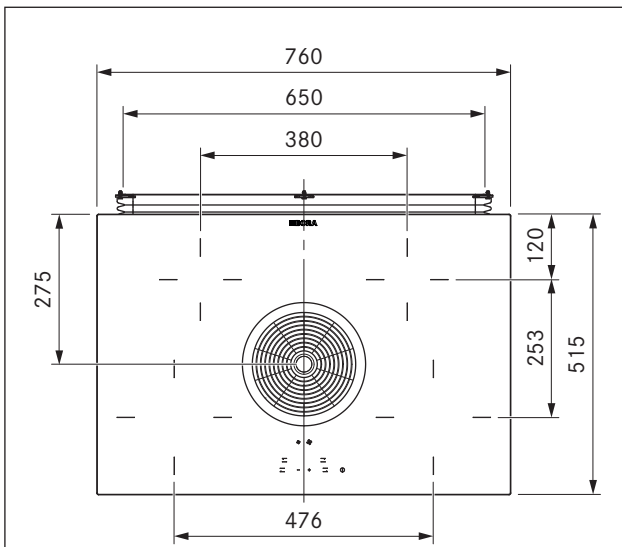

Fig. 3.5 BHU Device dimensions aerial view

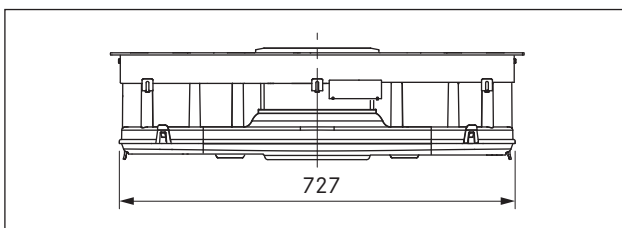

Fig. 3.6 BHU Device dimensions front view

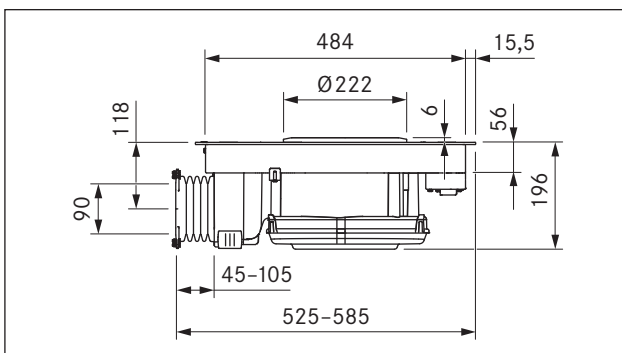

Fig. 3.7 BHU Device dimensions side view

## 4 Energy label

Product description			
Glass ceramic cooktop with 4 cooking zones and an integrated cooktop extractor	BHA	BHU	
Operating mode	Exhaust air	Recirculation	
Energy consumption	Value	Value	EN standard
Annual energy consumption ( $AEC_{hood}$ )	87,5 kW/a	94,2 kW/a	61591
Energy efficiency class	C	*	61591
Flow volume			
Fluid dynamic efficiency ( $FDE_{hood}$ )	15,7	13,1	61591
Fluid dynamic efficiency class	D	*	61591
Lighting			
Lighting efficiency ( $LE_{hood}$ )	* lx/Watt	* lx/Watt	*
Lighting efficiency class	*	*	*
Grease filtering			
Level 2 maximum ( $GFE_{hood}$ )	88,5 %	88,5 %	61591
Class level 2 normal	B	*	61591
Grease filtering (additional details)			
Level P maximum ( $GFE_{hood}$ )	93 %	93 %	61591
Class level P maximum	B	*	61591
Flow volume			
Air flow level 1 minimum	342 m <sup>3</sup> /h	* m <sup>3</sup> /h	61591
Air flow level 2 normal	497 m <sup>3</sup> /h	* m <sup>3</sup> /h	61591
Air flow level P maximum ( $Q_{max}$ )	647 m <sup>3</sup> /h	624 m <sup>3</sup> /h	61591
Sound power level			
Level 1 minimum	55 dB(A)	* dB(A)	60704-2-13
Level 2 normal	64 dB(A)	65 dB(A)	60704-2-13
Level P maximum	69 dB(A)	70 dB(A)	60704-2-13
Sound pressure level (additional details)			
Level 1 minimum	43 dB(A)	* dB(A)	**
Level 2 normal	51 dB(A)	53 dB(A)	**
Level P maximum	57 dB(A)	57 dB(A)	**
Details according to 66/2014			
Power consumption in off mode ( $P_o$ )	< 0,5 W	< 0,5 W	61591
Time increase factor	1,4	1,5	61591
Energy efficiency index ( $EEl_{hood}$ )	79,9	85,6	61591
Air flow rate at the best efficiency point ( $Q_{BEP}$ )	370,8 m <sup>3</sup> /h	320,8 m <sup>3</sup> /h	61591
Pressure at the best efficiency point ( $P_{BEP}$ )	261 Pa	253 Pa	61591
Electric power input at the best efficiency point ( $W_{BEP}$ )	171,2 W	172,1	61591

Tab. 4.1 Energy label details

(The recirculation information is optional and not subject to mandatory inclusion on the label)

\* This specification is not applicable for this product.

\*\* The sound pressure level has been determined from a distance of 1 m (distance-dependent level recording) on the basis of the sound power levels established in EN 60704-2-13.

## 5 Device description

Observe all safety and warning information during operation (see the Safety chapter).

The cooktop with cooktop extractor has the following features:

### Cooktop:

- power setting
- Automatic heat up function
- Warming function
- Timer functions
- Residual heat display
- Child safety lock
- Safety shut-down

### Cooktop extractor:

- Touch-operated power control
- Automatic after-run
- Safety shut-down
- Filter service display

Depending on your purchase decision, the cooktop extractor is operated as an exhaust air or a recirculating version.



### Exhaust operation

The air suctioned away by the cooktop is purified by the grease filter and expelled into the open air via a duct system.

The exhaust air must not be expelled into:

- a smoke or exhaust gas flue that is in operation
- a shaft used to aerate areas in which fireplaces are installed

If the exhaust air is fed into a smoke or exhaust air flue that is not in operation, the installation must be checked and approved by a qualified heating engineer.



### Recirculated air mode

The air suctioned away by the cooktop is purified by the grease filter and an activated charcoal filter and fed back into the room in which the appliance is installed.

To prevent odours in the recirculated air, an activated charcoal filter must be used. For hygiene and health reasons, the activated charcoal filter must be replaced at the recommended intervals (see the Cleaning and maintenance section).

**INFO** When using recirculated air, always ensure sufficient ventilation and aeration in order to expel any humidity.

The filter in the activated charcoal filter is made from special activated charcoal, which is ideal for trapping cooking odours.

### 5.1 Structure

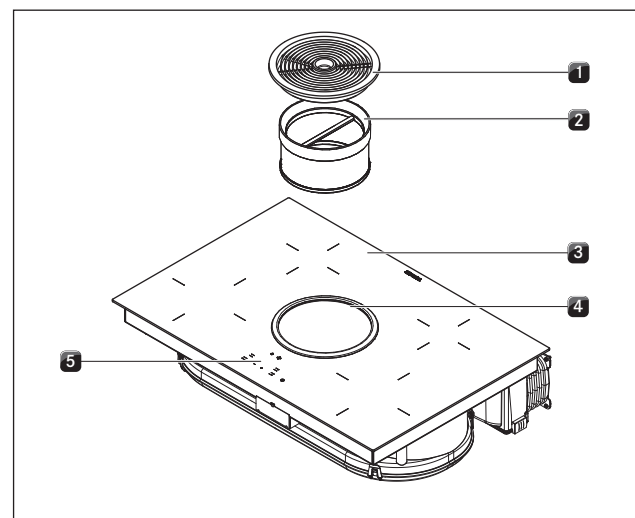

Fig. 5.1 Cooktop

- [1] Inlet nozzle
- [2] Stainless steel grease filter
- [3] Cooktop
- [4] Suction opening
- [5] Operating panel

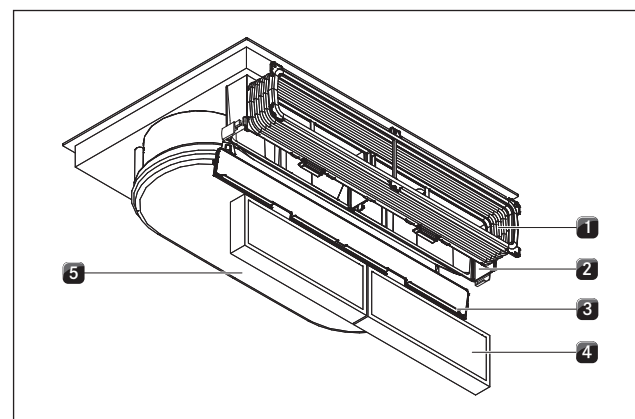

Fig. 5.2 Cooktop extractor recirculation (BHU)

- [1] Flexible duct
- [2] Activated charcoal filter housing
- [3] Activated charcoal filter housing cover
- [4] Activated charcoal filter
- [5] Air guiding housing with housing base



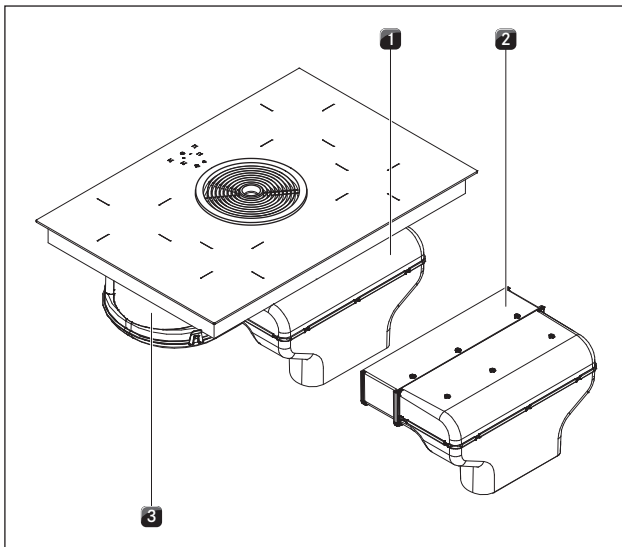

Fig. 5.3 Cooktop extractor exhaust air (BHA)

- [1] Exhaust air arc with duct connection for BORA Ecotube
- [2] Horizontal exhaust air extension
- [3] Air guiding housing with housing base

## 5.2 Operating panel and operating principle

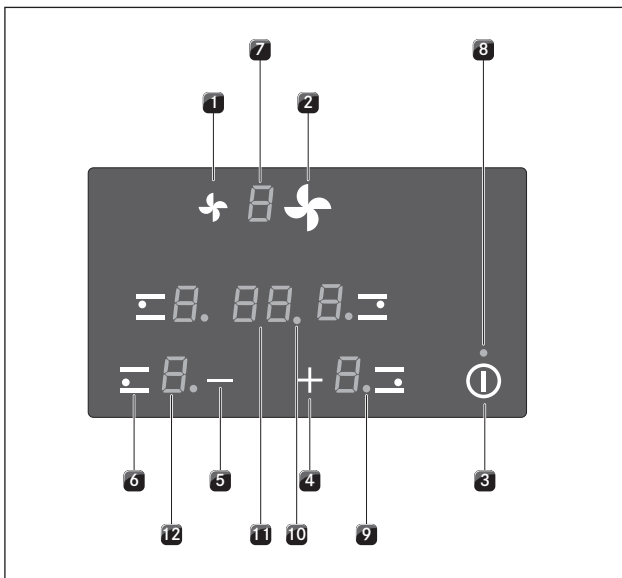

Fig. 5.4 Operating panel

### Sensor keys:

- [1] Reduce fan power level
- [2] Increase fan power level
- [3] switch cooktop on/off
- [4] increase power level  
Increase timer value
- [5] reduce power level  
Decrease timer value
- [6] Select cooking zone

### Display fields:

- [7] Fan level indicator  
Filter service display
- [8] Operating indicator light
- [9] Cooking zone indicator lamp
- [10] Egg timer indicator light
- [11] Timer display
- [12] Cooking zone indicator

Display panel	Display	Meaning
Fan level indicator	0	Fan off
	1...2	Setting
	P	power setting
	n	After-run
Cooking zone indicator	1...9	Power level
	P	power setting
	u	Heat retention level
	H	Residual heat display: Cooking zone is switched off but still hot (temperature > 60°C)
	L	Child safety lock active
	R	Automatic heat up function activated
Operating indicator light	On	Cooktop switched on
	Off	Cooktop switched off
Cooking zone indicator lamp	On	Timer (egg timer) activated
	Flashes	Timer selected (00); no time set; timer with the lowest value (several timers active); timer run down
	Off	Timer off
	Off	Timer off
Timer display	01...99	Set minutes for short time (egg timer) or automatic cut-off
	00	Timer on; no time set

Tab. 5.1 Meaning of displays

### Touch control

The operating panel is fitted with electronic sensor buttons and display panels. The sensor buttons respond to finger contact.

You operate the device by touching the corresponding sensor key with your finger. Keep the finger pressed on the sensor key until you either hear an acoustic signal or the display changes accordingly.

## 5.3 How the cooking zone works

Under the cooking zone is a radiant heating element with a heating tape. When the cooking zone is switched on, the heating tape generates radiant heat, which directly radiates to the pot thus heating it up.

### 5.3.1 Power levels

Activity	Power level
Keeping cooked meals warm	u
Melting of butter and chocolate, breaking up gelatine	1
Keeping sauces and soups warm, soaking rice	1-3
Cooking potatoes, pasta, soups, ragouts, steaming fruit, vegetables and fish, defrosting food	2-6
Frying in coated pans, moderate frying (without overheating the fat) of pork cutlets, fish	6-7
Heating up fat, browning fish, cooking thickened sources and soups, making omelettes	7-8
Cooking large quantities of liquid, browning steaks	9
Heating up water	P

Tab. 5.2 Recommendations for power levels

The specifications provided in the table are standard values.

Depending on the cookware and filling quantity, it is recommended to either decrease or increase the power level.

### 5.3.2 power setting

The front, left cooking zone (hyper cooking zone) has a power-enhancing power setting.

The power setting can be used in order to quickly heat up large quantities of water. If the power setting is activated, the cooking zones will run at extra high power. After 30 minutes, the cooking zone is automatically switched to power level 9.

If one cooking zone is operated with the P power setting, then the operation of the second cooking zone on this side is possible at a maximum of power level 5.

**INFO** Never heat up oil, fat and the like at this power setting. The bottom of the pan can overheat due to the high power output.

### 5.3.3 Timer functions

You can use 2 timer functions:

- Short-time timer (egg timer), no automatic switching off of a cooking zone.
- Automatic cut-off for automatically switching off a cooking zone.

### 5.3.4 Suitable cookware

**INFO** The heating and heat through time for the base of the cookware as well as the cooking results are significantly influenced by the structure and material of the cookware.



Cookware with this symbol is suitable for radiant heating elements.

The cookware used for radiant heating surfaces must be metal and have good heat conducting properties.

Suitable cookware is made of:

- Stainless steel, copper or aluminium
- enamelled steel
- cast iron

► Pay attention to the cookware bottom. The base of the cookware should not show any sign of curvature. Due to incorrect temperature monitoring of the hob caused by the air gap between the cookware and the temperature sensor underneath the hob, overheating may arise. The bottom of the cookware must not have any sharp grooves or sharp edges to avoid scratching the cooktop.

► Place the cookware (without a mat or similar) directly onto the glass ceramic.

## 5.4 How the cooktop extractor works

### 5.4.1 power setting

The cooktop extractor has a power-enhancing power setting.

This power setting makes it possible to suction away high levels of cooking vapours more quickly. After 10 minutes, the power setting is automatically switched to power level 2.

### 5.4.2 Automatic after-run

The cooktop extractor fans continue to run at level 1 and switch off automatically after 20 minutes.

### 5.4.3 Filter service display

The filter service display becomes active after the cooktop extractor has operated for 150 hours. The activated charcoal filters have reached the end of their service life (with recirculation only) and the stainless steel grease filter needs to be thoroughly cleaned.

- A flashing F is displayed in the filter service display.
- The filter service display is shown every time the cooktop extractor is switched on and remains active until the filter has been changed and the filter service display is reset.
- The cooktop extractor can still be operated without limitations.

## 5.5 Safety devices

### 5.5.1 Residual heat display

**INFO** While *H* is displayed in the cooking zone indicator (residual heat display), do not touch the cooking zone or place any heat-sensitive objects on top of it. Risk of burns and fire!

After switching it off, the cooking zone remains hot. *H* is displayed in the cooking zone indicator (residual heat indicator). The cooking zone indicator will go out after sufficient cooling time (temperature < 60°C).

### 5.5.2 Safety shut-down

#### Cooking zone

Each cooking zone is switched off automatically when the cooking zone exceeds the maximum operating duration at a power level (see table 4.3). *H* (residual heat display) is then displayed in the cooking zone indicator (see the Device description section).

Power level	1	2	3	4	5	6	7	8	9
Switch off after x hours	6	6	5	5	4	1.5	1.5	1.5	1.5

Tab. 5.3 Overview of the safety shut-down

- ▶ Switch the cooking zone back on (see Operating control) if you want to put the cooking zone back into operation.

#### Cooktop extractor

The cooktop extractor switches off automatically if no buttons are pressed for 120 minutes.

### 5.5.3 Overheating protection

The device is fitted with overheating protection.

The overheating protection can be triggered if:

- Cookware is heated up empty.
- Oil or fat is heated on high power.
- A hot cooking zone is switched on again after a power cut.
- There is insufficient ventilation below the cooktop (see Cooktop air intake).

Before the overheating damages the electronics, one of the following measures is taken:

- The power level can no longer be increased.
- The power level set is reduced.
- The cooktop switches off completely.

After a sufficient cooling period, the cooktop can be used again in full.

### 5.5.4 Automatic switch-off if the button is pressed and held

The cooktop will be switched off automatically when one or more sensor buttons are touched for longer than 10 seconds (finger contact, objects, soiling).

- The display shows *Er-03*.
- After a few seconds, the cooktop will switch off.
- ▶ Remove the finger or object from the cooktop.
- ▶ Clean the cooktop as required.
- ▶ Where necessary, switch the cooktop back on.

### 5.5.5 Child safety lock

The child safety lock prevents the cooktop from being switched on automatically. The child safety lock can only be activated when the cooktop is switched on and all cooking zones have been switched off (see the Operation chapter).

## 6 Assembly

- ▶ Observe all safety instructions and warnings (see Safety chapter).
- ▶ Follow the enclosed manufacturer's information.

<b>INFO</b>	The mains connection cord must be provided by the customer.
<b>INFO</b>	The device may not be installed above cooling devices, dishwashing machines, stoves, baking ovens as well as washing and drying machines.
<b>INFO</b>	The contact surface of the worktops and the wall sealing strip must be made of a heat-resistant material (up to approx. 100 °C).
<b>INFO</b>	Worktop cut-outs must be moisture-sealed using suitable means and, where necessary, fitted with a thermal insulator.
<b>INFO</b>	The integrated cooktop extractor must not be used with other cooktops.

### 6.1 Checking the scope of delivery

Name	Quantity
Hyper glass ceramic cooktop with integrated cooktop extractor	1
Air inlet nozzle	1
Stainless steel grease filter	1
BAKF activated charcoal filter (only BHU)	2
Flexible duct (only BHU)	1
EURO screws (only BHU)	6
Duct extension for extracted air, horizontal BLAVH1 (only BHA)	1
Mounting brackets	5
Sealing tape	1
Glass ceramic scraper	1
Cable routing clips	3
Operating and assembly manual	1
Lenshead screws	5
Drilling template	1
Height compensation plate set	1

Tab. 6.1 Scope of delivery

- ▶ Check the scope of delivery for damage and make sure it is complete.
- ▶ If there are any missing or damaged parts, please notify BORA Customer Services immediately.
- ▶ Do not under any circumstances install parts which are damaged.

- ▶ Dispose of transport packaging in the proper manner (see Decommissioning, Disassembly and Disposal chapter)

### 6.2 Tool and aids

The following tools are required for the correct installation of the cooktop:

- Pencil
- Drill or cordless drill with a 5 mm wood bit (for the back wall)
- Compass saw or handsaw
- Drilling template for cut-out on back wall (included)
- Phillips screwdriver Z2
- Silicone sealing compound for sealing cutting surfaces

### 6.3 Assembly instructions

#### 6.3.1 Safety distances

- ▶ Maintain the following safety distances:

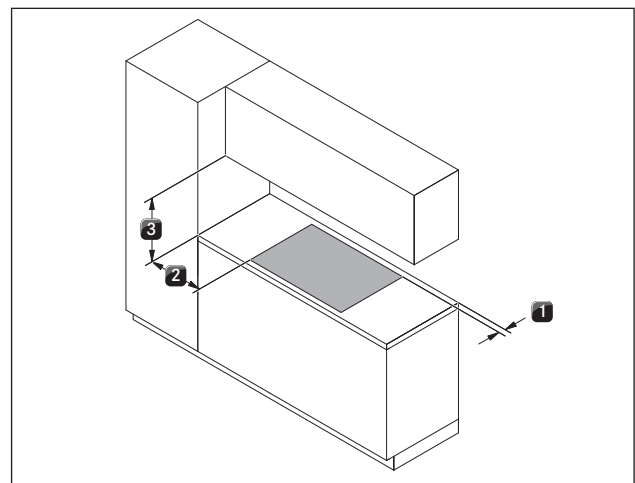

Fig. 6.1 Recommended minimum clearances

- [1] Minimum distance of 50 mm at the back between worktop cut-out and the rear edge of the worktop.
- [2] Minimum distance of 300 mm from the left and right of the worktop cut-out to the adjacent cabinet or wall.
- [3] Minimum distance of 600 mm between the worktop and the wall unit. A minimum clearance of 1000 mm is recommended for ergonomic reasons.

#### 6.3.2 Work surface and kitchen units

- ▶ Create the worktop cut-out taking the specified cut-out dimensions into account.
- ▶ Make sure that the cutting surfaces of the worktops are properly sealed.
- ▶ Observe the instructions provided by the worktop manufacturer.
- Cross bars on the unit in the area of the worktop cut-out may need to be removed.

- A false floor underneath the cooktop with integrated cooktop extractor is not needed.
- The drawers and/or shelves in the floor unit must be removable.
- A return flow aperture > 500 cm<sup>2</sup> is required in the kitchen units for recirculation appliances (e.g. by shortening the plinth boards or using suitable slatted plinths).
- The power socket is underneath the device on the front.

### 6.3.3 Cooktop air intake

The components in the cooktop which generate heat are automatically cooled. The warm air is extracted by fans (cold air flow).

**INFO** In order to retain the full functionality of the cooktop in the long term, there must be sufficient ventilation underneath the cooktop.

**INFO** The performance of the cooktop is impaired or the cooktop overheats if the warm air below the cooktop cannot escape.

**INFO** If the cooktop overheats, performance is reduced or the cooktop switches off completely (see Overheating protection).

**INFO** For sufficient air intake, an opening cross-section in the kitchen units of at least 50 cm<sup>2</sup> is recommended.

► Ensure there is sufficient ventilation underneath the cooktop.

**INFO** If there are plans for a cable protection floor (false floor) below the device, this must not impede the ventilation.

## 6.4 Dimensions of cut-out for cooktop

### Worktop overhang

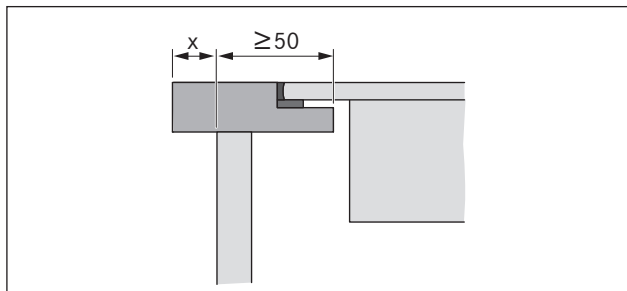

Fig. 6.2 Worktop overhang

► Please note the worktop overhang x when creating the worktop cut-out. Applies to flush installation and surface mounting.

### Flush installation

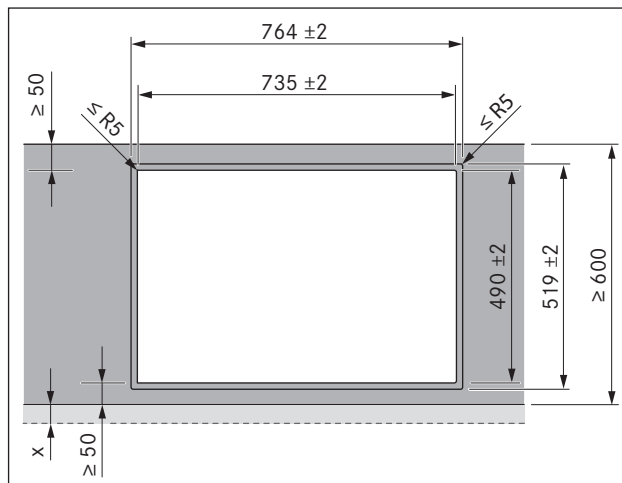

Fig. 6.3 Dimensions of cut-out for flush installation

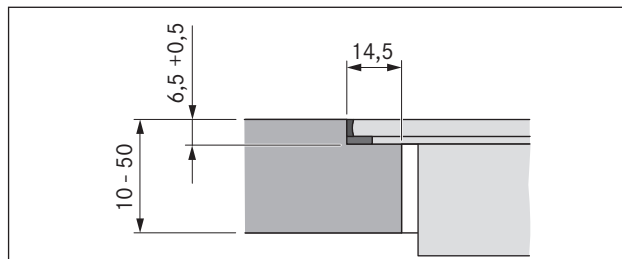

Fig. 6.4 Dimensions of groove for flush installation

### Surface installation

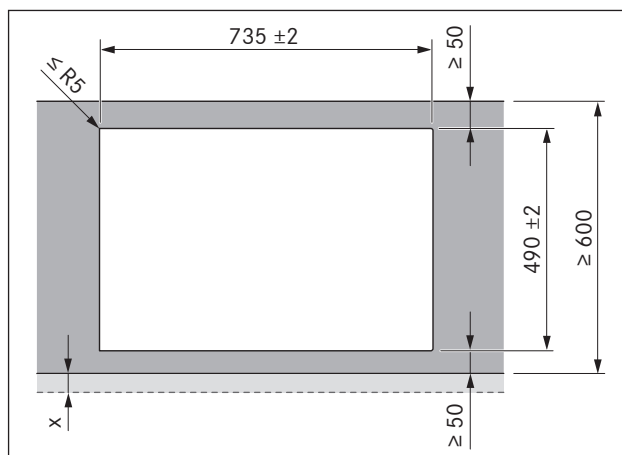

Fig. 6.5 Dimensions of cut-out for surface installation

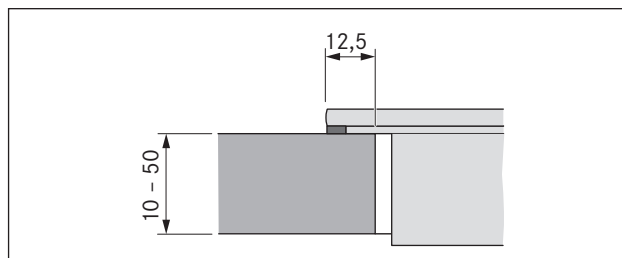

Fig. 6.6 Dimension of support for surface installation

## 6.5 Attaching the sealing tape

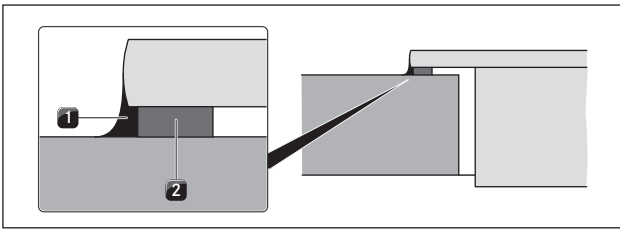

Fig. 6.7 Sealing tape, surface installation

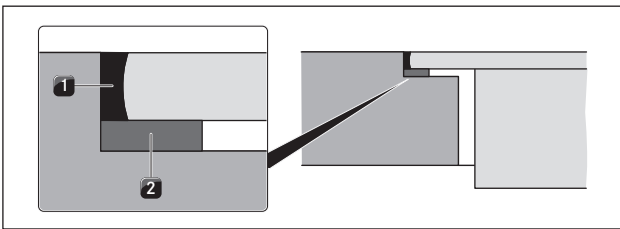

Fig. 6.8 Sealing tape, flush installation

- [1] Black heat-resistant silicone sealing compound
- [2] Sealing tape

- ▶ With surface installation, attach the included sealing tape [2] on the underside of the cooktop before installing it. Do not leave any gaps.
- ▶ With flush installation, attach the sealing tape [2] to the horizontal cutting edge in the worktop cut-out, even if you seal the cooktop with a silicone sealing compound [1] or similar.
- ▶ Note down the type designation and build number of the cooktop (FD number) on the back of this manual. Both designations can be found on the nameplate on the underside of this cooktop.

## 6.6 Installing the air recirculation version (BHU)

**INFO** There must be a minimum clearance of 25 mm for the vertical return flow aperture.

**INFO** There must be a return flow aperture of at least 500 cm<sup>2</sup>.

When the cooktop extractor is exclusively used in recirculated air mode, it is possible to operate it with an open furnace without any additional safety measures being required.

## Installation dimensions

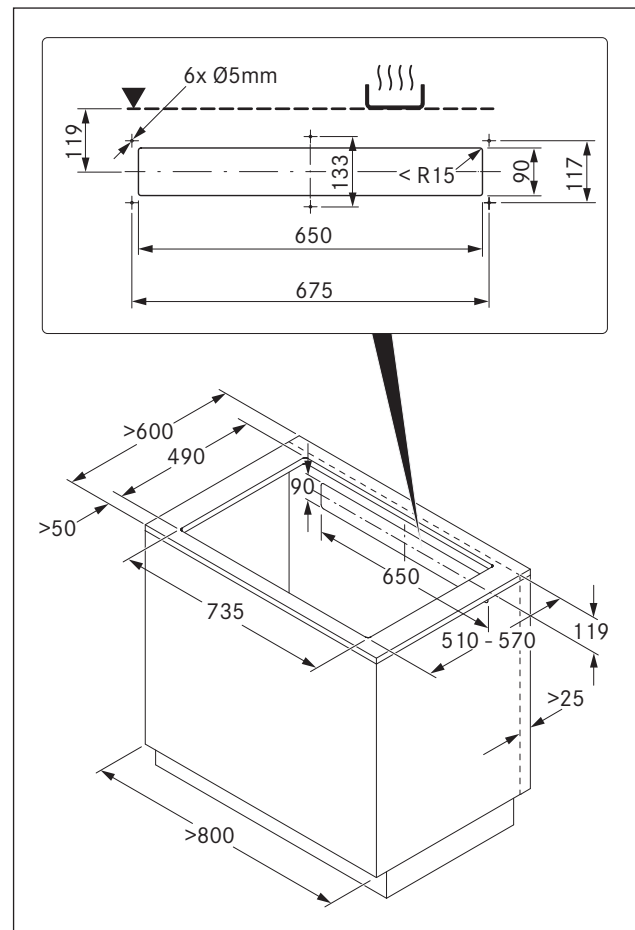

Fig. 6.9 Dimensions of furniture, recirculated air

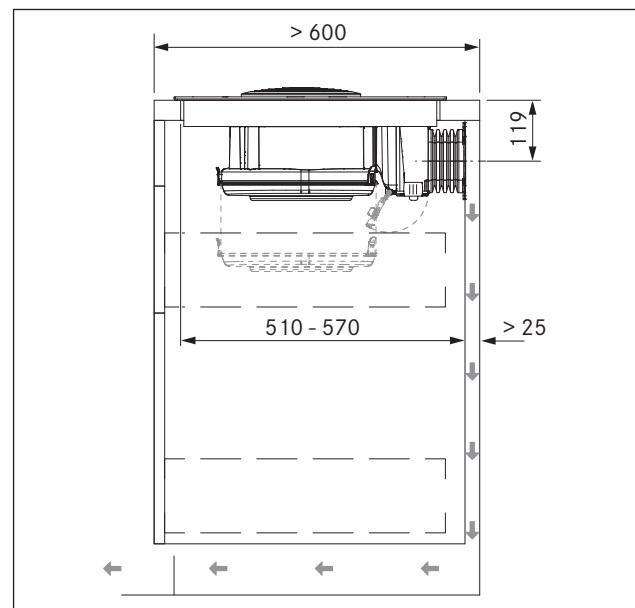

Fig. 6.10 Installation dimensions for recirculated air, worktop depth 600 mm

- The floor unit must have a continuous rear wall so that the returned recirculated air is not directed into the front furniture body compartment.
- There must be a cut-out in the rear wall.
- A minimum clearance of 25 mm between the rear wall of the furniture body and an adjacent piece of furniture or room wall must be observed for the return flow aperture.

#### Preparing the rear wall of the furniture

- ▶ Adjust the rear wall according to the required installation dimensions.
- ▶ You may need to move the rear wall.
- ▶ Where necessary, extend the height of the rear wall so that the furniture body is closed to the front.

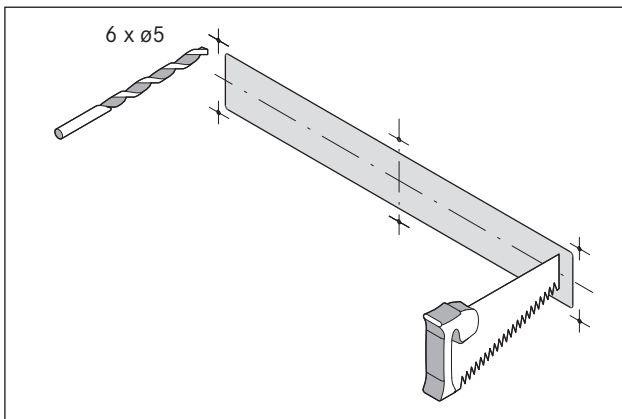

Fig. 6.11 Cut-out and connection bores

- ▶ Using the included drilling template, draw the return flow aperture and the connection bores in the middle of the cooktop based on the installation dimensions.
- ▶ Saw out the return flow aperture.
- ▶ Rough-drill the connection bores.
- ▶ Decrease the height of the skirting boards or create corresponding apertures in the base.

#### Screwing on the flexible duct

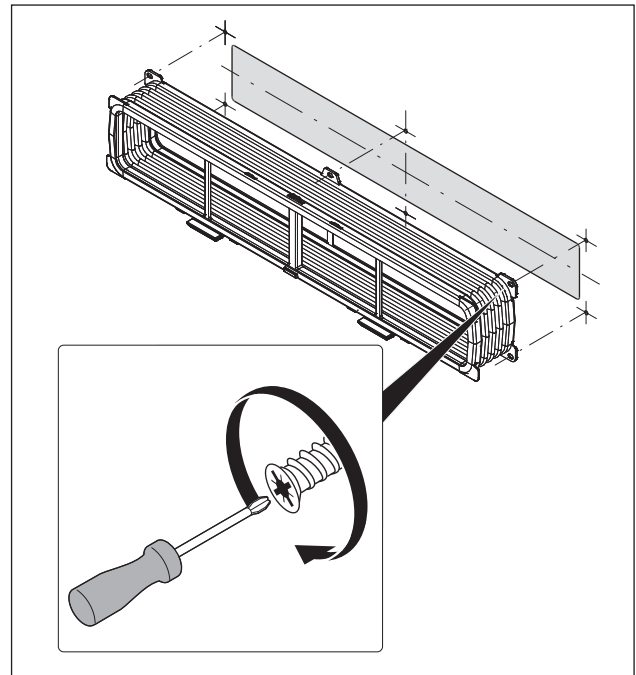

Fig. 6.12 Flexible duct with 6 EURO screws 6.3x10 mm

- ▶ Using a screwdriver (not a cordless drill) screw the flexible duct into the rear wall of the furniture until hand-tight.

#### Inserting the cooktop

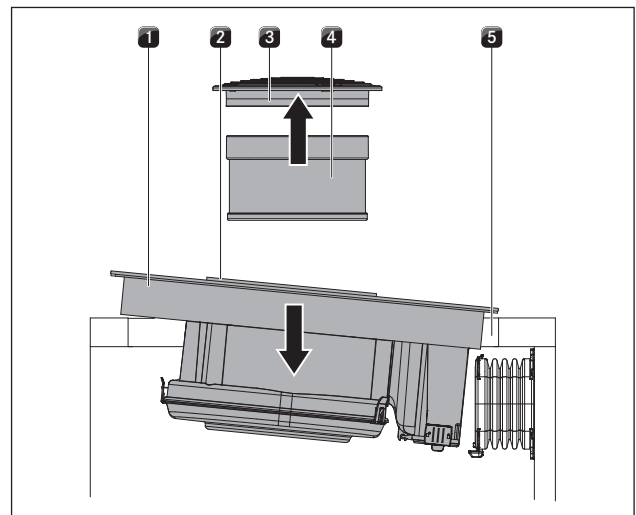

Fig. 6.13 Insert the cooktop at an angle

- [1] Cooktop
- [2] Suction opening
- [3] Air inlet nozzle
- [4] Stainless steel grease filter
- [5] Worktop cut-out
- [6]

- ▶ Before inserting, remove the air inlet nozzle [3] and the stainless steel grease filter [4].
- ▶ Use the suction opening [2] as a handle when inserting.



- ▶ Lift the cooktop [1] diagonally into the worktop cut-out [5]
- ▶ Place the cooktop [1] in the centre of the worktop cut-out [5].
- ▶ Align the cooktop precisely.

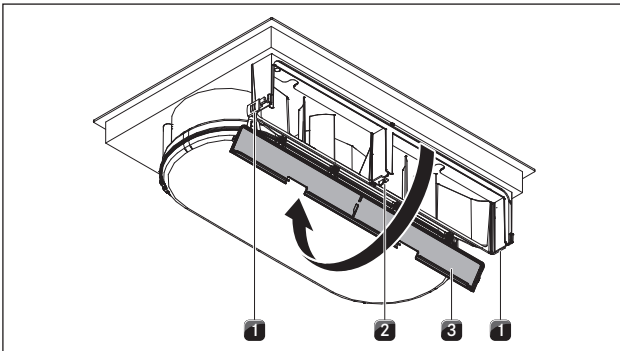

Fig. 6.14 Opening the housing cover

- [1] Outer locks
- [2] Middle lock
- [3] Housing of the activated charcoal filter

- ▶ Fold down the cover of the activated charcoal filter housing [3] from below by opening the two outer locks [1] and the middle lock [2].

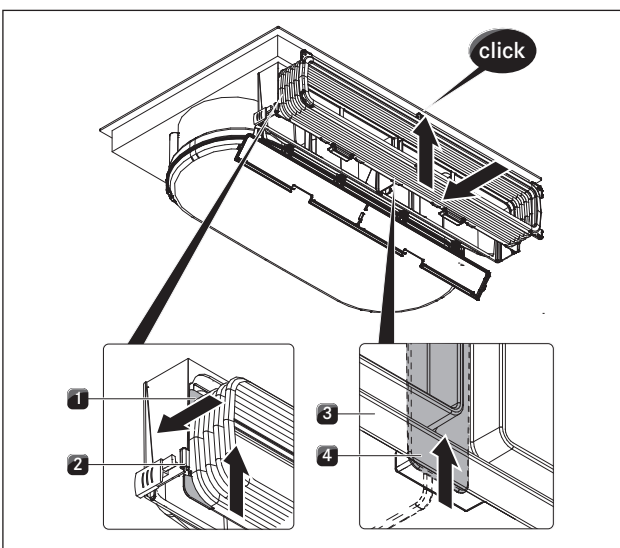

Fig. 6.15 Hooking in the frame of the flexible duct

- [1] Position shackles
- [2] Retaining groove on the activated charcoal filter housing
- [3] Flexible duct frame
- [4] Bottom lock

- ▶ Hang the frame of the flexible duct into the retaining groove on the activated charcoal filter housing [2].
- ▶ Make sure that the two lateral position shackles [1] are in the guide.
- ▶ Slide the frame [3] up until the bottom lock [4] and the upper lock engage in the middle.
- ▶ Make sure that the frame is fitted all around in the groove of the activated charcoal filter housing.

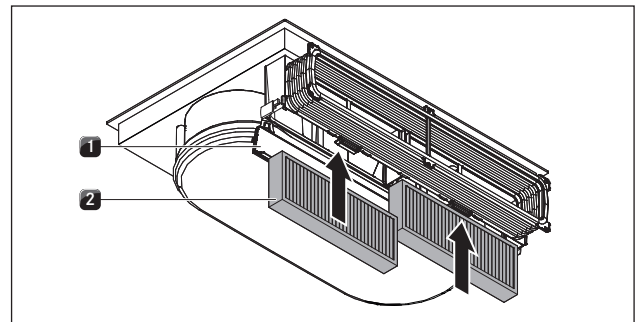

Fig. 6.16 Inserting the activated charcoal filter

- [1] Housing cover of the activated charcoal filter
- [2] Activated charcoal filter

- ▶ Remove the packaging from the activated charcoal filters.
- ▶ Insert the two activated charcoal filters [2] from below.
- ▶ Note the flow direction of the filter. This is indicated by an arrow.
- ▶ Close the cover to the housing [1].

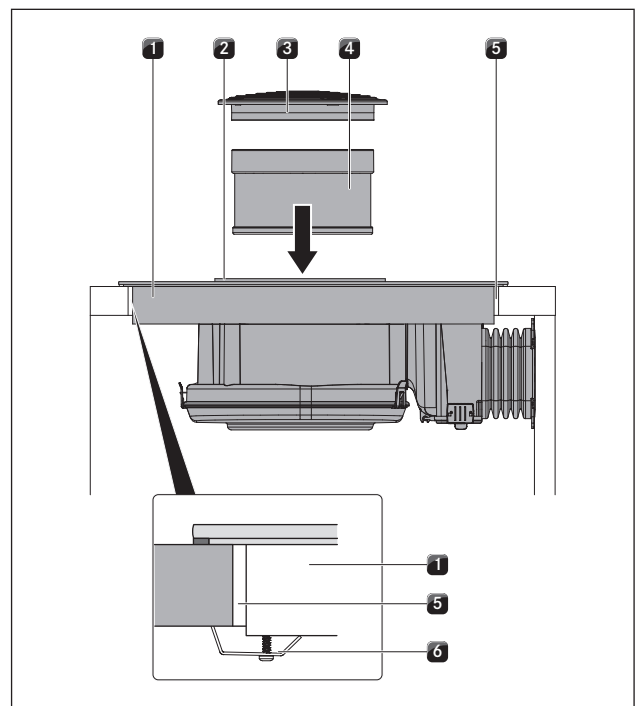

Fig. 6.17 Securing the cooktop in the middle

- [1] Cooktop
- [2] Suction opening
- [3] Air inlet nozzle
- [4] Stainless steel grease filter
- [5] Worktop cut-out
- [6] Mounting bracket

**For surface installation**

- ▶ Make sure that the sealing tape of the cooktop is resting on the worktop.

**For flush installation**

- ▶ Make sure that the sealing tape of the cooktop is sealed well all the way round.

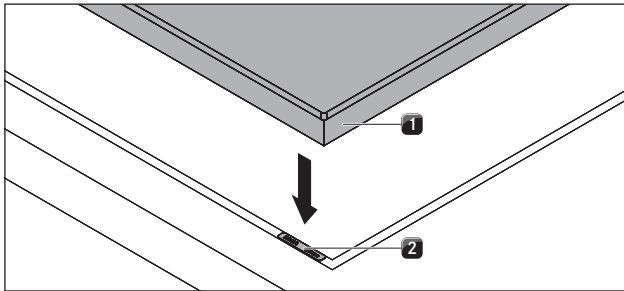

Fig. 6.18 Height adjustment plates

- [1] Cooktop  
[2] Height adjustment plates

- ▶ If necessary insert height adjustment plates [2].
- ▶ Fasten the cooktop using the mounting brackets [6] at the worktop.
- ▶ Afterwards, insert the stainless steel grease filter [4] and air inlet nozzle [3].
- ▶ Seal the surrounding gap with a black heat-resistant silicone sealing compound.

## 6.7 Installing exhaust air duct variant (BHA)

**INFO** National and regional laws and regulations must be followed when executing the exhaust air duct. Sufficient intake air must be provided.

### 6.7.1 Using the cooktop extractor with a fireplace which does not depend on room air

Fireplaces depending on room air (e.g. gas, oil, wood or coal-fired heaters, continuous-flow water heaters, instantaneous water heaters) draw in air from the room in which they are installed and discharge the exhaust fumes to the outside via an exhaust system (e.g. chimney). When the cooktop extractor is used for exhaust air operation, it draws in air from the room it is installed in and from neighbouring rooms. If there is insufficient air, an underpressure will occur. Toxic gases could be drawn out of the chimney or extraction duct and back into the room.

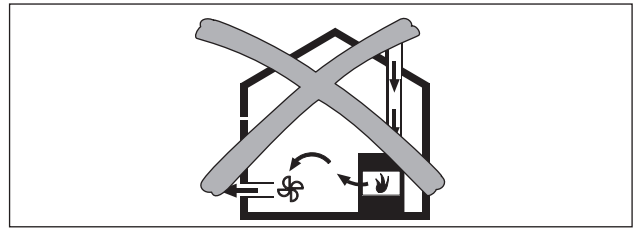

Fig. 6.19 Incorrect exhaust air system installation

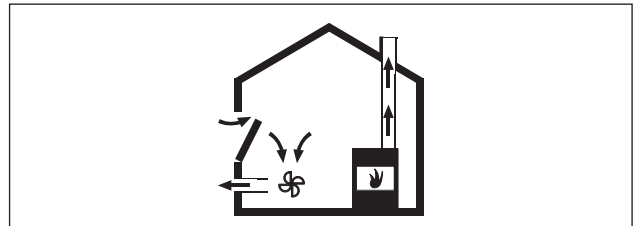

Fig. 6.20 Correct exhaust air system installation

- ▶ When running the cooktop extractor in the room in which a fireplace is installed, make sure that
  - the maximum underpressure is 4 Pa (4 x 10<sup>-5</sup> bar),
  - a safety-related device (e.g. window contact switch, minimum pressure controller) ensuring that a sufficient supply of fresh air is guaranteed must always be used,
  - the exhaust air may not be ducted into a chimney that is used for exhaust gases of devices operated with gas or other combustibles,
  - the installation has been inspected and signed off by a qualified professional (e.g. chimneysweep).

## Installation dimensions

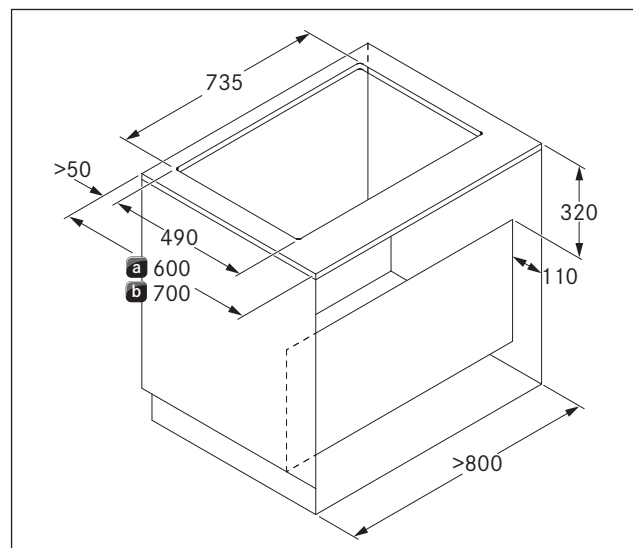

Fig. 6.21 Furniture dimensions, exhaust air

- [a] Worktop depth from 600 mm  
[b] Worktop depth from 700 mm

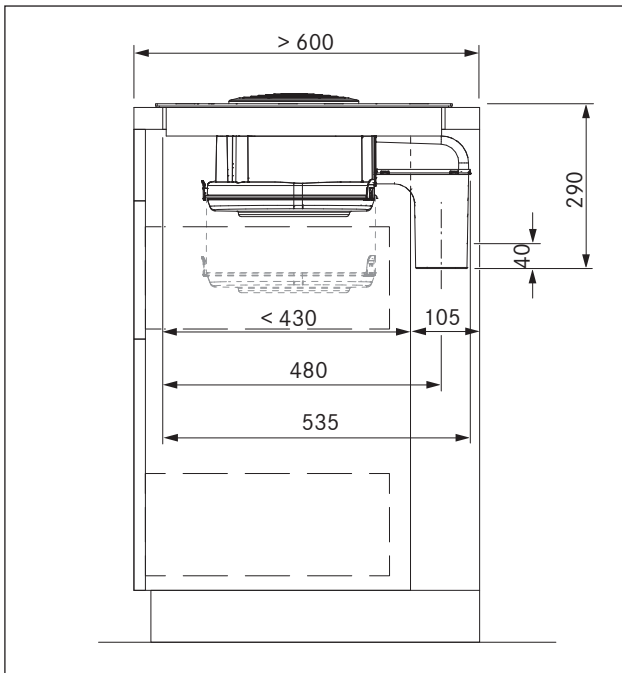

Fig. 6.22 Installation dimensions for exhaust air, worktop depth 600 mm

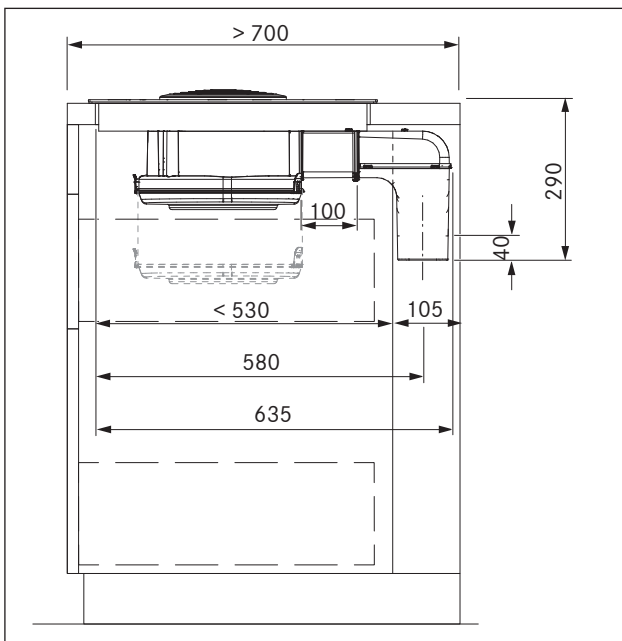

Fig. 6.23 Installation dimensions for exhaust air, worktop depth 700 mm

**Installation conditions**

- The rear wall of the floor unit must be adjusted for the exhaust air duct.
- A minimum clearance of 110 mm between the rear wall of the furniture body and an adjacent piece of furniture or wall must be observed for the duct.
- The exhaust air must be directed to the outside in appropriate exhaust air ducts.
- The minimum cross-section of the exhaust air ducts must be 176 cm<sup>2</sup>. This equates to a cylindrical tube with a diameter of 150 mm.

- The maximum exhaust air duct length is 6 m.
- Planning information for the installation of the exhaust air ducts are provided in the BORA ventilation instructions.

**Preparing the rear wall of the furniture**

- ▶ Before carrying out the installation at the floor unit, check the required installation dimensions for the device and the planned duct system.
- ▶ Adjust the position of the rear wall according to the required installation dimensions as necessary.

**Extending the exhaust air duct**

**INFO** The exhaust air duct can optionally be extended by 100 mm to the rear using the supplied horizontal extension BLAVH1.

- ▶ Remove the air inlet nozzle and stainless steel grease filter.
- ▶ With the glass ceramic panel facing downwards, place the cooktop onto a clean and protective surface (e.g. cardboard, packaging material) to prevent damage to the glass ceramic panel.

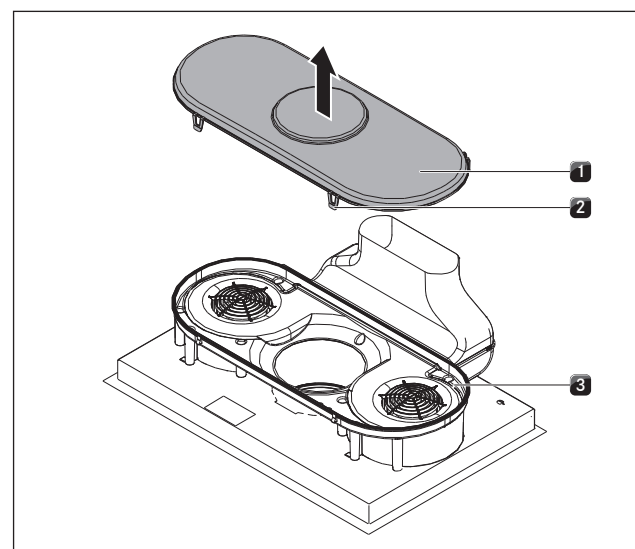

Fig. 6.24 Removing the housing base

- [1] Housing base
- [2] Locks
- [3] Air guiding housing

- ▶ Open the 4 locks [2].
- ▶ Remove the housing base [1] from the air guiding housing [3].

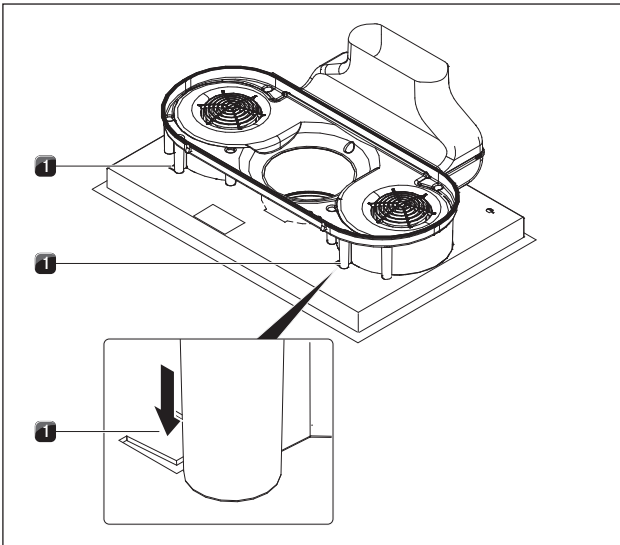

Fig. 6.25 Releasing the position lock

[1] Shackles for position lock

- Using a screwdriver, press the shackles [1] downwards left and right to release the position lock.

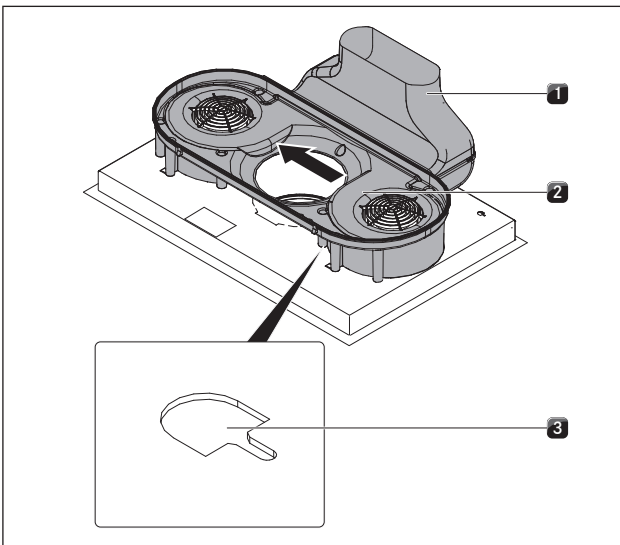

Fig. 6.26 Moving the air guiding housing

[1] Exhaust air arc  
[2] Air guiding housing  
[3] Support opening

- Move the air guiding housing [2] together with the exhaust air arc [1] as far as the left-hand edge of the support opening [3].

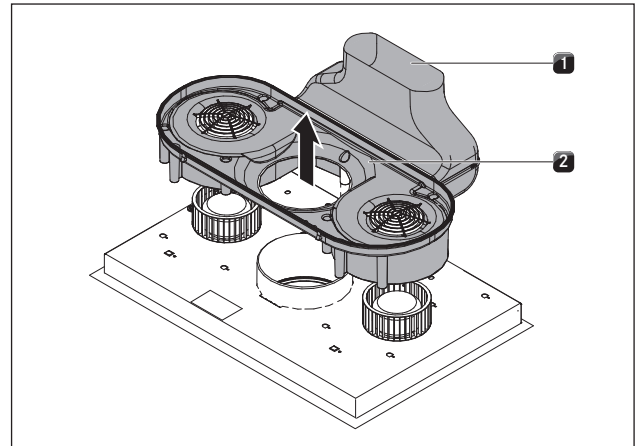

Fig. 6.27 Removing the air guiding housing

[1] Exhaust air arc  
[2] Air guiding housing

- Remove the air guiding housing [2] with exhaust air arc [1] upwards.

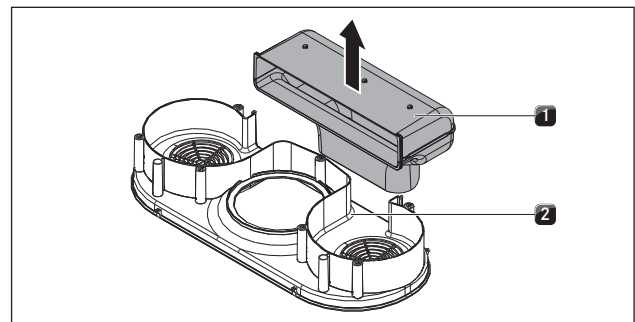

Fig. 6.28 Removing the exhaust air arc

[1] Exhaust air arc  
[2] Air guiding housing

- Move the exhaust air arc [1] from the air guiding housing [2] upwards.

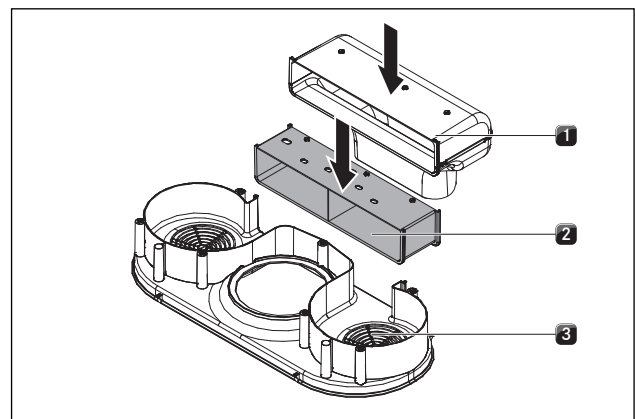

Fig. 6.29 Inserting the extension for exhaust air duct

[1] Exhaust air arc  
[2] Extension for exhaust air duct  
[3] Air guiding housing

- ▶ Insert the extension for the exhaust air duct [2] into the groove of the air guiding housing [3].
- ▶ Insert the exhaust air arc [1] into the groove of the extension for the exhaust air duct [2].

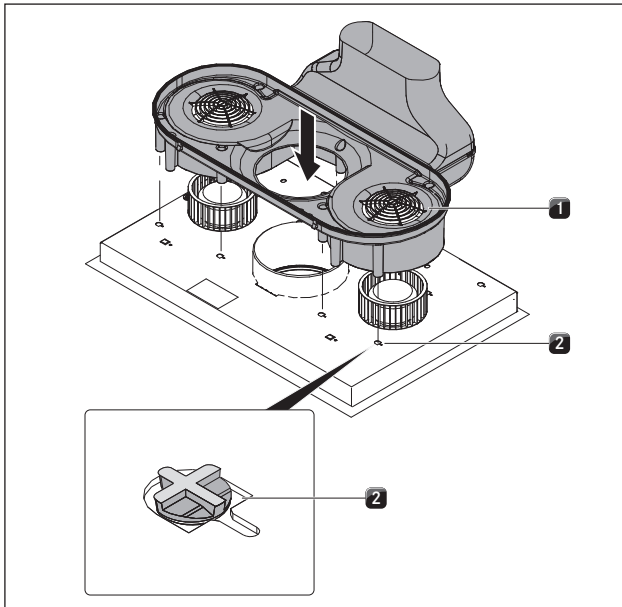

Fig. 6.30 Inserting the airflow assembly on the cooktop base

- [1] Airflow assembly
- [2] Openings

- ▶ Position the airflow assembly [1] at the cooktop base in such a way that all retaining hooks are in the openings [2].

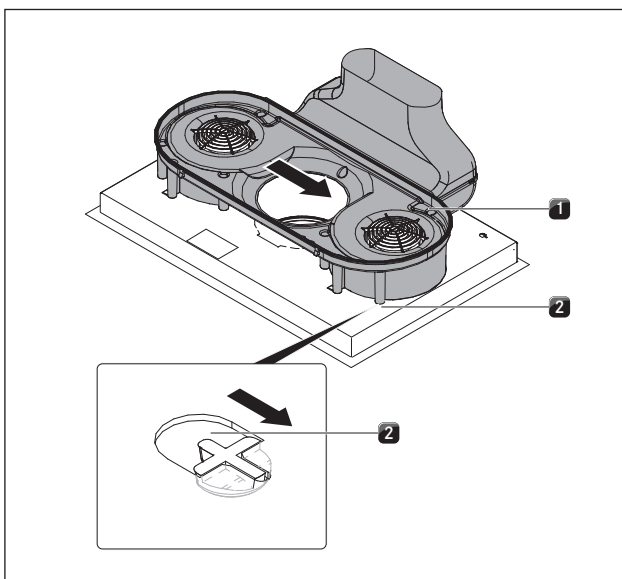

Fig. 6.31 Engaging the airflow assembly

- [1] Airflow assembly
- [2] Openings

- ▶ Now move the airflow assembly [1] to the right until it engages fully into the slot of the opening [2].

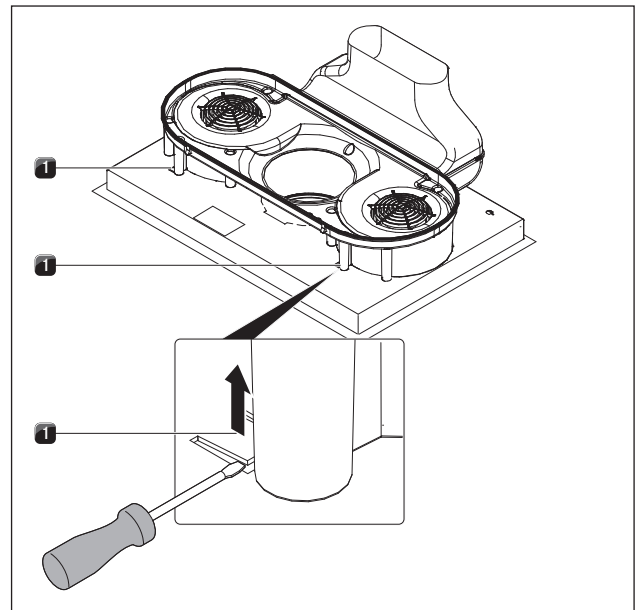

Fig. 6.32 Position lock

- [1] Shackles for transport and position lock

- ▶ Press the two shackles [1] for the position lock upwards.
- ▶ Lift the cooktop with integrated cooktop extractor.
- ▶ Turn the glass ceramic panel upwards.

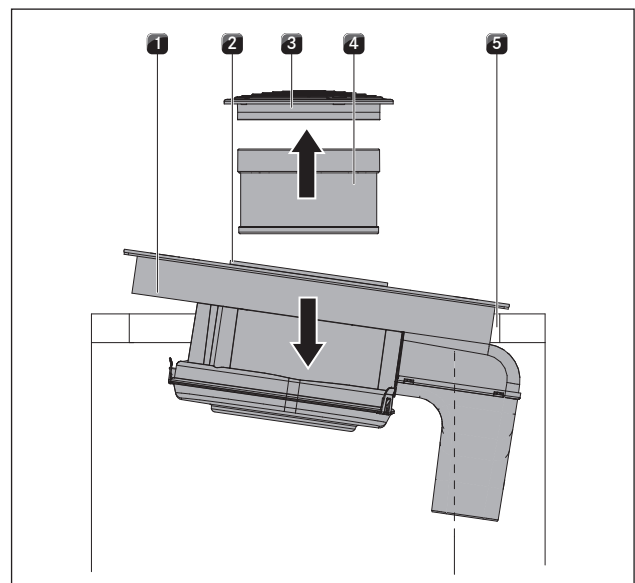

Fig. 6.33 Inserting the cooktop

- [1] Cooktop
- [2] Suction opening
- [3] Air inlet nozzle
- [4] Stainless steel grease filter
- [5] Worktop cut-out

- ▶ Use the suction opening [2] as a handle during insertion.
- ▶ Reach into the suction opening [2].
- ▶ Insert the cooktop centrally into the provided worktop cut-out [5].
- ▶ Align the cooktop precisely.

**For surface installation**

- ▶ Make sure that the sealing tape is resting on the worktop.

**For flush installation**

- ▶ Make sure that the sealing tape of the cooktop is sealed well all the way round.

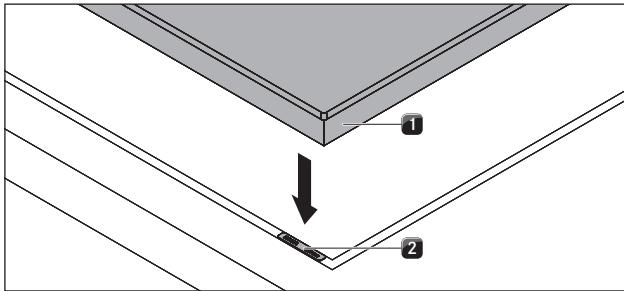

Fig. 6.34 Height adjustment plates

- [1] Cooktop  
[2] Height adjustment plates

- ▶ If necessary insert height adjustment plates [2].

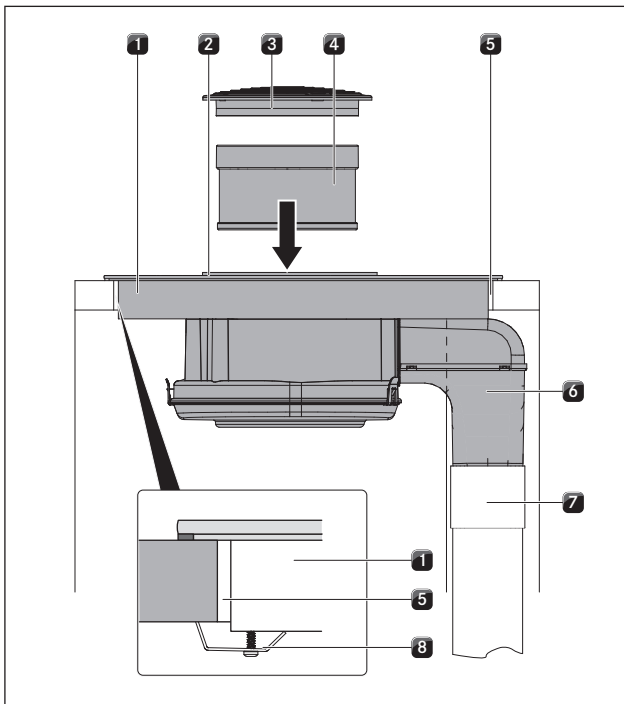

Fig. 6.35 Connecting the exhaust air duct + secure

- [1] Cooktop  
[2] Suction opening  
[3] Air inlet nozzle  
[4] Stainless steel grease filter  
[5] Worktop cut-out  
[6] Exhaust air arc  
[7] Exhaust air duct  
[8] Mounting bracket

- ▶ Connect the exhaust air duct [7] installed on-site to the exhaust air arc [6].
- ▶ Seal the duct connection so that it is airtight using adhesive sealing tape UDB1.
- ▶ Fasten the cooktop using the mounting brackets [8] at the worktop.
- ▶ Afterwards, insert the stainless steel grease filter [4] and air inlet nozzle [3].
- ▶ Seal the surrounding gap with a black heat-resistant silicone sealing compound.

## 6.8 Establishing the power connection

- ▶ Observe all safety and warning information (see Safety chapter).
- ▶ Observe all national and regional laws and regulations as well as the supplementary regulations of the local utility companies.

**INFO** The power connection must only be implemented by a certified engineer. He/she also assumes responsibility for the proper installation and commissioning.

**INFO** Connection via plug-in contacts, e.g. plugs with earthing contacts, are not allowed.

- ▶ Switch off the main switch/automatic circuit breaker before connecting the cooktop.
- ▶ Protect the main switch/automatic circuit breaker from being switched on without permission.
- ▶ Make sure the device is not energised.
- ▶ Only connect the cooktop using a permanent connection to a type H 05 VV-F power supply line with appropriate minimum cross section (s. Tab. Fuse protection and minimum cross section).

Connection	Fuse protection	Minimum cross-section
Three-phase-connection	3 x 16 A	2.5 mm <sup>2</sup>
Two-phase-connection	2 x 16 A	2.5 mm <sup>2</sup>
One-phase-connection	1 x 32 A	4 mm <sup>2</sup>

Tab. 6.2 Fuse protection and minimum cross section

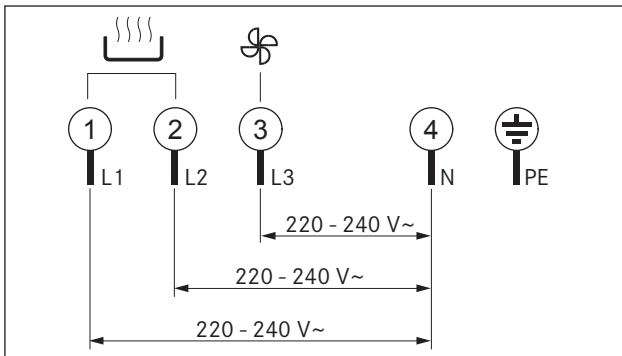

Fig. 6.36 Connection diagram 3-phase connection

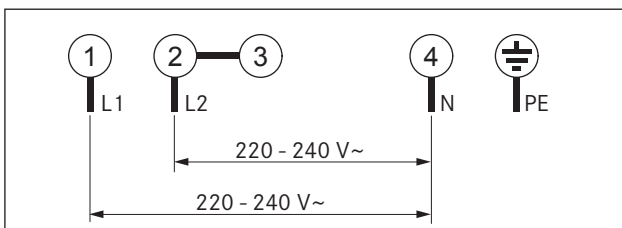

Fig. 6.37 Connection diagram 2-phase connection

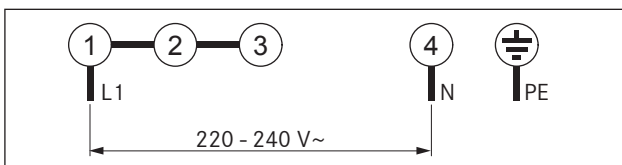

Fig. 6.38 Connection diagram 1-phase connection

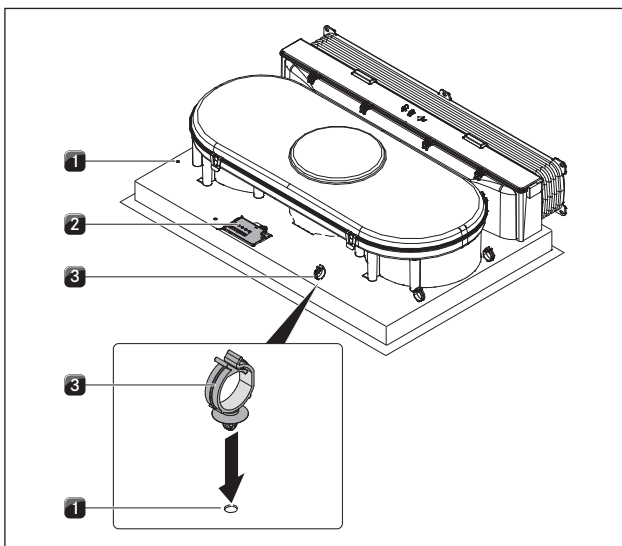

Fig. 6.39 Electrical connections of the cooktop

- [1] Bore holes
- [2] Power supply
- [3] Cable mounting clip

- ▶ Based on the relevant connection diagram (see Figs. Connection diagram), connect the power supply line to the power connection [2] on the cooktop with integrated cooktop extractor.

- ▶ For one- or two-phase-connections install the relevant contacts with the BKAS connector clip (included in the scope of delivery).
- ▶ Fasten the cable mounting clips [3] in the designated bore holes (1) either on the left or right hand side for the cable routing to the rear.
- ▶ Make sure that the cable is not clamped or damaged and cannot touch any hot parts of the cooktop.
- ▶ Verify that the installation was done correctly.
- ▶ Switch on the main switch/automatic circuit breaker.
- ▶ Put the cooktop extractor into operation (see the Operation chapter).
- ▶ Check all the functions are working correctly.

## 6.9 Handover to user

Once installation is done:

- ▶ Explain the important functions to the user.
- ▶ Explain all safety-relevant aspects of operation and handling to the user.
- ▶ Provide the user with the accessories and operating and installation instructions to be kept in a safe place.



## 7 Operation

- ▶ Observe all safety and warning information during operation (see Safety chapter).

---

**INFO** The integrated cooktop extractor must not be used with other cooktops.

---

**INFO** The cooktop may only be operated when the stainless steel grease filter and air inlet nozzle are installed.

---

### 7.1 Switch on/off the cooktop and cooking zone

#### Switching on

- ▶ Press **⏻** to switch on the cooktop.  
The power level **5** is shown in the cooking zone indicators.

#### Switching off

- ▶ Press **⏻** to switch off the cooktop.
- ▶ Pay attention to the residual heat indicator (see Chapter 6.1.7).

#### 7.1.1 Switching on the cooking zone

- ▶ Press the cooking zone button (e.g. **⏻**) for the required cooking zone.  
The **5** in the cooking zone indicator lights up more brightly.

#### 7.1.2 Adjusting the power level

---

**INFO** The configured power level lights up more brightly and automatically darkens again after a few seconds.

---

- ▶ Press **+** to adjust the power level **5**.
- or
- ▶ Press **-** to adjust the power level **9**.

#### 7.1.3 Changing the power level

- ▶ Press the cooking zone button (e.g. **⏻**) of the desired cooking zone. The cooking zone indicator lights up more brightly.
- ▶ Press **+** or **-** until the required power level is shown in the cooking zone indicator.

#### 7.1.4 Switching on the power setting

---

**INFO** The front left-hand cooking zone is equipped with a performance-boosting power level.

---

- ▶ Press the cooking zone button **⏻**.
- ▶ Continue pressing the **+** until the power level **9** is displayed in the cooking zone indicator.

- ▶ Press **+** again. The power level **P** is shown in the cooking zone indicator.  
After 30 minutes, the cooking zone is automatically switched to power level **9**.
- ▶ If one cooking zone is operated with the **P** power setting, then the operation of the second cooking zone on this side is possible at a maximum of power level **5**.
- ▶ If power level **5** is increased, the **P** power setting is switched off.

#### 7.1.5 Switching the power setting off early

- ▶ Press the cooking zone button **⏻**. The indicator will appear brighter.
- ▶ Continue pressing **-** until the lower power level you want is displayed in the cooking zone indicator.

#### 7.1.6 Switching off the cooking zone

- ▶ Press the cooking zone button (e.g. **⏻**) of the desired cooking zone.
- ▶ Continue pressing **+** or **-** until the cooking zone indicator indicates the power level **5**.  
A **5** appears in the display for a few seconds.

#### 7.1.7 Pay attention to the residual heat display

After switching it off, the cooking zone remains hot. **H** is displayed in the cooking zone indicator (residual heat indicator). This cooking zone indicator will also go out after sufficient time is left to cool down (temperature < 60 °C).

---

**INFO** While a **H** is indicated in the cooking zone indicator (residual heat display), do not touch the cooking zone and do not place any heat-sensitive objects on top of it. Risk of burns and fire!

---

- ▶ Pay attention to the residual heat indicator.
- ▶ Make sure the hot hobs are not touched and no objects are placed on it.

#### 7.1.8 Using the automatic pre-cook valve

---

**INFO** When the automatic pre-cook valve is enabled, the cooking zone will heat up automatically at the highest level (heating impulse) before switching back to the set power level (continuous cooking level). The heating time depends on the continuous cooking level that is set (see Table 6.1).

---







**INFO** For high continuous cooking levels, only relatively low heating times are needed. Usually, when using these settings, empty cookware is heated up in preparation for frying.

---

Power level	1	2	3	4	5	6	7	8
Heating time (minutes:seconds)	1:00	3:00	4:48	6:30	8:30	2:30	3:30	4:30



Tab. 7.1 Heating time per power level

### Switching on the automatic pre-cook valve

- ▶ Press the cooking zone button (e.g. ) for the required cooking zone.  
The cooking zone indicator lights up more brightly.
- ▶ Continue pressing the  until power level 9 is displayed in the cooking zone indicator.
- ▶ Press  again.  
An  appears in the display.
- ▶ Press  within 5 seconds until the required continuous cooking level appears in the cooking zone indicator.  
An  and the configured continuous cooking level appears in the display for the duration of the active automatic pre-cook valve.

**INFO** After the heating time has passed, the power will be reduced to the selected continuous cooking level.

### Switching the automatic pre-cook valve off early

- ▶ Press the cooking zone button (e.g. ) of the desired cooking zone. The indicator will appear brighter.
  - ▶ Continue pressing  until the power level you want is displayed.
- or
- ▶ Continue pressing  until power level 9 is displayed in the cooking zone indicator.  
The set power level lights up more brightly in the cooking zone indicator and automatically gets darker after a few seconds. The automatic pre-cook valve is now no longer active.

## 7.1.9 Using the timer function



### Prerequisite

- The cooktop must be switched on.

You can use 2 timer functions:

- Short time (egg timer) (the cooking zone is not automatically switched off)
- Automatic cut-off (timer) (for automatic cutting off of cooking zone)

You can set a time range of between 1 and 99 minutes for both timer functions.





**INFO** If you first press , 1 minute is pre-set as the start time.  
If you first press , 30 minutes are pre-set as the start time.

**INFO** After the pre-set time has passed in the timer display,  will be shown for a few seconds.  
A signal tone will sound for a few seconds.

Switching off the timer signal tone

- ▶ Press any sensor button on the operating panel to end the signal tone prematurely.

### Setting the short time (egg timer)

- ▶ Press  and  simultaneously.  
In the timer display  will appear for a few seconds.
- ▶ Press  or  to set the required time.





### Setting the automatic cut-off (timer)

You can set an automatic cut-off for every cooking zone.





**INFO** The cooking zone control light indicates whether the automatic switch off is activated. The cooking zone indicator light lights up until the cooking zone is switched off after the pre-set time has passed.

**INFO** If several cooking zones are activated with an automatic cut-off, the cooking zone indicator light with the lowest timer value will light up provided that a cooking zone was not selected.





### Prerequisite

- A cooking zone has been selected.
- A power level was set.
- ▶ Press  and  simultaneously.  
In the timer display  will appear for a few seconds.
- ▶ Press  or  to set the required time.  
After the last input, the set time will be displayed in the timer display for a few seconds.

### Changing the timer settings

- ▶ Press the cooking zone button for the cooking zone (e.g. ) for which you wish to change the automatic cut-off.
- ▶ Press  and  simultaneously.  
In the timer display, the set time is displayed and the cooking zone indicator light flashes.
- ▶ Press  or  to set the required time.

### If several timers are active

- ▶ Continue pressing  and  simultaneously until the indicator light for the desired cooking zone starts flashing.  
The cooking zone control lights are controlled in a clockwise order for which a timer was activated, beginning with the short time (egg timer).
- ▶ Press  or  to change the set time.

### Switching the timer off early

- ▶ Press the cooking zone button of the cooking zone for which you wish to switch off the timer.

- ▶ Press **+** and **-** simultaneously.  
In the timer display, the set time is displayed and the cooking zone indicator light flashes.
- ▶ Press **-** until the timer display shows **00**.

### 7.1.10 Activating/deactivating the child safety lock

#### Activating the child safety lock

**INFO** If a cooking zone indicator alternately shows **L** and **H**, this means the cooking zone is still hot.

##### Prerequisites:

- The cooktop is switched on.
- All cooking zones are switched off.
- ▶ Within 10 seconds of switching it on, press sensor buttons **+** and **-** simultaneously before pressing the sensor button **+** one more time.  
An **L** will appear in all cooking zone indicators.  
The child safety lock is activated.

#### Deactivating the child safety lock for a cooking session

**INFO** If a cooking zone indicator alternately shows **0** and **H**, this means the cooking zone is still hot.

- ▶ Press the sensor buttons **+** and **-** simultaneously.  
The power level **0** will be displayed in all cooking zone indicators and the cooking zone indicator lights will flash.
- The power level you require can now be set for each cooking zone.
- After the cooktop has been switched off, the child safety lock is activated again.

#### Deactivating the child safety lock

**INFO** If a cooking zone indicator alternately shows **0** and **H**, this means the cooking zone is still hot.

##### Prerequisites:

- The cooktop is switched on.
- ▶ Press the sensor buttons **+** and **-** simultaneously and then **-** again.  
All cooking zone indicators will show power level **0**.  
The child safety lock is deactivated.

## 7.2 Operating the cooktop extractor

##### Prerequisite:

- The cooktop with integrated cooktop extractor is switched on.

##### Recommendations for an efficient vapour extraction:

- ▶ Make sure to always use a lid for pots that are particularly high. This ensures effective vapour extraction. It also reduces power consumption.
- ▶ Only operate the cooktop extractor at the minimum power level required for an effective vapour extraction. This way, you can improve the performance of the odour filters during air circulation operation.
- ▶ Only operate the hob at the minimum power level required for cooking. This reduces the cooking vapours and power consumption.
- ▶ Avoid strong drafts.

### 7.2.1 Switching on the cooktop extractor

- ▶ Press **+** or **+** to switch on the cooktop extractor.  
**0** is shown in the fan level indicator. If no further input is made, the cooktop extractor will switch off automatically a few seconds afterwards.

### 7.2.2 Setting the fan level

- ▶ Press **+** to increase the fan level.  
The following fan level sequence is run through:

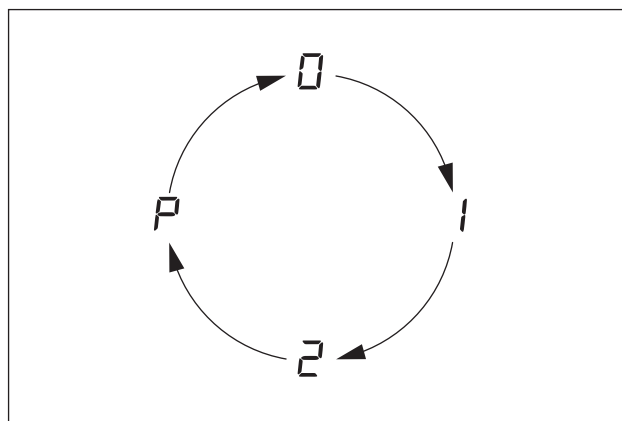

Fig. 7.1 Fan level sequence **+**

- ▶ Press **+** to reduce the fan level. The following fan level sequence is run through:

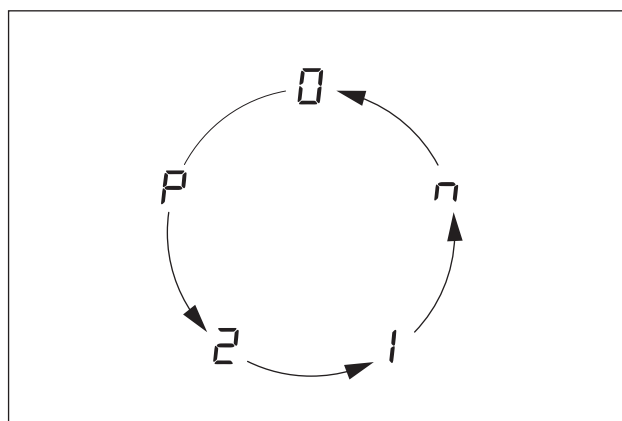





Fig. 7.2 Fan level sequence **+**

### 7.2.3 Switching on the delayed automatic after-run



- ▶ Continue pressing  until fan level  $n$  for delayed automatic after-run is shown.  
The fan runs in level 1 and switches off automatically after 10 minutes.

### 7.2.4

Switching off the cooktop extractor

- ▶ Press  and  simultaneously until the fan level indicator  is displayed,

or



- ▶ press  or  several times until the fan level indicator  is displayed.

When the fan level indicator displays , the cooktop extractor is switched off automatically after a few seconds.

## 7.3 Pay attention to the filter service display

If the fan level indicator displays  $F$  (F = filter service indicator), this means the activated charcoal filter is used up (for recirculated air only) and the stainless steel grease filter needs an overhaul.

If you do not wish to do the filter change yet, e.g. if you only cook occasionally:





- ▶ Press  or  to go into the normal operating mode.  
 is shown in the fan level indicator.

### Changing the filter

- ▶ Switch off the cooktop with integrated cooktop extractor.
- ▶ Observe all warnings that are described in the Cleaning chapter.
- ▶ Replace the activated charcoal filter.
- ▶ Clean the stainless steel grease filter, the air inlet nozzle, the air guiding housing and the housing base.

### Resetting the filter service display

If the activated charcoal filter was replaced (only for recirculated air) and the stainless steel grease filter was cleaned, it will be necessary to reset the filter service display.

- ▶ Switch on the cooktop with integrated cooktop extractor.  
The fan level indicator shows an  $F_$
- ▶ Press  and  simultaneously for at least three seconds until a  flashes in the air level indicator.  
After a few seconds,  will be displayed permanently.  
The filter service display has been reset.

## 7.4 Saving energy

- ▶ Follow all of the energy-saving tips to use the cooktop with integrated cooktop extractor in an energy-efficient manner.
- ▶ When purchasing cookware, pay attention to the diameter of the base. Usually the upper diameter of the pot is given. The diameter of the base is often smaller.
- ▶ Use pressure cookers. Due to the closed cooking chamber and the overpressure, pressure cookers save the most time and energy. The short cooking time helps preserve vitamins.
- ▶ Make sure there is sufficient liquid in the pressure cooker. An empty pot which is still being heated can lead to overheating. The cooking zone and the pot may be damaged by overheating.
- ▶ If possible, always close cookware using a suitable lid.
- ▶ Choose a suitable size of cookware commensurate with the amount of food you are cooking. A big pot that is barely filled requires a lot of energy.

## 8 Cleaning and maintenance

- ▶ Observe all safety and warning information (see Safety chapter).
- ▶ Follow the enclosed manufacturer's information.
- ▶ Make sure that the cooktop and cooktop extractor have been switched off completely and have cooled down prior to the planned cleaning and maintenance work to prevent injury (see the Operation chapter).
- Regular cleaning ensures the longevity of the product and optimal functioning.
- ▶ Adhere to the following cleaning and maintenance cycles:

Component	Cleaning cycle
Operating panel	Immediately after every soiling
Cooktop	Immediately after every soiling every week thoroughly with standard commercially available glass ceramic cleaners
Cooktop extractor	Weekly
Air inlet nozzle and stainless steel grease filter	After every time you prepare very greasy foods; at least weekly, when the fan level indicator = $F$ by hand or in the dishwashing machine (at a max. 65 °C); Only clean the stainless steel surfaces in the polishing direction!
Air guiding housing	Clean every 6 months or when replacing the activated charcoal filter
Activated charcoal filter (only for recirculated air)	Replace after the build-up of odour, when the extraction power has diminished or the fan level indicator shows $F$

Tab. 8.1 Cleaning cycles

### 8.1 Cleaning agents

**INFO** Due to the use of aggressive cleaning agents and abrasion caused by the pot bases the surface will become damaged and dark stains will occur.

You need a special glass ceramic panel scraper and suitable cleaning agents to clean the cooktop.

- ▶ Never use steam cleaners, abrasive sponges, scouring pads, or chemically aggressive cleaning agents (e.g. baking oven spray).
- ▶ Make sure that the cleaning agent does not contain any sand, soda, acids or chloride.

#### For air inlet nozzle and grease filter

- ▶ Do not use any aggressive, acidic or alkaline cleaning agents.

### 8.2 Maintaining the cooktop

- ▶ Do not use the cooktop as a worktop or shelf.
- ▶ Do not push or pull cookware across the cooktop.
- ▶ Always lift pots and pans.
- ▶ Keep the cooktop clean.
- ▶ Remove any kind of soiling immediately.
- ▶ Only use cookware which is suitable for glass ceramic panels (see the Device description chapter)

### 8.3 Cleaning the cooktop

**INFO** When the cooktop extractor is switched on, the air inlet nozzle is installed to ensure that no small and light objects, such as cleaning wipes made of fabrics or paper are sucked in.

- ▶ Make sure that the cooktop is switched off (see Operating chapter).
- ▶ Wait until all cooking zones are cold.
- ▶ Remove all coarse soiling and food residues from the cooktop with a glass ceramic scraper.
- ▶ Apply the cleaning agent onto the cold cooktop.
- ▶ Rub the cleaning agent with a paper towel or a clean cloth.
- ▶ Wipe off the cooktop while wet.
- ▶ Rub the cooktop dry with a clean cloth.

#### When the cooktop is hot:

- ▶ Immediately remove molten residues of plastic, aluminium film, sugar or foods containing sugar with a glass ceramic scraper from the hot cooking zone to prevent burning them in.

#### Special soiling

- ▶ Heavy soiling and stains (limescale stains, pearly shimmering stains) are best to be removed if the cooktop is still warm.
- ▶ Soften dried dirt residues using a damp cloth.
- ▶ Remove dirt residues with the glass ceramic scraper.
- ▶ Always remove grains, crumbs or the like which fall onto the cooktop during general cooking work right away to prevent the surface from being scratched.

Coloured changes and shiny surfaces are not cooktop damage. They do not impact on the function of the cooktop and the stability of the glass ceramic.

Discolourations to the cooktop arise from residues which are not removed and have been burnt in.

Glossy spots are caused by the abrasion of the pot base, especially when using cooking utensils with aluminium bases, or by unsuitable cleaning agents. They are very hard to remove.

## 8.4 Cleaning the cooktop extractor

The air inlet nozzle and the stainless steel grease filter absorb the greasy components of the kitchen vapour.

- ▶ Make sure that the cooktop and cooktop extractor are switched off (see Operating chapter).
- ▶ Wait until the fan display is 0.
- ▶ Clean the cooktop extractor in accordance with the cleaning cycles (see Tab. 7.1).
- ▶ Clean the surfaces of the exhaust air system using a soft damp cloth, detergent or a mild window cleaning agent.
- ▶ Soften dried-on dirt residues using a damp cloth (do not scratch!).

### 8.4.1 Removing the air inlet nozzle and stainless steel grease filter

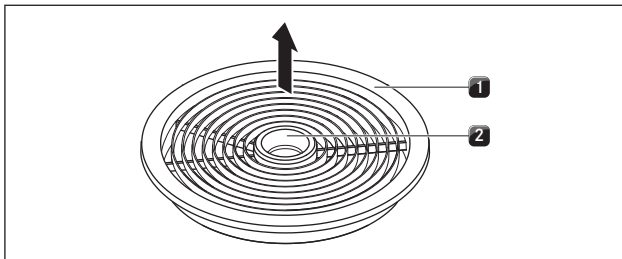

Fig. 8.1 Removing the air inlet nozzle

- [1] Air inlet nozzle
- [2] Access opening

**Prerequisite:** The fan level indicator indicates 0.

- ▶ Reach into the access opening [2] with your hand.
- ▶ Remove the air inlet nozzle [1] out upwards.

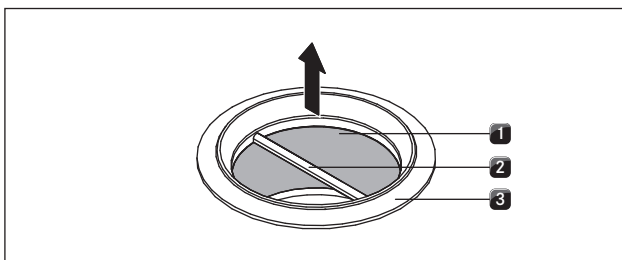

Fig. 8.2 Removing the stainless steel grease filter

- [1] Stainless steel grease filter
- [2] Handle
- [3] Suction opening

- ▶ Grab the stainless steel grease filter using the handle [2].
- ▶ Pull the stainless steel grease filter [1] out of the suction opening [3] upwards.

### 8.4.2 Cleaning the air inlet nozzle and stainless steel grease filter

**INFO** Clean the stainless steel surfaces in the polishing direction only.

**INFO** If the stainless steel grease filter can no longer be cleaned completely, this means the stainless steel grease filter will need to be replaced.

#### Manual cleaning

- ▶ Use a degreasing cleaning agent.
- ▶ Rinse the inlet nozzle and stainless steel grease filter with hot water.
- ▶ Use a soft brush to clean the inlet nozzle and stainless steel grease filter.
- ▶ After cleaning, rinse the inlet nozzle and stainless steel grease filter well.

#### Cleaning in the dishwasher

- ▶ Rinse the air inlet nozzle and the stainless steel grease filter with a rinsing program at a maximum of 65 °C.

### 8.4.3 Installing stainless steel grease filter and air inlet nozzle

- ▶ Grab the stainless steel grease filter using the handle [2] (Fig. 7.2)
- ▶ Insert the stainless steel grease filter [1] into the suction opening.
- ▶ Make sure that the stainless steel grease filter rests against the bottom housing base. A lock is not needed and is not provided.
- ▶ Reach into the access opening [2] of the inlet nozzle with your hand (Fig. 7.1).
- ▶ Insert the air inlet nozzle (Fig. 7.1; [1]) centrally into the suction opening.
- ▶ Press the air inlet nozzle upwards until it engages.

## 8.5 Cleaning the air guiding housing

Greasy deposits and limescale residues from the cooking vapour can accumulate on the surface of the air guiding housing. Regular, thorough cleaning (see Table 7.1) is thus necessary.

The air guiding housing is on the underside of the cooktop in the floor unit.

### 8.5.1 Opening the air guiding housing

- ▶ Make sure that the cooktop and cooktop extractor are switched off (see Operating chapter).
- ▶ Wait until the fan display is 0.



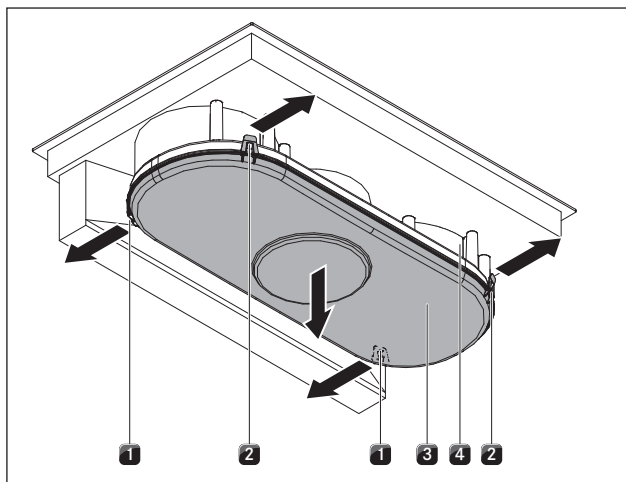

Fig. 8.3 Opening the air guiding housing

- [1] Rear locks
- [2] Front locks
- [3] Housing base
- [4] Air guiding housing

- ▶ Hold the housing base with one hand [3].
- ▶ Open both locks on the rear [1].
- ▶ Open both front locks [2].
- ▶ Remove the housing base [3].
- ▶ Clean the air guiding housing [4] and the housing base [3] with a mild cleaning agent.

### 8.5.2 Closing the air guiding housing

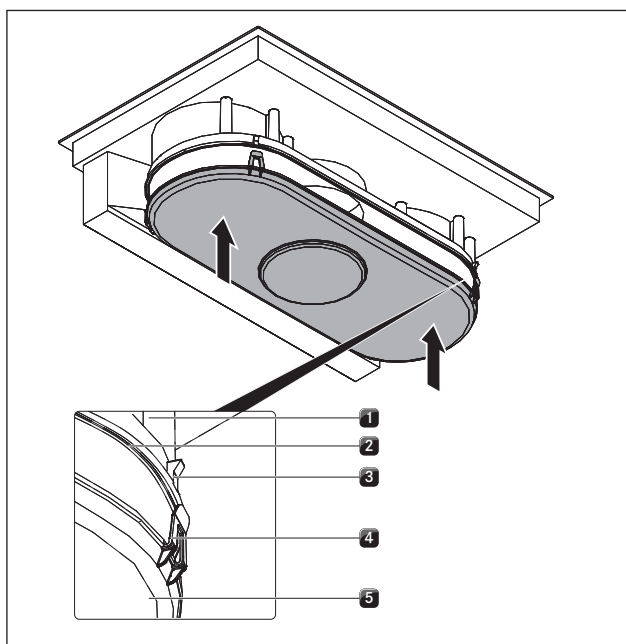

Fig. 8.4 Closing the air guiding housing

- [1] Air guiding housing
- [2] Sealing groove
- [3] Hooks
- [4] Locking stop
- [5] Housing base

- ▶ Using both hands, position the housing base [5] so that the position of the locking straps [4] on the housing base match the position of the hooks [3] on the housing.
- ▶ Insert the housing base at the sealing groove [2] of the air guiding housing [1].
- ▶ Press the housing base [5] upwards until the 4 locks (2 front, 2 rear) engage into the hooks [3].
- ▶ Check that all 4 locking straps [4] have correctly engaged.

## 8.6 Replacing the activated charcoal filter

Two activated charcoal filters are used only when the cooktop extractor is being operated in recirculated air mode. The activated charcoal filter binds odorous materials which arise during cooking.

**INFO** The activated charcoal filters must be replaced when the fan level indicator indicates  $F$  (filter service display). BAKF activated charcoal filters can be purchased from your specialist. You can also contact BORA on its homepage <http://www.bora.com>.

- ▶ Make sure that the cooktop and cooktop extractor are switched off (see Chapter 6.1).
- ▶ Wait until the fan display is  $\square$ .

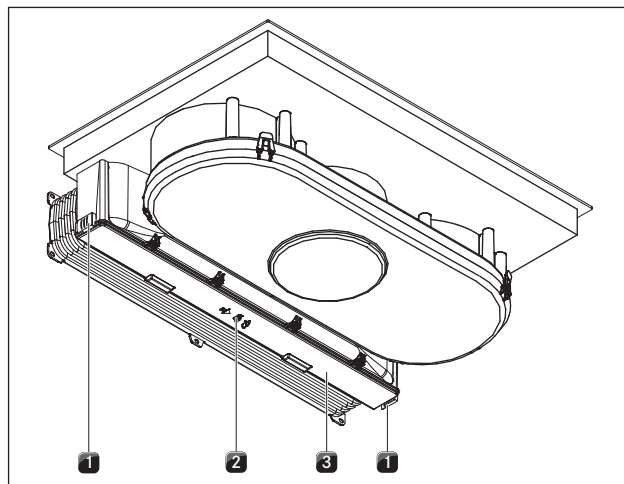

Fig. 8.5 Releasing the activated carbon filter housing lid

- [1] Outer locks
- [2] Middle lock
- [3] Activated carbon filter housing cover



### Removing the activated carbon filter

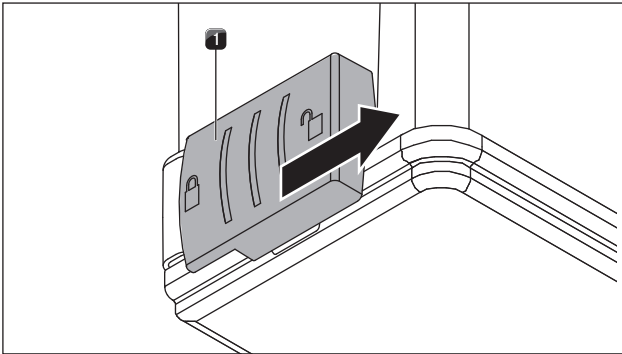

Fig. 8.6 Opening the outer locks

[1] Outer lock

- ▶ Open the two outer locks [1].

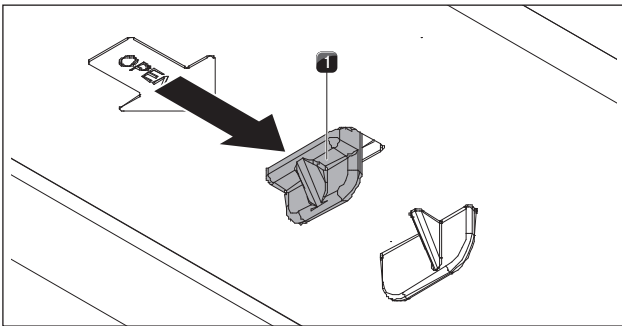

Fig. 8.7 Opening the middle locks

[1] Middle lock

- ▶ Open the middle lock [1].
- ▶ Fold down the housing cover until it engages.

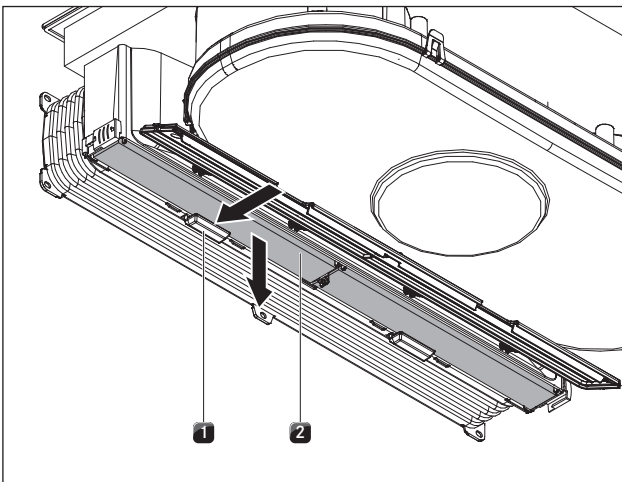

Fig. 8.8 Removing the activated charcoal filter

[1] Filter retainer  
[2] Activated charcoal filter

- ▶ Hold the activated charcoal filter with one hand [2].
- ▶ Push the filter retainer [1] backwards.

- ▶ Pull the activated charcoal filter down and out.
- ▶ Dispose of the used activated charcoal filter in household waste.

### Inserting the activated charcoal filter

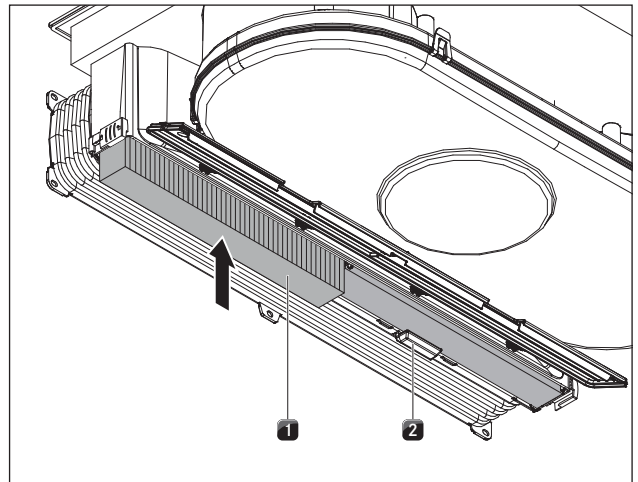

Fig. 8.9 Inserting the activated charcoal filter

[1] Activated charcoal filter  
[2] Filter retainer

- ▶ Position the new activated charcoal filter [1] so that the arrow points to the rear and is visible from below.
- ▶ Slide the activated charcoal filter into the housing.
- ▶ Push the activated charcoal filter upwards until the filter retainer [2] engages.

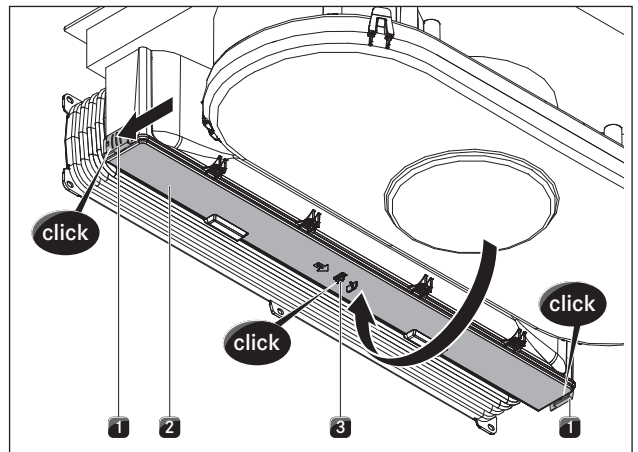

Fig. 8.10 Closing the activated charcoal filter housing cover

[1] Outer locks  
[2] Activated charcoal filter housing cover  
[3] Middle lock

- ▶ Fold up the activated charcoal filter housing cover [2].
- ▶ Press the activated charcoal filter housing cover in the centre until the middle lock [3] engages.
- ▶ Press the activated charcoal filter housing cover on the sides and close the outer locks [1] until they engage.

## 9 Troubleshooting

► Observe all safety and warning information (see Safety chapter).

Operating situation	Cause	Remedy
The cooktop or the fan cannot be switched on.	The fuse or the automatic circuit breaker of the electrical installation of the apartment and/or house is defective.	Change the fuse. Switch the circuit breaker back on.
	The fuse or the automatic circuit breaker trips several times.	Call the BORA Service Team.
	The power supply is disconnected.	Have a specialist electrician inspect the power supply.
Odours and vapours arise when the new cooktop is put into operation.	This is normal on brand-new appliances.	Wait a few operating hours. Contact the Service Team if the odour persists.
L is displayed in the cooking zone indicator.	The child safety lock is activated.	Switch off the child safety lock (see the Operation chapter).
A cooking zone or the entire cooktop switches off automatically.	The operating time of a cooking zone has been exceeded.	Put the cooking zone back into operation (see Operation chapter).
E is displayed in the fan level indicator.	One or more sensor buttons are covered, e. g. due to finger contact or by objects placed on them.	Clean the control panel or remove objects (see Device description chapter)
Er03 is shown across all 4 cooking zone indicators, and the cooktop switches off during operation.		
E is displayed in the cooking zone indicator.	An error has occurred in the electronic system.	Interrupt the power supply for approx. 1 minute. If the problem persists after reconnecting the power supply, take a note of the error number and contact the BORA Service Team.
F is displayed in the fan level indicator.	The period of use of the filters has been exceeded.	Replace the activated charcoal filter (for recirculated air only) and clean the stainless steel grease filter thoroughly. When there is heavy contamination, we recommend you replace the stainless steel grease filter (see Cleaning and Maintenance chapter).
The extraction rate of the cooktop extractor has decreased.	The stainless steel grease filter is heavily soiled.	Clean or replace the stainless steel grease filter.
	The activated carbon filter is heavily soiled (only for recirculated air).	Replace the activated charcoal filter.
	There is an object in the air guiding housing (e.g. cleaning cloth).	Remove the trapped object.
	The fan is defective or a duct connection has loosened.	Call the BORA Service Team.

Tab. 9.1 Resolving a fault

► In all other instances, call the BORA Service Team (see the Warranty, service and spare parts chapter).

## 10 Decommissioning, disassembly and disposal

- ▶ Observe all safety and warning information (see the Safety section).
- ▶ Follow the enclosed manufacturer's information.

### 10.1 Decommissioning

Decommissioning is understood as final shutdown and disassembly. Following decommissioning, the device can either be installed into other units, sold on privately or disposed of.

---

**INFO** Electricity and gas connections may only be disconnected by qualified specialists.

---

- ▶ To decommission, switch the device off (see Operation section)
- ▶ Disconnect the device from the power supply.

### 10.2 Disassembly

For removal, the device must be accessible for disassembly and disconnected from the power supply. For gas devices, make sure the gas connection is disconnected.

- ▶ Undo the mounting brackets.
- ▶ Remove the silicone joints.
- ▶ Disconnect the device from the extractor duct.
- ▶ Remove the device from the worktop by lifting it upwards.
- ▶ Remove any other accessories.
- ▶ Dispose of the old device and any contaminated accessories as described under "Environmentally-friendly disposal".

### 10.3 Environmentally-friendly disposal

#### Disposal of transport packaging

---

**INFO** The packaging protects the device from damage in transport. The packaging materials have been selected from environmental and disposal perspectives and are therefore recyclable.

---

Returning the packaging to the materials cycle saves resources and reduces waste volumes. Your specialist supplier will take the packaging back.

- ▶ Give the packaging to your specialist supplier or
- ▶ Dispose of the packaging properly in line with local regulations.

#### Disposal of old appliance



Electrical devices marked with this label may not be disposed of in domestic waste at the end of their service life. They must be disposed of at a collection point for the recycling of old electrical or electronic devices. You can find information from your city or district council.

Many electrical and electronic devices still contain valuable materials. But they also contain damaging materials which were necessary for them to function properly and safely. These can damage human health or the environment if disposed of improperly or incorrectly handled.

- ▶ Never put your old appliance in domestic waste.
- ▶ Take the old appliance to a regional collection point for return and recycling electrical and electronic components and other materials.

# 11 Warranty, technical service, spare parts, accessories

- ▶ Observe all safety and warning information (see the Safety section).

## 11.1 Warranty

The warranty period is 2 years.

If you register at [www.mybora.com/registration](http://www.mybora.com/registration), the warranty period is extended to 3 years.

## 11.2 Service

### BORA Service:

see back page of operation and installation instructions



- ▶ If there are faults which you are not able to resolve yourself, please contact your BORA specialist supplier or the BORA Service Team.

The BORA Service Team requires the type designation and the build number of your appliance (FD number). Both pieces of information can be found on the nameplate on the back of the instructions and on the appliance base.

## 11.3 Replacement parts

- ▶ Only use original spare parts for repairs.
- ▶ Repairs may only be carried out by the BORA Service Team.

---

**INFO** Replacement parts can be obtained from your BORA dealer, the BORA online service website at [www.bora.com/service](http://www.bora.com/service) or by calling the service number provided.

---

## 11.4 Accessories

- BFF stainless steel grease filter
- BFIED air inlet nozzle
- All Black BEDAB air inlet nozzle
- UDB25 sealing tape
- BKR760 cooktop frame

### Special BHA accessories:

- BUSU recirculation conversion set
- BLAVH1 exhaust air duct extension

### Special BHU accessories:

- BAKFS activated charcoal filter
- BUSAE exhaust air conversion set

## 12 Notes:







**Nameplate:**  
(please affix)

**Germany:**

**BORA Lüftungstechnik GmbH**  
Rosenheimer Str. 33  
83064 Raubling  
Germany  
T +49 (0) 8035 / 9840-0  
F +49 (0) 8035 / 9840-300  
info@bora.com  
www.bora.com

**Australia - New Zealand:**

**BORA APAC Pty Ltd**  
100 Victoria Road  
Drummoyne NSW 2047  
Australia  
T +61 2 9719 2350  
F +61 2 8076 3514  
info@boraapac.com.au  
www.bora-australia.com.au

**Austria:**

**BORA Vertriebs GmbH & Co KG**  
Innstraße 1  
6342 Niederndorf  
Austria  
T +43 (0) 5373 / 62250-0  
F +43 (0) 5373 / 62250-90  
mail@bora.com  
www.bora.com

**Europe:**

**BORA Holding GmbH**  
Innstraße 1  
6342 Niederndorf  
Austria  
T +43 (0) 5373 / 62250-0  
F +43 (0) 5373 / 62250-90  
mail@bora.com  
www.bora.com

