

**EN** Operating and installation instructions BFIA, BFIU

Surface induction glass ceramic cooktop with  
cooktop extractor

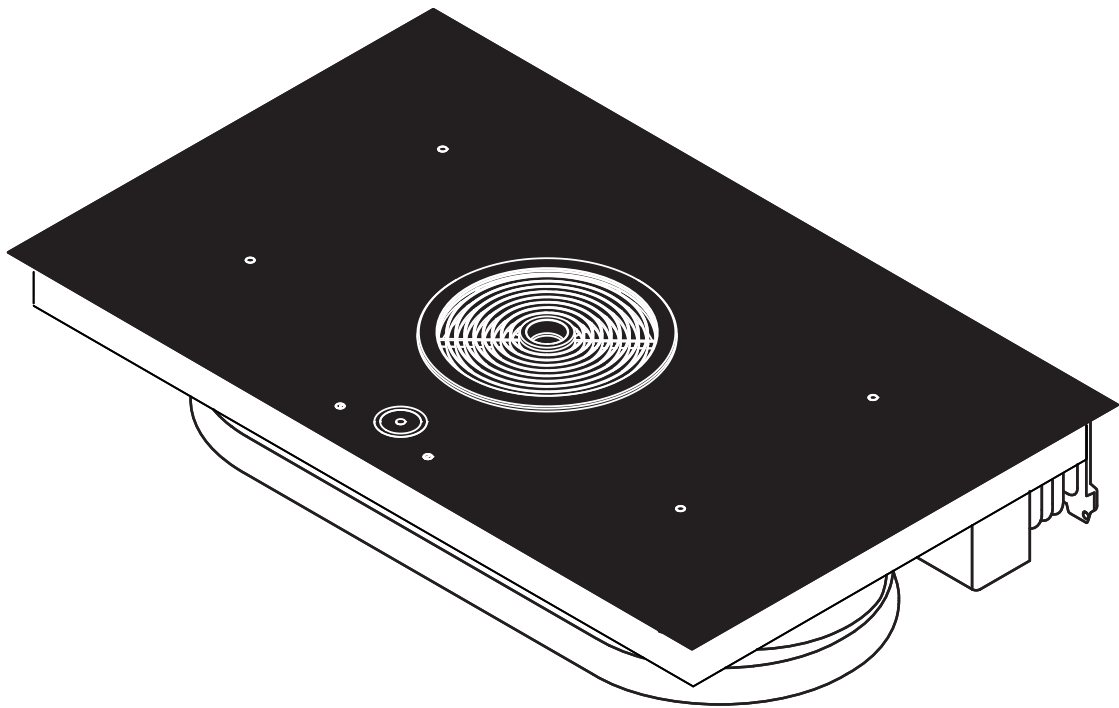

**Operating and installation instructions:**

Original

Translation

**Manufacturer**

**BORA Vertriebs GmbH & Co KG**  
Prof.-Dr.-Anton-Kathrein-Straße 3  
6342 Niederndorf  
Austria

Contact  
T +43 (0) 5373/62250-0  
mail@bora.com  
www.bora.com

The distribution and duplication of this document, as well as the use and disclosure of its contents are prohibited unless expressly authorised.

© BORA Vertriebs GmbH & Co KG

All rights reserved.

# Table of Contents

<b>1</b>	<b>General</b>	<b>4</b>
<b>2</b>	<b>Safety</b>	<b>6</b>
2.1	General safety precautions .....	6
2.2	Safety instructions, operation .....	7
2.3	Safety instructions, assembly.....	9
2.4	Safety instructions, disassembly and disposal ..	10
2.5	Safety instructions, spare parts .....	11
2.6	Use as intended .....	11
<b>3</b>	<b>Technical data</b>	<b>12</b>
<b>4</b>	<b>Energy label</b>	<b>13</b>
<b>5</b>	<b>Device description</b>	<b>14</b>
5.1	Structure .....	14
5.2	Operating panel and operating principle .....	15
5.3	Functional principle of the cooking zone.....	16
5.3.1	Power levels .....	16
5.3.2	Automatic heat up function.....	16
5.3.3	power setting .....	16
5.3.4	Heat retention levels .....	16
5.3.5	Bridging function .....	16
5.3.6	Pause function .....	17
5.3.7	Timer functions .....	17
5.3.8	Pan size recognition .....	17
5.3.9	Suitable cookware.....	17
5.4	Functional principle of the cooktop extractor ...	17
5.4.1	Freely adjustable power control.....	17
5.4.2	Automatic cooktop extractor function.....	17
5.4.3	Power setting .....	18
5.4.4	Automatic after-run .....	18
5.4.5	Filter service display.....	18
5.4.6	Interface communication.....	18
5.5	Safety devices .....	18
5.5.1	Residual heat display.....	18
5.5.2	Safety shut-down .....	18
5.5.3	Cooking zone overheating protection.....	18
5.5.4	Automatic switch-off if the button is pressed and held.....	18
5.5.5	Childproofing feature.....	18
<b>6</b>	<b>Installation</b>	<b>19</b>
6.1	Checking the scope of delivery .....	19
6.2	Tool and aids.....	19
6.3	Assembly instructions .....	19
6.3.1	Safety distances.....	19
6.4	Cut-out dimensions for the cooktop.....	19
6.5	Installing the recirculation version (BFIU).....	21
6.6	Installing the exhaust air version (BFIA) .....	24
6.6.1	Operating the cooktop extractor with a fireplace that depends on the air in the room... 24	24
6.7	Establishing the power connection.....	28
6.8	Device power management (overall power reduction).....	29
6.9	Connect the external switch contact .....	29
6.10	Handover to user.....	31
<b>7</b>	<b>Operation</b>	<b>32</b>
7.1	General operating instructions .....	32
7.2	Operating the cooktop .....	32
7.2.1	Select cooking zone .....	32
7.2.2	Adjusting the power level.....	32
7.2.3	Changing the power level.....	32
7.2.4	Selecting the power setting.....	32
7.2.5	Switching the power setting off early.....	32
7.2.6	Switching off the cooking zone .....	32
7.2.7	Pay attention to the residual heat display.....	32
7.2.8	Pause function .....	33
7.2.9	Bridging function .....	33
7.2.10	Switching on the bridging function.....	33
7.2.11	Switching off the bridging function .....	33
7.2.12	Automatic heat up function .....	33
7.2.13	Switching off the automatic heat up function ...	34
7.2.14	Heat retention level.....	34
7.2.15	Using the timer function.....	34
7.2.16	Switching the signal beep off early .....	34
7.2.17	Setting the short-time timer (egg timer).....	34
7.2.18	Switching off the short-time timer (egg timer) early .....	34
7.2.19	Setting the automatic cut-off .....	34
7.2.20	Switching off the automatic cut-off early .....	34
7.2.21	Changing the timer settings .....	34
7.2.22	Switching the childproofing feature on/off .....	35
7.3	Operating the cooktop extractor .....	35
7.3.1	Selecting a cooktop extractor .....	35
7.3.2	Adjusting the power level .....	35
7.3.3	Changing the power level.....	35
7.3.4	Selecting the power setting.....	35
7.3.5	Automatic cooktop extractor function.....	35
7.3.6	Switching off the automatic cooktop extractor function.....	36
7.3.7	Automatic after-run .....	36
7.3.8	Switching off the automatic after-run early.....	36
7.3.9	Switching off the cooktop extractor .....	36
7.4	Pay attention to the filter service display .....	36
7.5	Saving energy.....	36
<b>8</b>	<b>Cleaning and maintenance</b>	<b>37</b>
8.1	Cleaning agents.....	37
8.2	Maintaining the cooktop .....	37
8.3	Cleaning the cooktop .....	37
8.4	Cleaning the cooktop extractor.....	38
8.4.1	Removing the air inlet nozzle and stainless steel grease filter .....	38
8.4.2	Cleaning the air inlet nozzle and stainless steel grease filter .....	38
8.4.3	Installing stainless steel grease filter and air inlet nozzle .....	38
8.5	Cleaning the air guiding housing .....	38
8.5.1	Opening the air guiding housing.....	38
8.5.2	Closing the air guiding housing .....	39
8.6	Replacing the activated charcoal filter .....	39
<b>9</b>	<b>Troubleshooting</b>	<b>41</b>
<b>10</b>	<b>Decommissioning, disassembly and disposal</b>	<b>42</b>
10.1	Decommissioning.....	42
10.2	Disassembly .....	42
10.3	Disposing of the product in an environmentally friendly way .....	42
<b>11</b>	<b>Warranty, service and spare parts</b>	<b>43</b>
11.1	Warranty.....	43
11.2	Service .....	43
11.3	Spare parts.....	43

# 1 General

## Target group

These operating and assembly instructions are intended for the following target groups:

Target group	Requirements
Users	The Device may be used by children from the age of 8 as well as by people with limited physical, sensory or mental capabilities or a lack of experience and/or knowledge, provided they are supervised, have been instructed in the safe use of the device and have understood the dangers involved. Children must be supervised. All safety and warning information and handling instructions in the operating manual must be followed.
Ambitious DIYers	Ambitious DIYers may carry out all the necessary carpentry and assembly work themselves providing that they have the necessary skills and knowledge. They must not connect the current and gas themselves.
Assembly expert	The assembly expert must carry out all the necessary carpentry and assembly work taking existing regulations into account. The current and gas connections must be approved for the system in use by a certified electrician or gas engineer before use.
Electrical expert	The electrical connection must only be executed by a certified electrician. He/she also assumes responsibility for the proper electrical installation and commissioning.
Expert gas connection	The gas connection must only be implemented by a certified gas engineer. He/she also assumes responsibility for the proper gas installation and commissioning.

Tab. 1.1 Target groups

**INFO** BORA Holding GmbH, BORA Vertriebs GmbH & Co KG, BORA APAC Pty Ltd and BORA Lüftungstechnik GmbH - hereinafter referred to as BORA - shall not assume any liability for damage caused by non-compliance with these documents nor by improper assembly! The electricity and gas connections must be implemented by a certified engineer. Assembly must only take place in compliance with the applicable norms, regulations and laws. All safety and warning information and handling instructions in the operating and assembly instructions must be followed.

## Validity of the operating and assembly instructions

This manual is valid for several versions of the device. For this reason, it is possible that individual features are described in the manual that do not apply to your device.

## Other applicable documents

Additional documents are valid as well as these operating and assembly instructions, and likewise need to be observed.

Please observe all documents included in the scope of delivery.

**INFO** BORA cannot assume any liability for damage caused by non-compliance with these documents!

## Guidelines

These devices meet the following EC guidelines:

2014/30/EC EMC Directive  
 2014/35/EC Low-Voltage Directive  
 2009/125/EC Ecological Design Directive  
 2010/30/EC Energy label Directive  
 2011/65/EC RoHS Directive  
 2012/19/EC WEEE Directive

## Depiction of information

We used standard formatting, numbering, symbols, safety instructions, terms and abbreviations so that you can work quickly and safely when using this manual.

**Instructions** are marked with an arrow.

► Always perform all instructions in the prescribed order. **Enumerations** are indicated with a square bullet point at the start of the line.

■ Enumeration 1  
 ■ Enumeration 2

**INFO** Information notes point to special features that must be taken into account.

## Safety and warning instructions

The safety and warning instructions in this manual are emphasised with symbols and signal words.



Safety and warning instructions are structured as follows:

**WARNING SYMBOL AND SIGNAL WORD!**  
**Type and source of the danger**  
 Results of non-compliance

► Measures to minimise risk

Please note:

- The warning symbol draws your attention to the risk.
- The signal word indicates the severity of that risk.

Warning symbol	Signal word	Risk
	<b>Danger</b>	Indicates an immediate, hazardous situation which causes death or serious injury if not respected.
	<b>Warning</b>	Indicates a potentially hazardous situation which can cause death or serious injury if not respected.
	<b>Caution</b>	Indicates a possible hazardous situation which can cause minor injury if not respected.
–	<b>Caution</b>	Indicates a situation which can cause minor injury if not respected.

Tab. 1.2 Meaning of the warning symbols and signal words

## 2 Safety

### 2.1 General safety precautions

---

**INFO** The product complies with the mandatory safety provisions. The user is responsible for cleaning, care and safe use of the device. Any improper use may lead to personal injury and property damage.

---

- This operating and installation instructions contain important information concerning assembly and operation. It protects you from injury and prevents damage to the product. You can find contact data to get further information and answers to questions about the use of the product on the last page of this operating and installation instructions.
- The term “device” is used to refer to cooktop, cooktop extractor or cooktop with integrated cooktop extractor.
  - ▶ Read this operating and installation instructions in full before you assemble the device and start to use it.
  - ▶ Always keep these operating and installation instructions to hand so it is available when needed.
  - ▶ After selling the device, pass on the operating and installation manual to the new owner.
  - ▶ Carry out all work with great care and attention.
  - ▶ Check the device for visible damage after unpacking.
  - ▶ Do not install a damaged device.
  - ▶ Do not use the device until installation is complete. Only in this way a safe operation can be guaranteed.
  - ▶ Make sure contact with hot cooking surfaces is not possible.
  - ▶ Avoid over-cooking.
  - ▶ Pay attention to the residual heat indicator.
  - ▶ Turn the device off after use.
  - ▶ Do not rely on the pan size recognition.
  - ▶ Keep pets away from the device.

#### Recirculated air mode

---

**INFO** Every time the device is used for cooking, supplementary moisture is released into the room air.

---



---

**INFO** In the recirculated air mode, only a small amount of moisture is removed from the cooking vapours.

---

- ▶ Make sure that the room is sufficiently ventilated to the outside air in the recirculated air mode, e.g. through an open window.
- ▶ Ensure a normal and comfortable indoor climate (45-60% humidity), e.g. through natural ventilation openings or domestic ventilation systems.
- ▶ Set the cooktop extractor to a low setting for about 15 minutes or activate the automatic after-run after every use in the recirculated air mode.

#### Effects on pacemakers, hearing aids and metal implants

---

**INFO** Induction cooktops generate a high-frequency electromagnetic field in the area of the cooking zones. The cooking zones may affect pacemakers, hearing aids or metal implants negatively or disturb their function when in close proximity. A reduced function of the pacemaker is unlikely.

---

- ▶ If in doubt, contact the manufacturer of your medical device or your doctor.

#### When there are children and people with special needs in the house

- This device may be used by children from the age of 8 as well as by persons with limited physical, sensory or mental capabilities or a lack of experience and/or knowledge, provided they are supervised, have been instructed in the safe use of the device and have understood the dangers involved.
- Do not leave children unattended when they are near the device.
- Children must not play with the device.
- Use the child safety lock in order to prevent children from switching on the cooktop or changing the settings when they are unattended.
- ▶ Do not store any objects that could be of interest to children in storage spaces above or behind the device. Otherwise, the children will be tempted to climb onto the device.
- ▶ Keep children and other persons away from the cooking surfaces.

#### Unauthorised modifications

Due to unauthorised modifications

The device can constitute a hazard.

- ▶ Do not make any changes to the device.

### Cleaning and Maintenance

The device must be cleaned at regular intervals. Dirt can lead to damage or odour nuisance.

Remove dirt immediately.

- Any work involving cleaning and user maintenance must not be carried out by children unless they are supervised at all times while doing so.
- ▶ Do not use a steam cleaner for cleaning. Steam can cause a short circuit on live parts and thus lead to property damage (see the Cleaning chapter).
- ▶ Do not place any hot cookware in the area of the control panel so as not to damage the underlying electronics.
- ▶ When cleaning the device, water must not penetrate the interior of the device. Use only a slightly damp cloth. Never spray the device with water. Water penetration can cause damage!
- ▶ Whenever possible, clean the cooktop after every use.
- ▶ Clean the cooktop only after it has cooled down.
- ▶ When cleaning, only use non-abrasive cleaning agents to prevent scratching and abrasion on the surface.
- ▶ Make sure that the base of the cookware as well as the cooking zone are clean and dry.
- ▶ Always lift (do not drag!) the cookware to prevent scratching and abrasion on the surface.
- ▶ Do not place any hot cookware onto the air inlet nozzle of the cooktop extractor.
- ▶ Make sure that hot cookware does not touch the edge of the air inlet nozzle.

## 2.2 Safety instructions, operation

### Cooktop



#### **DANGER!**

#### **Danger of fire caused by leaving the cooktop unattended!**

Oil or fat in the pot can quickly heat up and ignite.

- ▶ Never leave oil or fat to heat up unattended.
- ▶ Never extinguish oil and fat fires with water.
- ▶ Suffocate the fire, for example by using a lid.



#### **DANGER!**

#### **Danger of explosion caused by flammable liquids!**

Flammable liquids in the vicinity of the cooktop can explode and cause serious injury.

- ▶ Do not place any flammable liquids in the vicinity of the cooktop.



#### **DANGER!**

#### **Danger of electric shock!**

Cracks, fissures or fractures in the glass ceramic panel can damage the underlying electronics. This can cause an electrical shock.

- ▶ If there are any cracks, fissures or fractures in the glass ceramic, switch the device off immediately.
- ▶ Safely disconnect the device from the mains using miniature or automatic circuit breakers, fuses or contactors.



#### **WARNING!**

#### **Risk of burns caused by a hot cooktop!**

The cooktop and its touchable parts become hot during operation. After turning off the cooking zone, allow it to cool down to less than 60°C first. Touching hot surfaces can lead to serious burns.

- ▶ Do not touch the hot cooktop.
- ▶ Keep children away from the hot cooktop unless they are under constant supervision.



**WARNING!**  
**Danger of fire caused by objects on the cooktop!**

The cooktop and its touchable parts become hot when the cooking zone is switched on and while it is cooling down. Objects on the cooktop can heat up and ignite.

- ▶ Do not leave any objects on the cooktop.



**WARNING!**  
**Risk of burns caused by hot objects!**

The cooktop and its touchable parts become hot when the cooking zone is switched on and while it is cooling down. Objects (pot lid, cooktop extractor cover) on the cooktop become hot very quickly and can lead to serious burns.

- ▶ Do not leave any objects on the cooktop.
- ▶ Use suitable aids (pot cloths, thermal glove).



**WARNING!**  
**Risk of burns caused by hot cookware!**

Handles protruding over the worktops can induce children to grab them.

- ▶ Do not turn the handles on the pots or pans to one side over the worktop.
- ▶ Prevent children from pulling down hot pots and pans.
- ▶ A special stove guard for children (available in specialist shops) reduces the danger.



**WARNING!**  
**Risk of burns!**

Liquids between the cooking zone and base of the pot can scald the skin when steaming up.

- ▶ Make sure that the cooking zone and the base of the pot are always dry.

**CAUTION!**  
**Damage caused by hard and pointed objects!**

Hard and pointed objects may cause damage to the glass ceramic plate of the cooktop.

- ▶ Do not use the cooktop surface as a kitchen worktop.
- ▶ Do not use any hard and pointed objects when working on the cooktop.

**CAUTION!**  
**Damage caused by substances containing sugar and salt!**

Substances containing sugar and salt and juices can damage the cooking zone when they are spilled on its hot surface.

- ▶ Make sure that no food or drinks containing sugar or salt and juices are spilled onto the hot cooking zones.
- ▶ Immediately remove food or drinks containing sugar or salt and juices from the hot cooking zone.

**CAUTION!**  
**Escaping hot liquids!**

Unattended pans can boil over allowing hot liquids to escape.

- ▶ Always keep an eye on pans while cooking.
- ▶ Short cooking sessions must be constantly monitored.

## Cooktop extractor



**DANGER!**  
**Danger to life caused by smoke poisoning!**

Combustion gases arise when running a fireplace that depends on the air in the room.

If you operate the cooktop extractor with a fireplace that depends on the air in the room at the same time, poisonous combustion gases (carbon monoxide) may be drawn from the chimney or extraction duct into the living room.

- ▶ Make sure that there is always enough air supply.



**DANGER!****Risk of fire through flambéing!**

While in operation, the cooktop extractor draws off cooking fat. When flambéing food, the cooking fat can catch fire.

- ▶ Clean the cooktop extractor at regular intervals.
- ▶ Do not carry out any work involving an open flame when the cooktop extractor is switched on.

**DANGER!****Danger of fire due to grease deposits!**

By failing to clean the stainless steel grease filter at regular intervals, increased amounts of grease may accumulate in it. This increases the risk of fire.

- ▶ Clean or replace the filters at regular intervals.

**CAUTION!****Touchable parts may become hot!**

The cooktop extractor and its touchable parts are hot when the cooking zone is switched on and during the cooling phase.

- ▶ Do not place any items on the cooktop.
- ▶ Please use suitable tools (pot holders, oven gloves).

**WARNING!****Danger of injury when opening the bottom housing cover!**

There is a risk of injury while the fan is turning.

- ▶ Switch off the cooktop extractor and the cooktop.
- ▶ Turn off the fuse.

**CAUTION!****Damage caused by objects or paper being sucked in!**

Small and light objects such as cleaning wipes made of fabrics or paper can be sucked into the cooktop extractor. As a result, the fan can be damaged or the fan output can be impaired.

- ▶ Do not store any objects or paper on the cooktop extractor.

**CAUTION!****Damage caused by fat or dirt deposits!**

Fat or dirt deposits can impair the functioning of the cooktop extractor.

- ▶ Never use the cooktop extractor without a stainless steel grease filter.

## 2.3 Safety instructions, assembly

Installation and assembly of the device may only be carried out by trained personnel who are familiar with and comply with common national regulations and supplementary regulations of the local utility companies.

Work on electrical parts must only be carried out by trained electrical personnel.

The electrical safety of the device is only guaranteed if it is connected to a properly installed protective conductor system. Make sure that these basic safety precautions have been taken.

## Cooktop



### **DANGER!**

#### **Danger of electric shock!**

Connecting the device incorrectly to the mains poses a risk of electric shock.

- ▶ Make sure that the device has a fixed connection to the mains voltage.
- ▶ Make sure that the device is connected to a properly installed protective conductor system.
- ▶ Make sure that technical equipment is provided to allow for all of the device's poles to be disconnected from the mains with a contact opening width of at least 3 mm (miniature and automatic circuit breakers, fuses, contactors).



### **DANGER!**

#### **Danger of electric shock!**

The connection cable can be damaged if it comes into contact with hot cooking zones. A damaged connection cable can cause a (fatal) electrical shock.

- ▶ Make sure that the connection cable does not come into contact with hot cooking surfaces.
- ▶ Make sure that the connection cable is not caught or damaged.



### **CAUTION!**

#### **Back injury caused by heavy loads!**

When removing and inserting the device, incorrect handling may cause injuries to the limbs and the trunk.

- ▶ Always lift the device out of the packaging with two persons.
- ▶ Always place the device onto the worktop cut-out with two persons.
- ▶ Use suitable aids to prevent damage to the limbs and the trunk.

## Cooktop extractor



### **DANGER!**

#### **Risk of poisoning caused by combustion gases!**

When the cooktop extractor is used for exhaust operation, it draws in air from the room it is installed in and from neighbouring rooms. Without sufficient air, negative pressure will occur. Toxic gases could be drawn out of the chimney or extraction ducting on a fireplace that depends on the room air and back into the room.

- ▶ Make sure there is always enough air supply.
- ▶ Use technical safety measures (e.g. window contact switch, low pressure warning device) and have them approved by a qualified expert (certified chimney-sweep).



### **DANGER!**

#### **Risk of electric shock!**

Incorrect stripping of the connection cable to external switching devices results in a risk of electric shock. Ensure that the stated stripping lengths are adhered to.

- ▶ Check the device for visible damages before installing it.
- ▶ Do not install a damaged device.
- A damaged device may put your safety at risk!

Repair and maintenance work may only be carried out by specialists authorised by the manufacturer.

## 2.4 Safety instructions, disassembly and disposal

Disassembly of the device may only be carried out by trained personnel who are familiar with and comply with common national regulations and supplementary regulations of the local utility companies.

Work on electrical parts may only be carried out by trained electrical personnel.

**DANGER!****Danger of electric shock!**

Disconnecting the device incorrectly from the mains poses a risk of electric shock.

- ▶ Safely disconnect the device from the mains using miniature or automatic circuit breakers, fuses or contactors.
- ▶ Use a suitable measuring device to ensure that the device is de-energised.

**DANGER!****Risk of suffocation!**

Parts of the packaging (e.g. films, polystyrene) can be fatal to children.

- ▶ Store packaging materials away from the reach of children.
- ▶ Dispose of packaging correctly and promptly.

Not using the device as described in this operating and assembly manual is considered not using the device as intended, as is using it beyond the purpose described here.

BORA shall not assume any liability for damages caused by improper use or incorrect operation.

**All misuse is prohibited!****INFO**

BORA Holding GmbH,  
BORA Vertriebs GmbH & Co KG,  
BORA APAC Pty Ltd and  
BORA Lüftungstechnik GmbH shall not assume any liability for damage arising from non-adherence to the safety and warning instructions.

## 2.5 Safety instructions, spare parts

**WARNING!****Risk of injury and damage to property!**

Incorrect parts can lead to injury to persons or damage to device! Modifications, attachment parts or conversions to device can impair safety.

- ▶ Only use original spare parts when carrying out repairs.

## 2.6 Use as intended

The device is solely intended for preparing food in private households.

This device is not designed for:

- use outdoors
- installation in vehicles
- heating the room
- use in non-fixed installation sites (e.g. on ships)
- use with an external timer or separate remote control system.

### 3 Technical data

Parameter	Value
Supply voltage	380-415 V
Frequency	50/60 Hz
Power consumption	7.6 kW
Fuse protection, minimum	1 x 32 A / 2 x 16 A
Total power	7.6 kW
Line-to-line voltage	AC 220-240 V / 50 Hz
Main dimensions	830 x 515 x 198 mm
Weight (incl. accessories/packaging)	Approx. 25 kg
<b>Cooktop</b>	
Front cooking zones	205 x 230 mm 2100 W
power setting	3700 W
Rear cooking zones	205 x 230 mm 2100 W
power setting	3700 W
Power levels	1-9, power setting
<b>Cooktop energy consumption</b>	
Cooking zone 1	176.5 (Wh/kg)
Cooking zone 2	172.2 (Wh/kg)
Cooking zone 3	177.2 (Wh/kg)
Cooking zone 4	175.9 (Wh/kg)
Total (average)	175.5 (Wh/kg)
<b>Extraction system (BFIA)</b>	
Maximum flow volume	697.3 m <sup>3</sup> /h
Maximum static pressure	372 Pa
Power control	1-9, power setting
Exhaust air connection (BFIA)	222 x 40 x 89 mm
<b>Recirculation system (BFIU)</b>	
Maximum flow volume	658.8 m <sup>3</sup> /h
Maximum static pressure	375 Pa
Power control	1-9, power setting
Recirculation connection (BFIU)	650 x 90 mm
<b>Recirculation filter</b>	
Filter area	2 x 0,4 m <sup>2</sup>
Filter capacity	150 operating hours
Service life	1 year

Tab. 3.1 Technical data

## 4 Energy label

Product description			
Glass ceramic cooktop with 4 cooking zones and an integrated cooktop extractor	BFIA	BFIU	
Operating mode	Exhaust air	Recirculation	
Energy consumption	Value	Value	EN standard
Annual energy consumption ( $AEC_{hood}$ )	54,8 kW/a	51,9 kW/a	61591
Energy efficiency class	B	*	61591
Flow volume			
Fluid dynamic efficiency ( $FDE_{hood}$ )	23.1	21.0	61591
Fluid dynamic efficiency class	B	*	61591
Lighting			
Lighting efficiency ( $LE_{hood}$ )	* lx/Watt	* lx/Watt	*
Lighting efficiency class	*	*	*
Grease filtering			
Level 9 maximum ( $GFE_{hood}$ )	91 %	91 %	61591
Class level 9 normal	B	*	61591
Grease filtering (additional details)			
Level P maximum ( $GFE_{hood}$ )	93 %	93 %	61591
Class level P maximum	B	*	61591
Flow volume			
Air flow level 1 minimum	194.8 m <sup>3</sup> /h	* m <sup>3</sup> /h	61591
Air flow level 9 normal	607.3 m <sup>3</sup> /h	* m <sup>3</sup> /h	61591
Air flow level P maximum ( $Q_{max}$ )	697.3 m <sup>3</sup> /h	658.8 m <sup>3</sup> /h	61591
Sound power level			
Level 1 minimum	40 dB(A)	39 dB(A)	60704-2-13
Level 9 normal	66 dB(A)	67 dB(A)	60704-2-13
Level P maximum	70 dB(A)	70 dB(A)	60704-2-13
Sound pressure level (additional details)			
Level 1 minimum	27 dB(A)	26 dB(A)	**
Level 9 normal	54 dB(A)	54 dB(A)	**
Level P maximum	57 dB(A)	57 dB(A)	**
Details according to 66/2014			
Power consumption in off mode ( $P_o$ )	< 0.5 W	< 0.5 W	61591
Time increase factor	1.2	1.2	61591
Energy efficiency index ( $EEl_{hood}$ )	65.2	64.5	61591
Air flow rate at the best efficiency point ( $Q_{BEP}$ )	382 m <sup>3</sup> /h	311.4 m <sup>3</sup> /h	61591
Pressure at the best efficiency point ( $P_{BEP}$ )	272 Pa	288 Pa	61591
Electric power input at the best efficiency point ( $W_{BEP}$ )	125 W	118.5 W	61591

Tab. 4.1 Energy label information

(The recirculation information is optional and not subject to mandatory inclusion on the label)

\* This specification is not applicable for this product.

\*\* The sound pressure level has been determined from a distance of 1 m (distance-dependent level recording) on the basis of the sound power level established in EN 60704-2-13.

## 5 Device description

Observe all safety and warning information during operation (see the Safety chapter).

The cooktop with cooktop extractor has the following features:

### Cooktop:

- Automatic heat up function
- Safety shut-down
- Bridging function
- Electronic power control (9 power levels)
- Childproofing feature
- Pause function
- power setting
- Residual heat display
- Timer functions
- Pan size recognition
- Heat retention levels

### Cooktop extractor:

- Freely adjustable power control
- Automatic cooktop extractor function
- Automatic after-run
- Safety shut-down
- Filter service display
- Interface communication

Depending on what you opted for when purchasing, the cooktop extractor can be operated as an exhaust air or an recirculating air version.



### Exhaust mode

The air extracted from the cooktop is cleaned by the stainless steel grease filter and released outside through a duct system.

The exhaust air must not be expelled into:

- a smoke or exhaust gas flue that is in operation;
- a shaft used for the aeration of rooms where fireplaces are installed.

If the exhaust air is to be directed into a smoke or exhaust gas flue that is not in use, the installation must be checked and approved by the responsible heating engineer.



### Recirculation mode

The air suctioned away by the cooktop is purified by the stainless steel grease filter and an activated charcoal filter and fed back into the room in which the appliance is installed. To prevent odours in the recirculated air, an activated charcoal filter must be used. For hygiene and health

reasons, the activated charcoal filter must be replaced at the recommended intervals (see the Cleaning and maintenance section).

**INFO** In recirculation mode, ensure sufficient ventilation and aeration to expel humidity.

The activated charcoal filter is equipped with an integrated fine filter. The filter in the activated charcoal filter is made from special activated charcoal, which is ideal for trapping cooking odours.

### 5.1 Structure



Abb. 5.1 Cooktop

- [1] Air inlet nozzle
- [2] Stainless steel grease filter
- [3] Cooktop
- [4] Suction opening
- [5] Operating panel

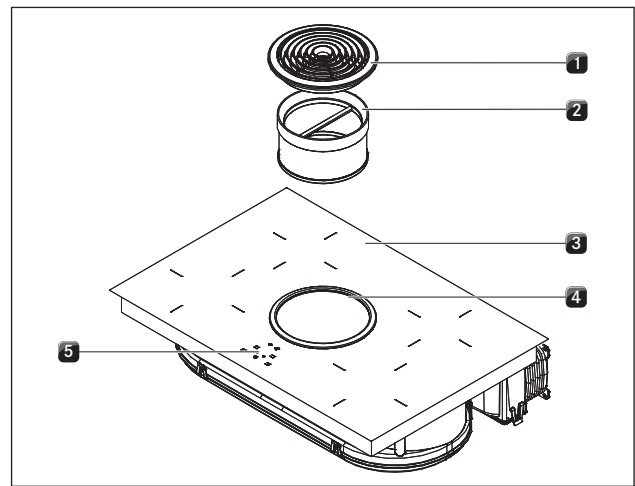

Abb. 5.2 Cooktop extractor – recirculation (BFIU)

- [1] Flexible duct
- [2] Activated charcoal filter housing
- [3] Activated charcoal filter housing cover
- [4] Activated charcoal filter
- [5] Air guiding housing with housing base

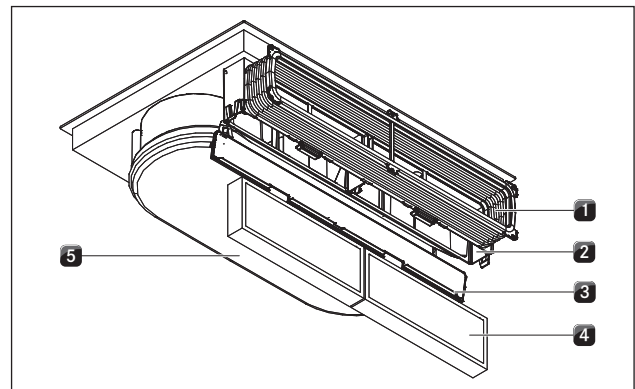

Abb. 5.3 Cooktop extractor – exhaust air (BFIA)

- [1] Exhaust air arc with duct connection
- [2] Horizontal exhaust air extension
- [3] Air guiding housing with housing base

## 5.2 Operating panel and operating principle

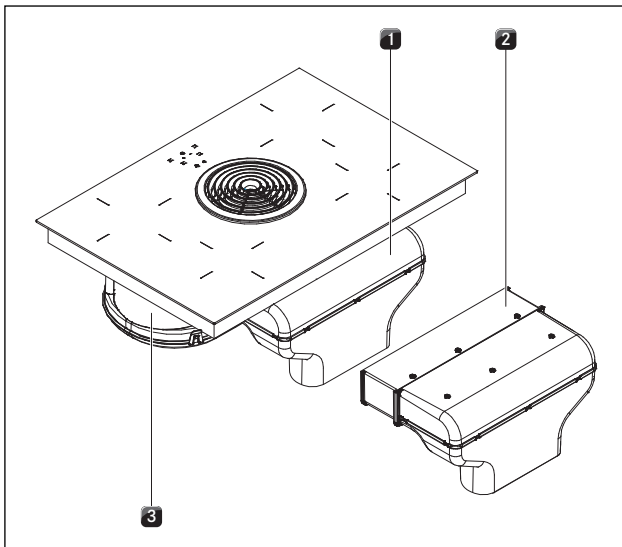

Abb. 5.4 Operating panel

### Sensor buttons:

- [1] Switching the cooktop/cooktop extractor on/off
- [3] Multi-function button
- [5] Activating the timer
- [5] Setting the timer value (+10 min)

### Setting ring:

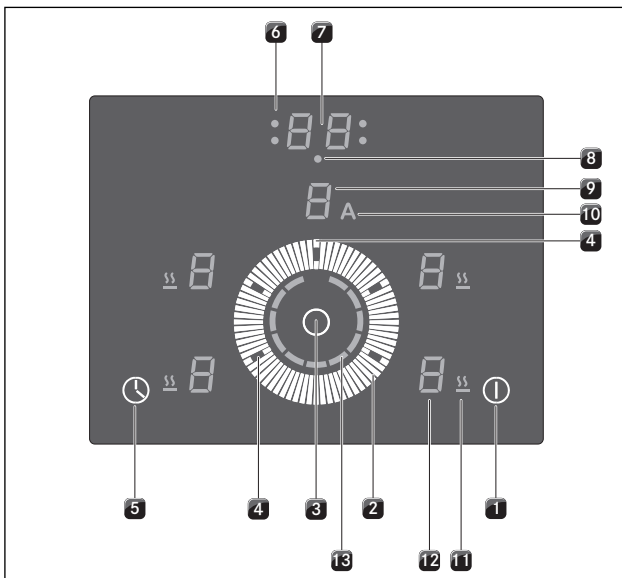
- [2] Adjusting the power level
- [2] Setting the timer value (minutes)
- [2] Locking/unlocking the childproofing feature
- [2] Locking/unlocking the pause function

- [4] Selecting the cooking zone
- [4] Selecting the cooktop extractor

### Display fields:

- [6] Automatic cut-off timer control light
- [7] Timer display
- [8] Short-time timer control light
- [9] Fan display/filter service display
- [10] Automatic cooktop extractor display
- [11] Heat retention level display
- [12] Cooking zone indicator
- [13] Power display

Display field	Display	Meaning
Fan display	0	Fan off
	1 - 9	Power level
	P	Power setting
	n	Automatic after-run
	F	Filter service display
Automatic cooktop extractor function	A	Active
Cooking zone indicator	1 - 9	Power level
	P	Power setting
	A	Automatic heat up function
	L	Childproofing feature
	n	Bridging function
		Break
	-	Heat retention level 42°C
	=	Heat retention level 74°C
	≡	Heat retention level 94°C
	u	No cookware or cookware is too small.
	H	Residual heat display: Cooking zone is switched off but still hot (temperature > 60°C)
Heat retention level display	On	Active
Timer control light	On	Active
	Flashes	Timer on (00); no time set
	Off	Timer off
Timer display	01 - 99	Set minutes for short time (egg timer) or automatic cut-off
	00	Timer on; no time set

Tab. 5.1 Meaning of displays

### Touch control

The operating panel is fitted with electronic sensor buttons, a setting field and display panels. The sensor buttons respond to finger contact.

You operate the device by touching the corresponding sensor button with your finger. Keep the finger pressed on the sensor button until you either hear an acoustic signal or the display changes accordingly.

## 5.3 Functional principle of the cooking zone

An induction coil is located underneath an induction cooking zone. If the cooking zone is switched on, this coil creates a magnetic field that acts directly on the base of the pot thus heating it up. The cooking zone is only indirectly heated up by the heat emitted by the pot. Cooking zones with induction only work if the cookware has a magnetisable base.

The induction automatically takes into account the size of the cookware used so that only the area in the cooking zone covered by the base of the pot is heated up.

► Observe the minimum pot base diameter.

The cooking zone does not work

- if it is switched on without cookware or with unsuitable cookware;
- if the base diameter of the cookware is too small;
- if the cookware is removed from a switched on cooking zone.

A  $\sqcup$  will appear in the cooking zone indicator if cookware that is unsuitable or too small is used.

### 5.3.1 Power levels

The high power output of induction cooktops results in the very quick heating up of cookware. A slight adjustment is needed in comparison to conventional cooking systems when selecting the power level in order to avoid burning food.

Activity	Power level
Melting of butter and chocolate, breaking up gelatine	1
Keeping sauces and soups warm, soaking rice	1-3
Cooking potatoes, pasta, soups, ragouts, steaming fruit, vegetables and fish, defrosting food	2-6
Frying in coated pans, moderate frying (without overheating the fat) of pork cutlets, fish	6-7
Heating up fat, browning fish, cooking thickened sources and soups, making omelettes	7-8
Cooking large quantities of liquid, browning steaks	9
Heating up water	P

Tab. 5.2 Recommendations for power levels

The specifications provided in the table are standard values.

Depending on the cookware and filling quantity, it is recommended to either decrease or increase the power level.

### 5.3.2 Automatic heat up function

The cooking zones are equipped with an automatic heat up function that can be switched on and off.

■ The display shows  $\text{H}$ .

This function enables the cooking zone to work at full power for a certain duration after switching on. After this time, the power level is automatically switched back to the power level set.

#### Automatic heat up function

Power level	1	2	3	4	5	6	7	8
Cooking duration in min./sec	0:48	2:24	3:50	5:12	6:48	2:00	2:48	3:36

Tab. 5.3 Overview of the automatic heat up function

### 5.3.3 power setting

All cooking zones are equipped with a power-enhancing power setting.

The power setting can be used in order to quickly heat up large quantities of water. If the power setting is activated, the cooking zones will run at extra high power. After 10 minutes, the cooking zone is automatically switched to power level  $\text{9}$ .

If the bridging function is activated, the power setting cannot be used.

If cooking zone overheating protection is activated, the power setting cannot be activated. The display flashes for 3 seconds and then switches back.

#### INFO

Never heat up oil, fat and the like at this power setting. The bottom of the pan can overheat due to the high power output.

### 5.3.4 Heat retention levels

The heat retention level keeps cooked foods warm at different temperatures.

- The heat retention level display is active and lit.
- The heat retention level is shown in the cooking zone indicator e.g. for level 2  $\text{=}$ .
- The maximum duration for the warming function is limited to 8 hours.

Heat retention level	Temperature in °C
Level 1	42 °C
Level 2	74 °C
Level 3	94 °C

Tab. 5.4 Heat retention levels

### 5.3.5 Bridging function

The two side cooking zones can be operated as a connected cooking zone at the same power level.

■ The display shows  $\text{H}$ .

The bridging function is suitable for heating food in a roaster.



### 5.3.6 Pause function

The cooking session can be temporarily interrupted.

- **|||** appears in the display.
- The cooking session and set timer are interrupted while the pause function is active.
- The pause function is limited to a maximum duration of 10 minutes.

### 5.3.7 Timer functions

You can use 2 timer functions:

- Short-time timer (egg timer), no automatic switching off of a cooking zone.
- Automatic cut-off for automatically switching off a cooking zone.

### 5.3.8 Pan size recognition

The cooking zone does not work

- if **⏏** is shown in the display;
- if it is switched on without cookware or with unsuitable cookware;
- if the base diameter of the cookware is too small;
- if the cookware is removed from a switched on cooking zone.
- After 10 minutes have passed without a pan being detected, the cooking zone will switch off automatically.

### 5.3.9 Suitable cookware

**INFO** The heating and heat through time for the base of the cookware as well as the cooking results are significantly influenced by the structure and material of the cookware.



Cookware with this symbol is suitable for induction cooktops.

The cookware used for the induction cooktop must be made of metal, feature magnetic properties and possess a sufficient bottom surface.

Suitable cookware is made of:

- stainless steel with a magnetisable base
- enamelled steel
- cast iron

Cooking zone	Minimum diameter
Front	120 mm
Back	120 mm

Tab. 5.5 Minimum cookware diameter

- ▶ Perform a magnet test, if necessary. If a magnet sticks to the base of the utensils, they are normally induction compatible.

- ▶ Pay attention to the cookware bottom. The base of the cookware should not show any sign of curvature. Due to incorrect temperature monitoring of the hob caused by the air gap between the cookware and the temperature sensor underneath the hob, overheating may occur. The bottom of the cookware must not have any sharp grooves or sharp edges to avoid scratching the cooktop.
- ▶ Place the cookware (without a mat or similar) directly onto the glass ceramic.

### Noises

The following noises may occur in the cookware when using induction cooking zones, depending on the material and the finish of the base:

- **Humming** may occur when using a high power level. It decreases or disappears if the power level is decreased.
- **Crackling or whistling** may occur due to the bases of cookware made of different materials (e.g. sandwich base).
- **Clicking sounds** may occur during electronic switching procedures especially at low power levels.
- **Whirring** may occur when the cooling fan is switched on. In order to increase the service life of the electronic system, the cooktop is equipped with a cooling fan. The cooling fan switches on automatically if the cooktop is used intensively. You will hear a whirring sound. The cooling fan may continue running after the device has been switched off.

## 5.4 Functional principle of the cooktop extractor

### 5.4.1 Freely adjustable power control

The power levels are controlled using the central setting field on the operating panel.

### 5.4.2 Automatic cooktop extractor function

The automatic cooktop extractor function adjusts the extraction performance (power level) to the highest cooking zone cooking level used.

Function	Power levels									
Extractor level	4	4	4	4	5	6	7	8	9	P
Cooking level	1	2	3	4	5	6	7	8	9	P

Tab. 5.6 Extraction performance and cooking level

- If the power level of the cooking zones is changed, the automatic cooktop extractor function adjusts the cooktop extractor performance after a 30 second delay.
- Once the cooking session is complete, the automatic after-run is activated.

### 5.4.3 Power setting

The cooktop extractor has a power-enhancing power setting.

This power setting makes it possible to suction away high levels of cooking vapours more quickly. After 10 minutes, the power setting is automatically switched to power level 9.

### 5.4.4 Automatic after-run

The cooktop extractor continues to run at a lower level  $\eta$  and switches off automatically after 20 minutes.

### 5.4.5 Filter service display

The filter service display becomes active after the cooktop extractor has operated for 150 hours. The activated charcoal filters have reached the end of their service life (with recirculation only) and the stainless steel grease filter needs to be thoroughly cleaned.

■ A flashing  $F$  is displayed in the filter service display.

### 5.4.6 Interface communication

The internal interface can be used for extended control options. This has a Home-In and a Home-Out contact (see Installation chapter).

■ The Home-In contact can be used for the incoming signal from external switch devices (e.g. window contact switch).

■ The Home-Out contact can be used to control external installations.

## 5.5 Safety devices

### 5.5.1 Residual heat display

**INFO** While  $H$  is displayed in the cooking zone indicator (residual heat display), do not touch the cooking zone or place any heat-sensitive objects on top of it. Risk of burns and fire!

After switching it off, the cooking zone remains hot.  $H$  is displayed in the cooking zone indicator (residual heat display). The cooking zone indicator will go out after sufficient cooling time (temperature < 60°C).

### 5.5.2 Safety shut-down

#### Cooking zone

Each cooking zone is switched off automatically when the cooking zone exceeds the maximum operating duration at a power level.  $H$  (residual heat display) is then displayed in the cooking zone indicator.

Heat retention level	Power level	Switch off after hours
1		8.0
2		8.0
3		8.0
	1	8.4
	2	6.4
	3	5.2
	4	4.2
	5	3.3
	6	2.2
	7	2.2
	8	1.5
	9	1.3
	P	0.2

Tab. 5.7 Overview of the safety shut-down

► Switch the cooking zone back on (see Operating control) if you want to put the cooking zone back into operation.

### Cooktop extractor

The cooktop extractor switches off automatically if no buttons are pressed for 120 minutes.

### 5.5.3 Cooking zone overheating protection

All induction coils plus the cooling elements of the electronics are equipped with overheating protection. Before the induction coils and/or cooling elements overheat, the overheating protection will initiate one of the following measures:

■ The power setting  $P$  is automatically switched to power level 9 after 10 minutes. The cooking zone indicator  $P$  switches to 9.

■ The set power level is reduced.

■ The cooking zones switch off automatically.

$H$  (residual heat display) is displayed in the cooking zone indicator if the cooking zone is still hot.

### 5.5.4 Automatic switch-off if the button is pressed and held

The cooktop will be switched off automatically when one or more sensor buttons are touched for longer than 10 seconds (finger contact, objects, soiling).

■ After a few seconds, the cooktop will switch off.

► Remove the finger or object from the cooktop.

► Clean the cooktop as required.

► Where necessary, switch the cooktop back on.

### 5.5.5 Childproofing feature

The childproofing feature prevents the cooktop from being switched on accidentally. The childproofing feature can only be activated when the cooktop is switched on and all cooking zones are switched off (see the Operation chapter).

## 6 Installation

- ▶ Observe all safety and warning information (see the Safety chapter).
- ▶ Follow the enclosed manufacturer's information.

**INFO** The power supply cable must be provided by the customer.

**INFO** The device must not be installed above cooling devices, dishwashers, stoves, ovens, washing machines or dryers.

**INFO** The contact surfaces of the worktops and wall sealing strips must be made of a heat-resistant material (up to approx. 100°C).

**INFO** Worktop cut-outs must be moisture-sealed using suitable means and, where necessary, fitted with a thermal insulator.

### 6.1 Checking the scope of delivery

Name	Quantity
Surface induction glass ceramic cooktop with cooktop extractor	1
Stainless steel grease filter	1
BAKF activated charcoal filter	2
Flexible duct (BFIU only)	1
EURO screws (BFIU only)	6
BLAVH horizontal exhaust air extension (BFIA only)	1
Mounting straps	5
Sealing tape	1
Glass ceramic scraper	1
Cable routing clips	3
Protective hose	2
Cable tie	2
Operating and installation instructions	1
Lenshead screw	5
Drilling template (BFIU only)	1
Height adjustment plate set	2

Tab. 6.1 Scope of delivery

- ▶ Check the scope of delivery for damage and make sure it is complete.
- ▶ If there are any missing or damaged parts, please notify BORA After Sales Service immediately.
- ▶ Do not under any circumstances install parts which are damaged.
- ▶ Dispose of transport packaging in the proper manner (see the Decommissioning, Disassembly and Disposal chapter).

### 6.2 Tool and aids

The following tools are required for the correct installation of the cooktop:

- Pencil
- Standard or cordless drill with a 5 mm wood drill (for the rear wall)
- Compass saw or hand saw
- Drilling template for cut-out on rear wall (included in scope of delivery)
- Phillips screwdriver Z2
- Silicone sealant for sealing cutting surfaces

### 6.3 Assembly instructions

#### 6.3.1 Safety distances

- ▶ Maintain the following safety distances:



Abb. 6.1 Recommended minimum clearances

- [1] Rear minimum clearance of 50 mm between the worktop cut-out and the rear corner of the worktop.
- [2] Minimum clearance of 300 mm from the left and right of the worktop cut-out to the adjacent cabinet or wall.
- [3] Minimum clearance of 600 mm between the worktop and the wall unit. A minimum clearance of 1000 mm is recommended for ergonomic reasons.

### 6.4 Cut-out dimensions for the cooktop

#### Preparing the worktop

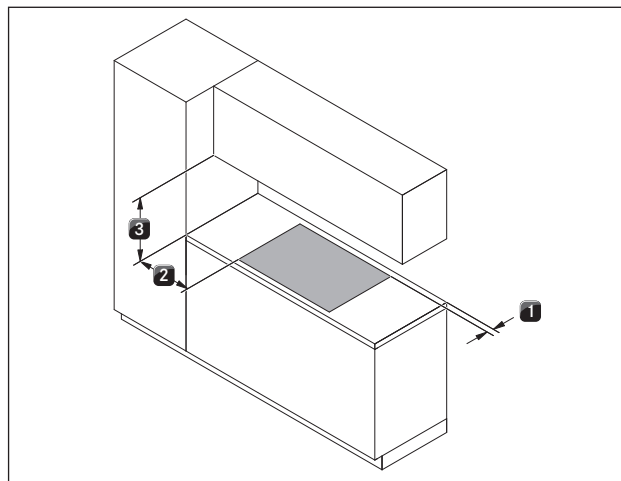
- ▶ Create the worktop cut-out taking into account the specified cut-out dimensions.
- ▶ Make sure that the cutting surfaces of the worktops are properly sealed.
- ▶ Comply with the instructions of the worktop manufacturer.

- Cross bars on the kitchen unit in the area of the worktop cut-out may need to be removed.
- No false floor is necessary below the cooktop with cooktop extractor.
- Make sure that the area below the device is sufficiently ventilated.
- An opening cross-section of  $> 50 \text{ cm}^2$  must be available at the front and in the false floor for the ventilation of the cooktop's induction equipment.
- The drawers and/or shelves in the floor unit must be removable.
- A return flow aperture  $> 500 \text{ cm}^2$  is required in the kitchen units for recirculation appliances (e.g. by shortening the plinth boards or using suitable slatted plinths).
- The power socket is located at the bottom of the front of the device.

### Flush installation



Abb. 6.2 Cut-out dimensions for flush installation



Abb. 6.3 Dimension of groove for flush installation

### Surface mounting

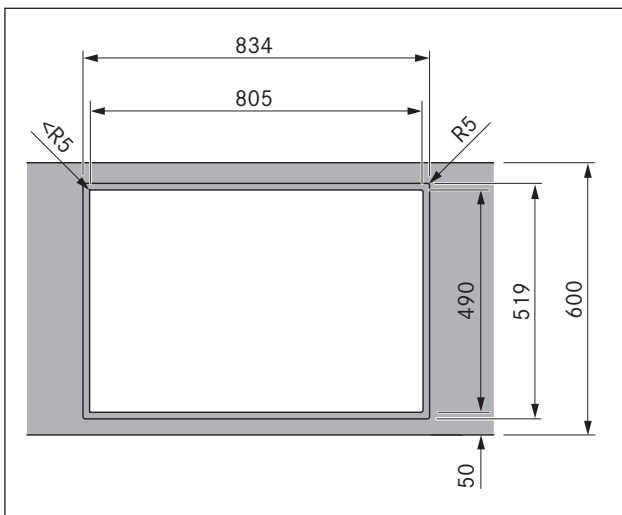

Abb. 6.4 Cut-out dimensions for surface mounting

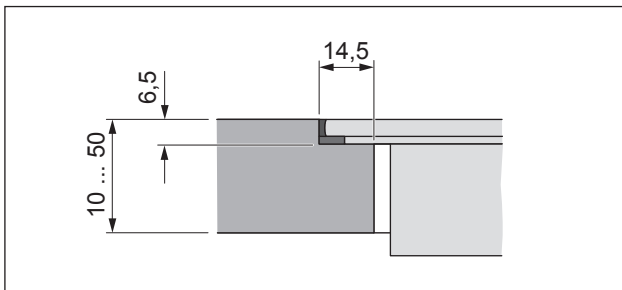

Abb. 6.5 Dimension of support for surface mounting

### Attaching the sealing tape

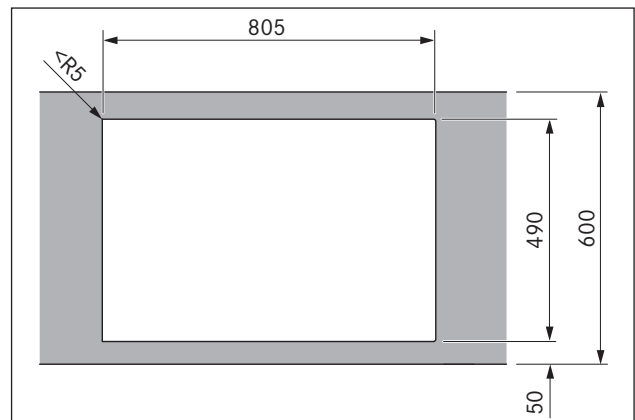

Abb. 6.6 Sealing tape with surface mounting

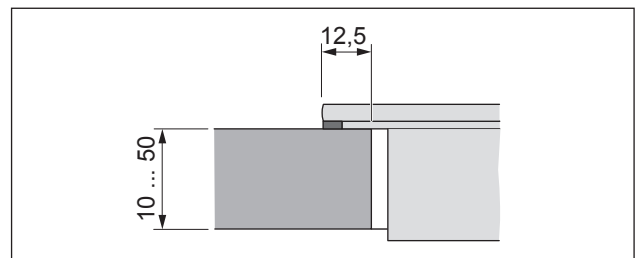

Abb. 6.7 Sealing tape, flush installation

- [1] Black heat-resistant silicone sealing compound
- [2] Sealing tape

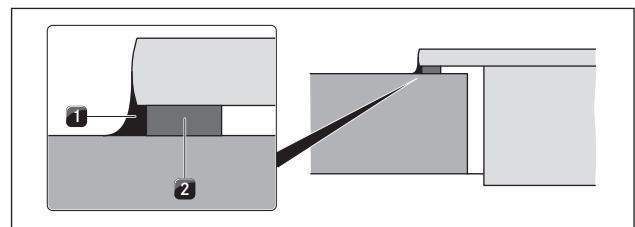
- ▶ With surface mounting, attach the enclosed sealing tape [2] to the underside of the cooktop before installing it. Do not leave any gaps.
- ▶ With flush installation, attach the enclosed sealing tape [2] to the horizontal cutting edge in the worktop cut-out, even if you are sealing the cooktop with a silicone sealing compound [1] or similar.
- ▶ Precisely align the cooktop.

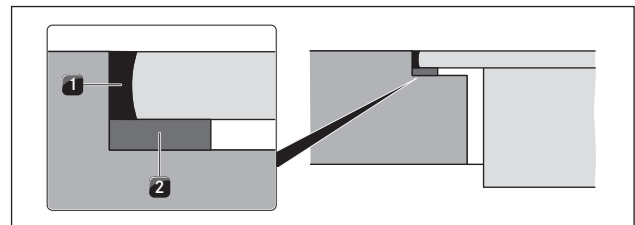

Abb. 6.8 Height adjustment plates

- [1] Cooktop  
[2] Height adjustment plate

- ▶ If applicable, insert the height adjustment plate [2].
- ▶ Note down the type designation and build number of the cooktop (FD number) on the back of this manual. Both details can be found on the nameplate on the underside of the cooktop.

## 6.5 Installing the recirculation version (BFIU)

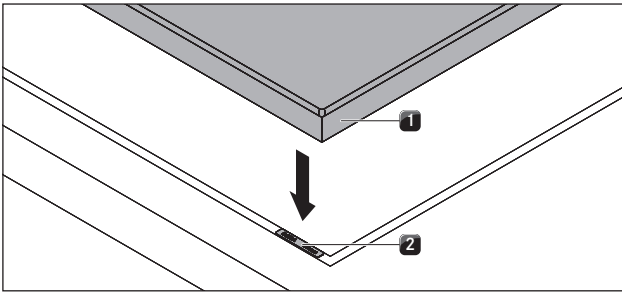
**INFO** A minimum clearance of 25 mm must be provided for the vertical return flow aperture.

**INFO** A return flow aperture of at least 500 cm<sup>2</sup> must be provided.

If the cooktop extractor is used exclusively in recirculation mode, operation with an open fireplace is possible without any additional safety measures.

### Installation dimensions



Abb. 6.9 Device dimensions for recirculation



Abb. 6.10 Furniture dimensions for recirculation

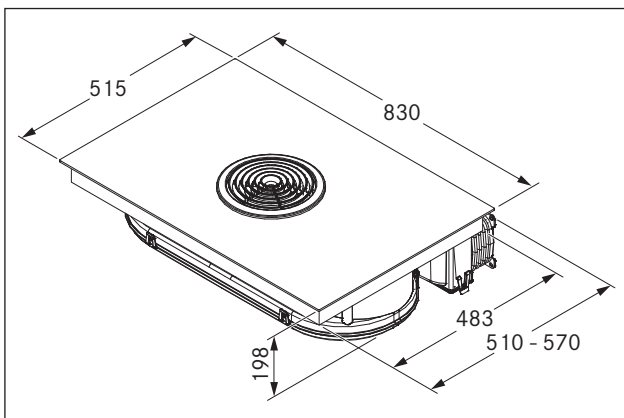

Abb. 6.11 Installation dimensions for recirculation, depth of worktop 600 mm

- The floor unit must have a continuous back wall so that the recirculation air is not directed into the front furniture body compartment.
- There must be a cut-out in the back wall.

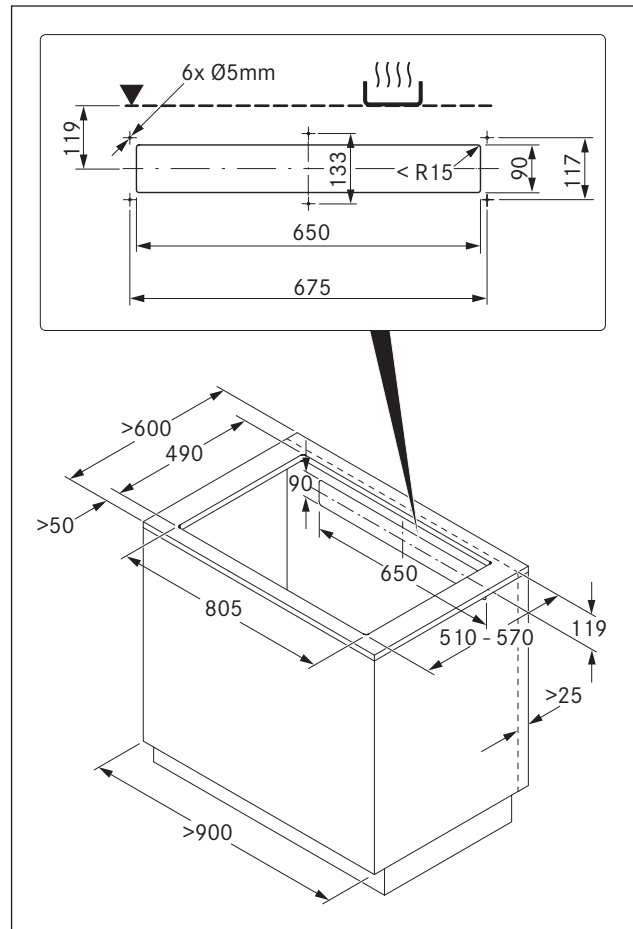
- A minimum clearance of 25 mm between the back furniture body wall and an adjacent kitchen unit or room wall must be observed for the return flow aperture.

#### Preparing the back wall of the kitchen unit

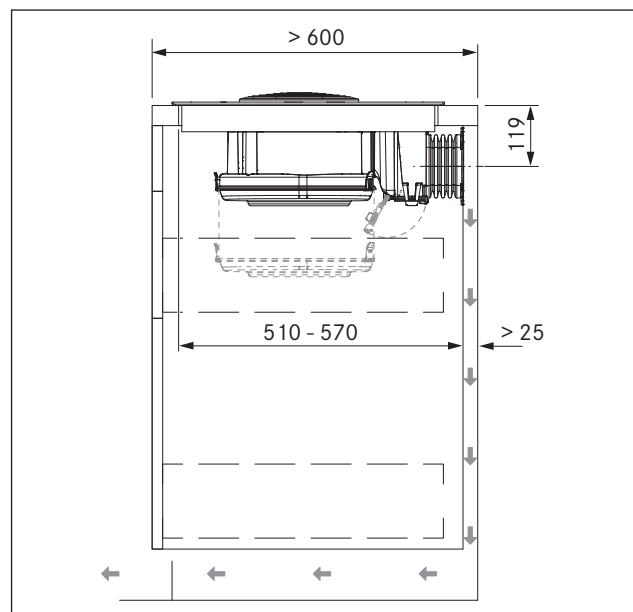
- ▶ Adjust the back wall according to the required installation dimensions.
- ▶ If applicable, move the back wall.
- ▶ If necessary, extend the height of the back wall so that the unit is closed to the front.



Abb. 6.12 Cut-out and connection requirements

- ▶ In the middle of the cooktop, use the drilling template provided to mark the return flow aperture and the connection drill holes in accordance with the installation dimensions.
- ▶ Saw out the return flow aperture.
- ▶ Drill the connection drill holes.
- ▶ Decrease the height of the skirting boards or create corresponding openings in the plinth.

#### Screwing on the flexible duct

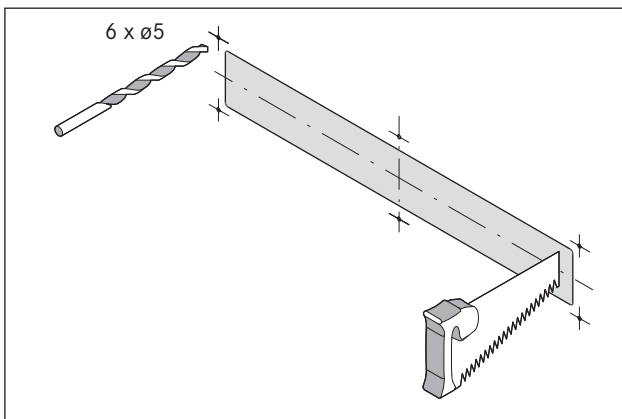

Abb. 6.13 Flexible duct with 6 EURO screws 6.3 x 10 mm

- ▶ Use a screwdriver (not an electric screwdriver) to screw the flexible duct to the back wall of the kitchen unit until it is hand-tight.

#### Inserting the cooktop

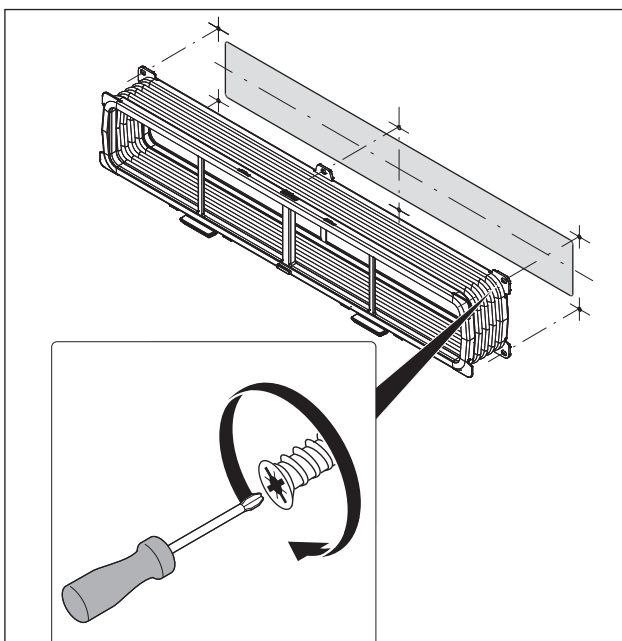

Abb. 6.14 Insert the cooktop obliquely

- [1] Cooktop
- [2] Suction opening
- [3] Air inlet nozzle
- [4] Stainless steel grease filter
- [5] Worktop cut-out

- ▶ Before inserting the cooktop, remove the air inlet nozzle [3] and the stainless steel grease filter [4].
- ▶ Use the suction opening as a handle during insertion.
- ▶ Insert the cooktop obliquely into the worktop cut-out [5].

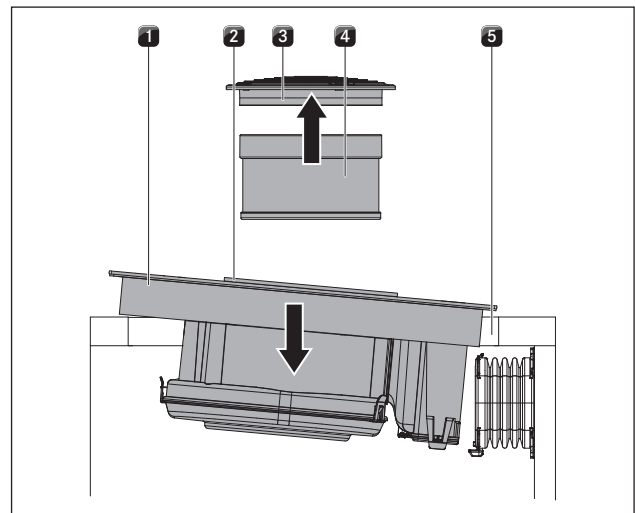

Abb. 6.15 Opening the housing cover

- [1] Housing cover of the activated charcoal filter

- ▶ Open the housing cover of the activated charcoal filter [1] from below.

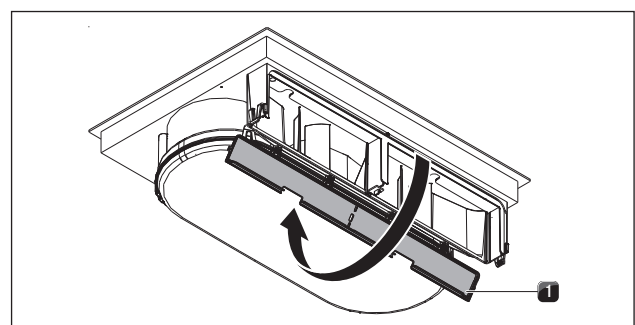

Abb. 6.16 Mounting the frame of the flexible duct

- [1] Retaining groove of the housing of the activated charcoal filter
- [2] Position shackles
- [3] Flexible duct frame
- [4] Lower lock

- ▶ Insert the frame of the flexible duct into the retaining groove on the housing of the activated charcoal filter [1].
- ▶ Ensure that both lateral position shackles [2] are in the guide.
- ▶ Slide the frame upward [3] until the lower [4] and upper lock engage in the middle.
- ▶ Ensure that the frame is inserted into the housing groove [1] all round.

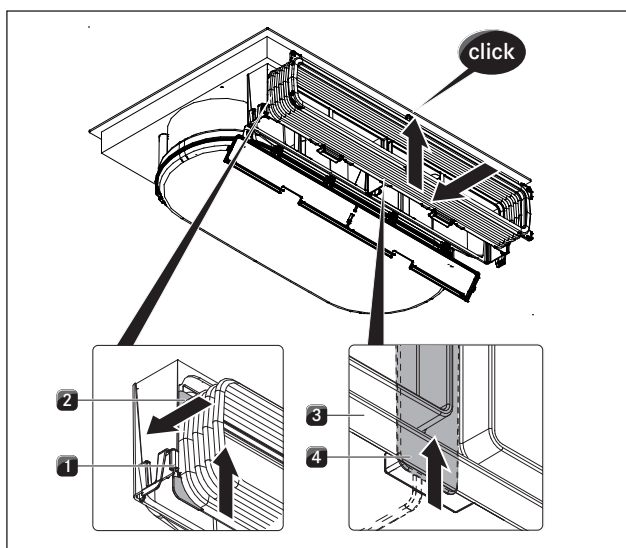

Abb. 6.17 Inserting the activated charcoal filter

- [1] Housing cover of the activated charcoal filter
- [2] Activated charcoal filter

- ▶ Remove the packaging from the activated charcoal filters.
- ▶ Insert the two activated charcoal filters [2] from below.
- ▶ Check the direction of flow of the filters. This is identified by an arrow.
- ▶ Close the housing cover [1].

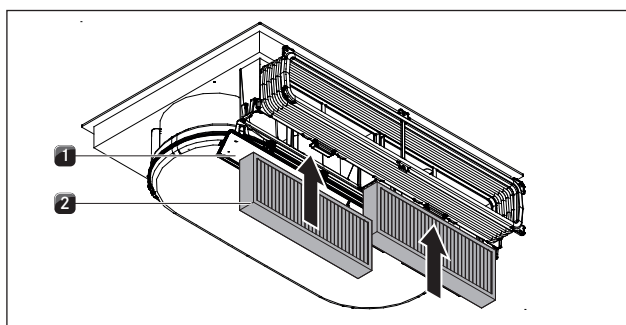

Abb. 6.18 Securing the cooktop in the middle

- [1] Cooktop
- [2] Suction opening
- [3] Air inlet nozzle
- [4] Stainless steel grease filter
- [5] Worktop cut-out
- [6] Mounting bracket

#### For surface mounting

- ▶ Make sure that the sealing tape for the cooktop is flat against the worktop.

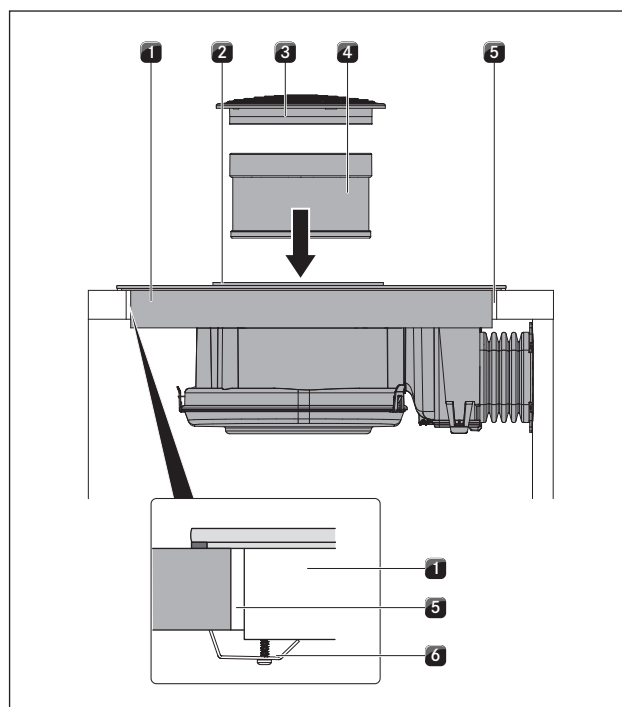
#### For flush installation

- ▶ Make sure that the sealing tape of the cooktop is sealed well all the way round.
- ▶ If applicable, insert the height adjustment plate.
- ▶ Fasten the cooktop to the worktop using the mounting brackets [6].
- ▶ Next, insert the stainless steel grease filter [4] and the air inlet nozzle [3].
- ▶ Seal the surrounding gap with black, heat-resistant silicone sealant.

## 6.6 Installing the exhaust air version (BFIA)

**INFO** The state and regional laws and regulations must be observed with regard to the exhaust duct design. A sufficient air supply must be ensured.

### 6.6.1 Operating the cooktop extractor with a fireplace that depends on the air in the room

Fireplaces that depend on the air in the room (e.g. gas, oil, wood or coal-fired heaters, continuous-flow water heaters, instantaneous water heaters) draw in air from the room in which they are installed and release the exhaust fumes into the outside air via an exhaust system (e.g. chimney).

If the cooktop extractor is used in exhaust mode, it draws in air from the room in which it is installed as well as from neighbouring rooms. If there is insufficient air supply, low pressure will occur. Toxic gases could be drawn out of the chimney or extraction ducting and back into the room.



Abb. 6.19 Exhaust air installation – not permitted



Abb. 6.20 Exhaust air installation – correct

- ▶ If simultaneously operating both a fireplace and the cooktop extractor in the same room, ensure that:
  - the maximum low pressure is 4 Pa ( $4 \times 10^{-5}$  bar);
  - a safety device (e.g. window contact switch, low pressure warning device) is used to ensure that a sufficient supply of fresh air is guaranteed;
  - the exhaust air is not be ducted into a chimney that is used for exhaust gases of devices operated with gas or other combustibles;
  - the installation is checked and approved by an authorised certified engineer (e.g. heating engineer).

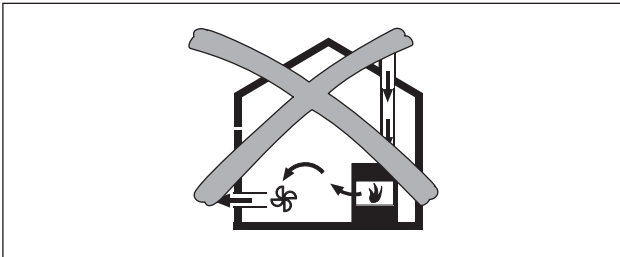
## Installation dimensions

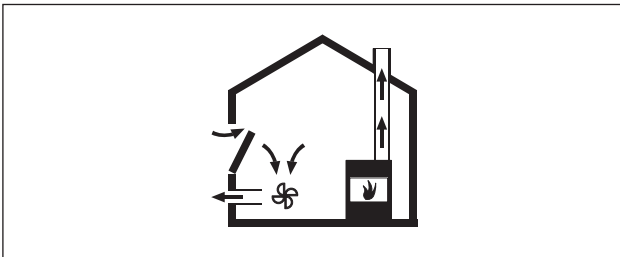

Abb. 6.21 Device dimensions with exhaust air

- [a] Device dimensions without cable extension
- [b] Device dimensions with cable extension

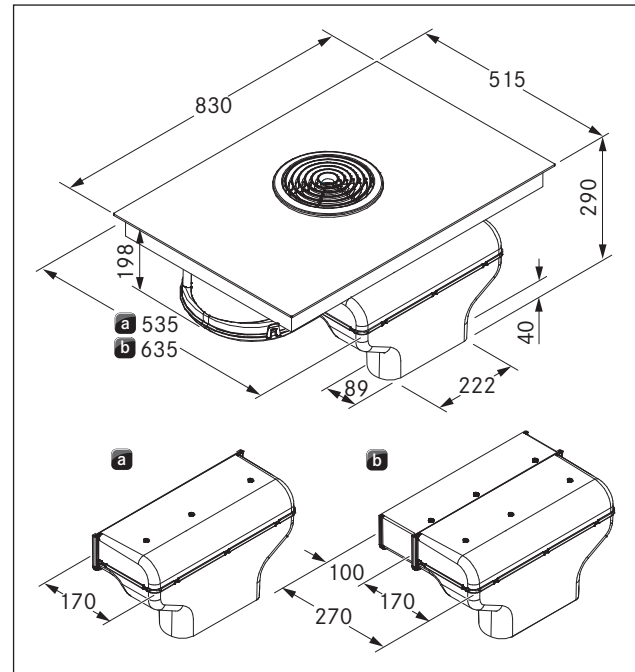

Abb. 6.22 Kitchen unit dimensions with exhaust air

- [a] Worktop depth from 600 mm
- [b] Worktop depth from 700 mm



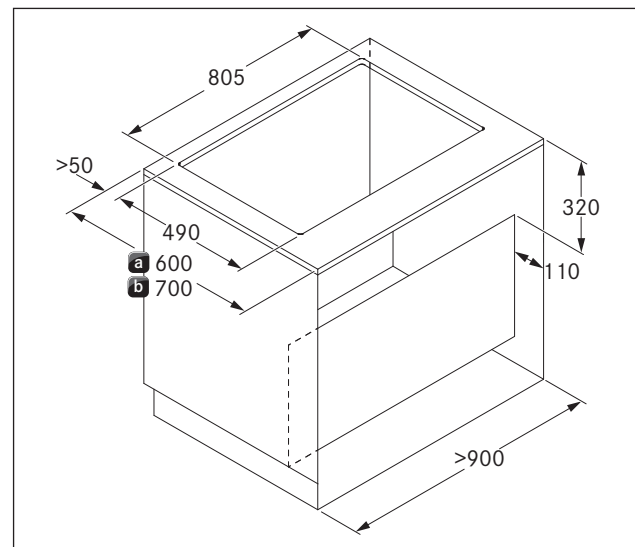

Abb. 6.23 Installation dimensions for exhaust air, worktop depth 600 mm



Abb. 6.24 Installation dimensions for exhaust air, worktop depth from 700 mm

#### Installation conditions

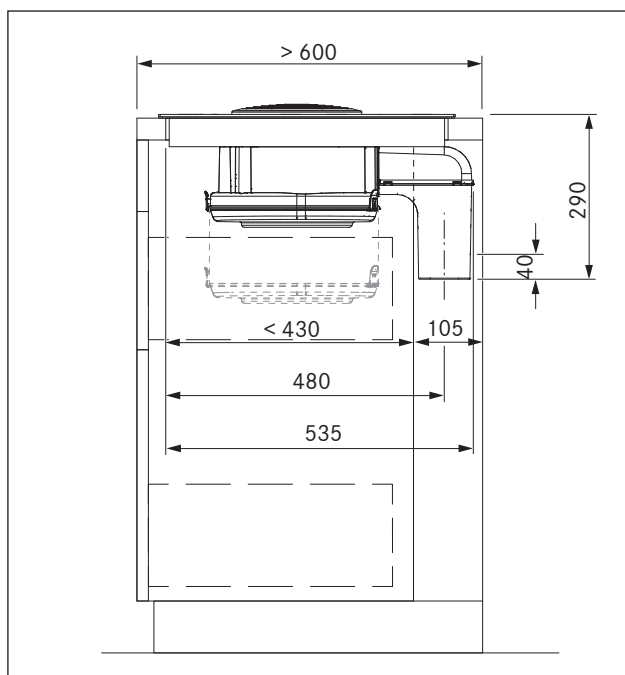
- The back wall of the floor unit must be adjusted for the exhaust air duct.
- A minimum clearance of 110 mm between the back furniture body wall and an adjacent kitchen unit or room wall must be observed for the air duct.
- The exhaust air must be directed to the outside in appropriate exhaust air ducts.
- The minimum cross-section of the air ducts must be 176 cm<sup>2</sup>. This corresponds to a round pipe with a diameter of 150 mm.

- The maximum exhaust air duct length is 6 m.
- Planning instructions for the installation of the exhaust air ducts are provided in the BORA ventilation handbook.

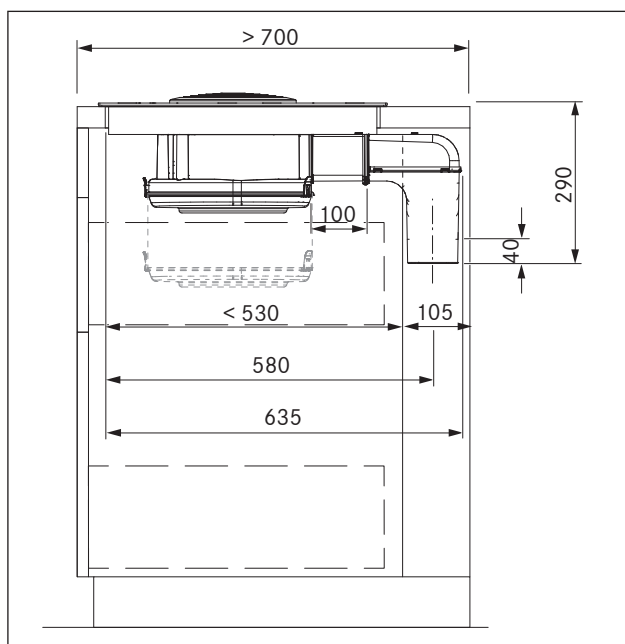
#### Preparing the back wall of the kitchen unit

- ▶ Before installation, check the suitability of floor unit with regard to the necessary installation dimensions for the device and the planned duct system.
- ▶ If necessary, adjust the position of the back wall according to the required installation dimensions.

#### Extending the exhaust air duct

**INFO** The exhaust air duct can optionally be extended by 100 mm to the rear using the supplied horizontal extension BLAVH.

- ▶ Remove the air inlet nozzle and the stainless steel grease filter.
- ▶ Insert the cooktop with the glass ceramic panel facing downward on a clean and soft surface (e.g. cardboard, packaging material) in order to avoid damage to the glass ceramic panel.



Abb. 6.25 Removing the housing base

- [1] Housing base
- [2] Locks
- [3] Air guiding housing

- ▶ Open the 4 locks [2].
- ▶ Remove the housing base [1] from the air guiding housing [3].

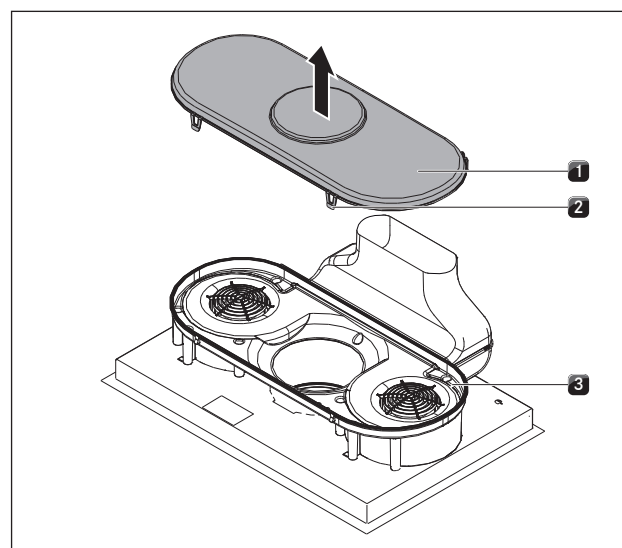

Abb. 6.26 Unlocking the position lock

[1] Shackles for position lock

- Use a screw driver to press the shackles left and right [1] downward to unlock the position lock.

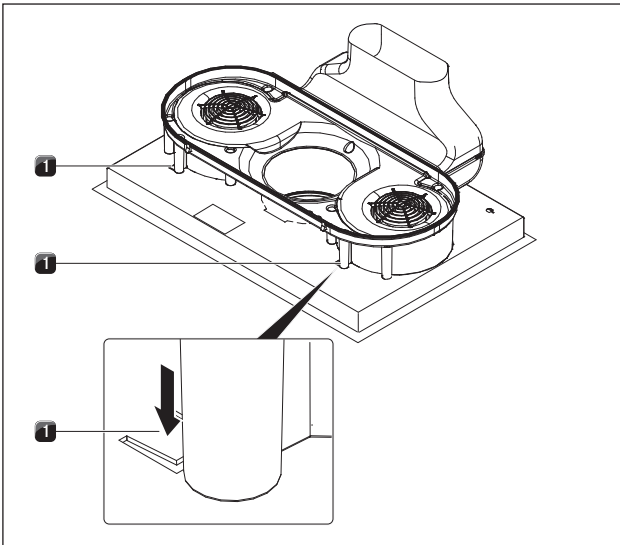

Abb. 6.27 Moving the air guiding housing

[1] Exhaust air arc  
[2] Air guiding housing  
[3] Insertion aperture

- Move the air guiding housing [2] laterally together with the exhaust air arc [1] to the left edge of the insertion aperture [3].

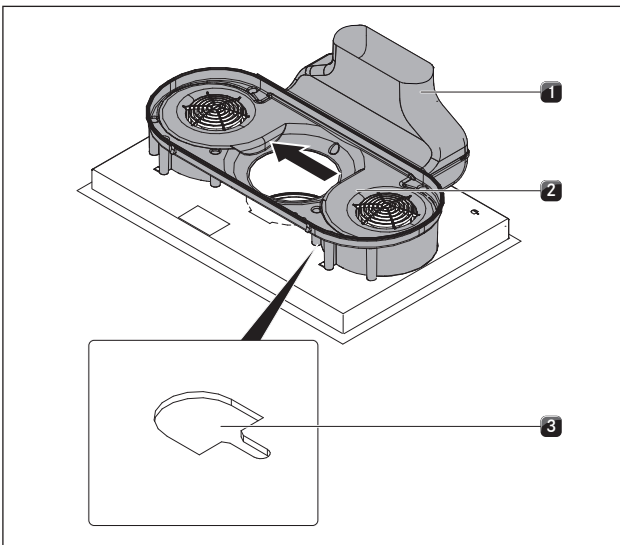

Abb. 6.28 Removing the air guiding housing

[1] Exhaust air arc  
[2] Air guiding housing

- Remove the air guiding housing [2] with the exhaust air arc [1] upward.

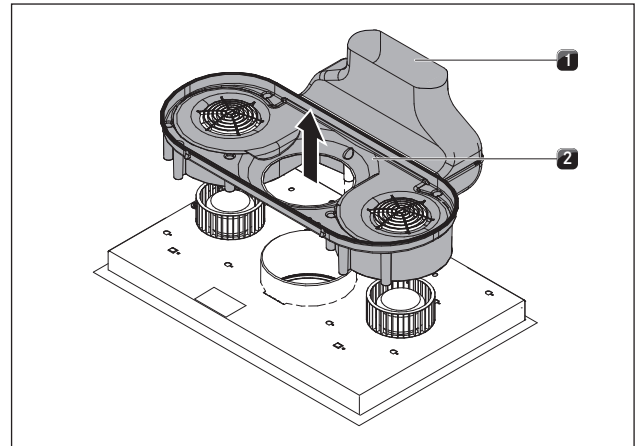

Abb. 6.29 Removing the exhaust air arc

[1] Exhaust air arc  
[2] Air guiding housing

- Remove the exhaust air arc [1] from the air guiding housing [2] upward.

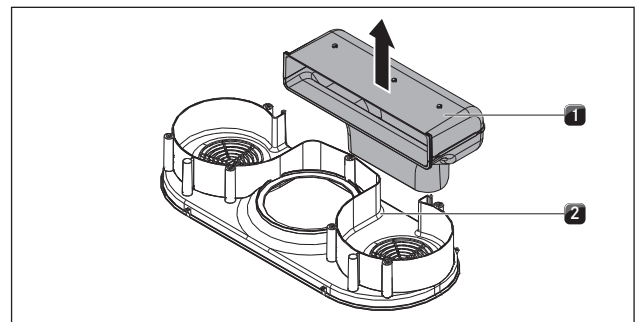

Abb. 6.30 Inserting the air duct extension

[1] Exhaust air arc  
[2] Exhaust air duct extension  
[3] Air guiding housing

- ▶ Insert the exhaust air duct extension [2] into the groove of the air guiding housing [3].
- ▶ Insert the exhaust air arc [1] into the groove of the exhaust air duct extension [2].

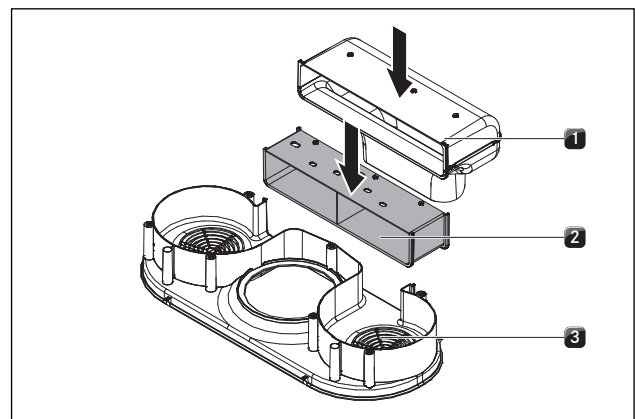

Abb. 6.31 Placing the airflow assembly on the cooktop base

- [1] Airflow assembly
- [2] Openings

- ▶ Position the airflow assembly [1] on the cooktop base in such a way that all retaining hooks fit into the openings [2].

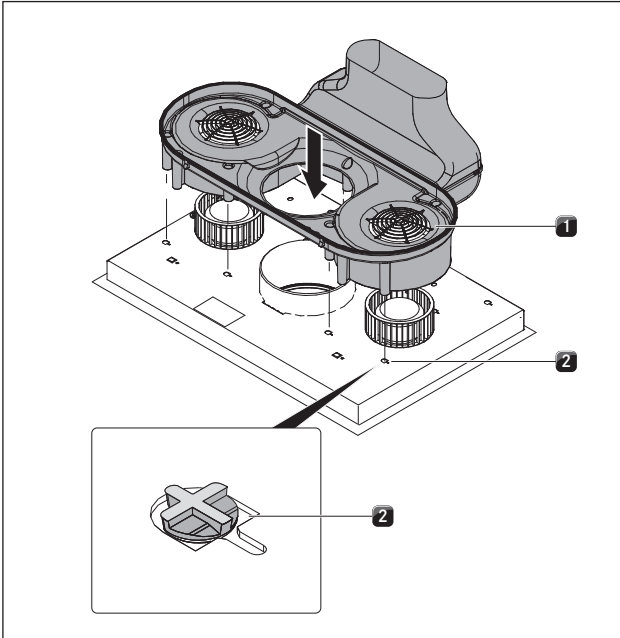

Abb. 6.32 Engaging the airflow assembly

- [1] Airflow assembly
- [2] Openings

- ▶ Now move the airflow assembly [1] to the right until it is fully engaged in the opening slot [2].

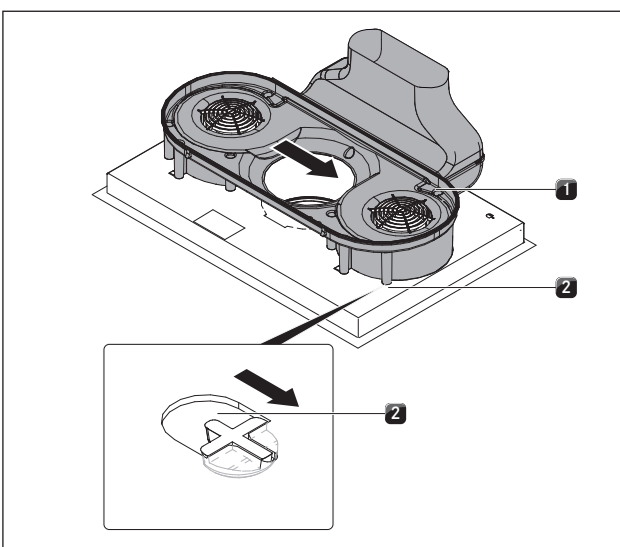

Abb. 6.33 Position lock

- [1] Shackles for transportation and position lock

- ▶ Press the two shackles [1] for the position lock upward.
- ▶ Raise the cooktop with integrated cooktop extractor.
- ▶ Turn the glass ceramic side upward.

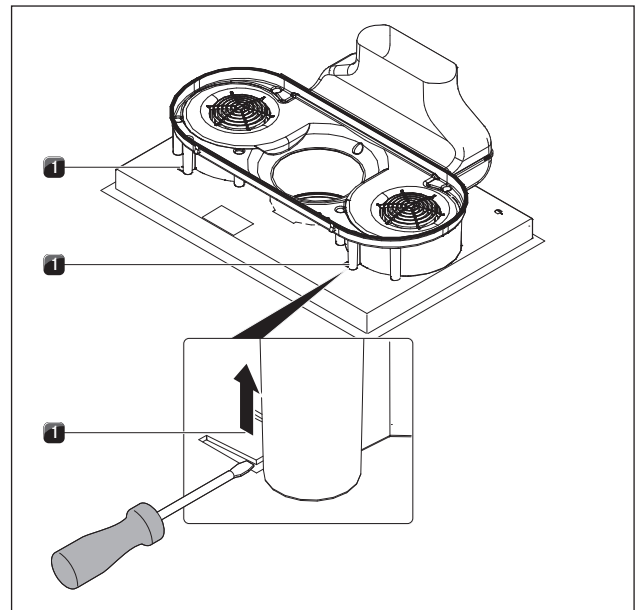

Abb. 6.34 Inserting the cooktop

- [1] Cooktop
- [2] Suction opening
- [3] Air inlet nozzle
- [4] Stainless steel grease filter
- [5] Worktop cut-out

- ▶ Use the suction opening [2] as a handle during insertion.
- ▶ Hold the suction opening [2].
- ▶ Insert the cooktop in the middle of the worktop cut-out [5].

### For surface mounting

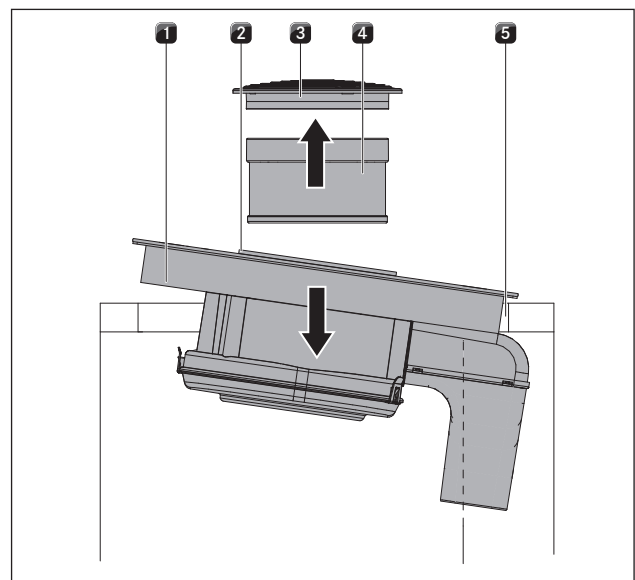
- ▶ Make sure that the sealing tape is resting on the worktop.

### For flush installation

- ▶ Make sure that the sealing tape of the cooktop is sealed well all the way round.
- ▶ If applicable, insert the height adjustment plate.



Abb. 6.35 Connect the air duct

- [1] Mounting bracket
- [1] Exhaust air arc
- [2] Exhaust air duct

- ▶ Connect the exhaust air duct [8] at the installation site to the exhaust air arc [7].
- ▶ Seal the duct connection so that it is airtight using adhesive sealing tape UDB1.
- ▶ Fasten the cooktop to the worktop using the mounting brackets [6].
- ▶ Next, insert the stainless steel grease filter [4] and the air inlet nozzle [3].
- ▶ Seal the surrounding gap with black, heat-resistant silicone sealant.

## 6.7 Establishing the power connection

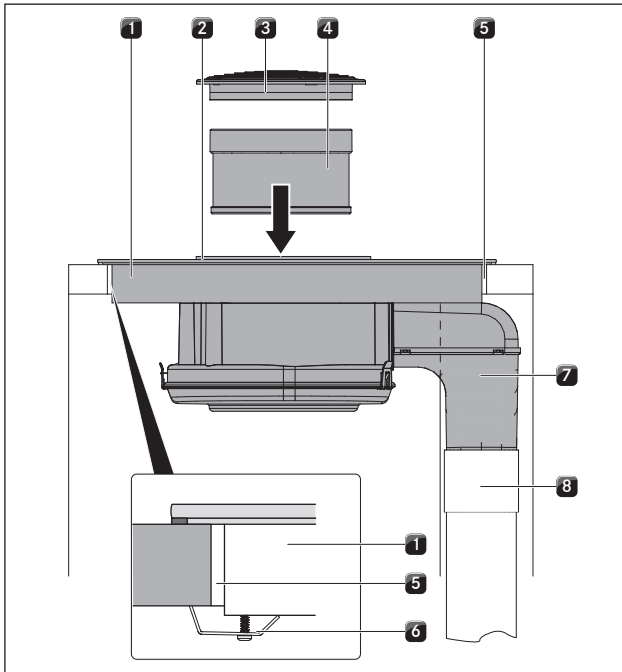
- ▶ Observe all safety and warning information (see the Safety chapter).
- ▶ Observe all national and regional laws and regulations as well as the supplementary regulations of the local utility companies.

**INFO** The power connection may only be established by certified specialists. He/she also assumes responsibility for the proper installation and commissioning.

**INFO** Connections via plug-in contacts (Schuko plugs) are not permitted.

**INFO** The device complies with IEC 61000-3-12

- ▶ Switch off the main switch/automatic circuit breaker before connecting the cooktop.
- ▶ Protect the main switch/automatic circuit breaker from being switched on without permission.
- ▶ Make sure the device is not energised.
- ▶ Connect the cooktop exclusively via a fixed connection to an H 05 VV-F power supply cable with corresponding minimum cross-section (see tab. Fuse protection and minimum cross-section).

Connection	Fuse protection	Minimum cross-section
3-phase connection	3 x 16 A	2.5 mm <sup>2</sup>
2-phase connection	2 x 16 A	2.5 mm <sup>2</sup>
1-phase connection	1 x 32 A	4 mm <sup>2</sup>

Tab. 6.2 Fuse protection and minimum cross-section



Abb. 6.36 Connection diagram 3-phase connection



Abb. 6.37 Connection diagram 2-phase connection

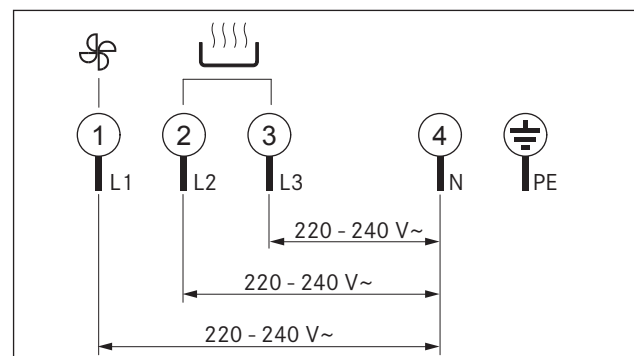

Abb. 6.38 Connection diagram 1-phase connection

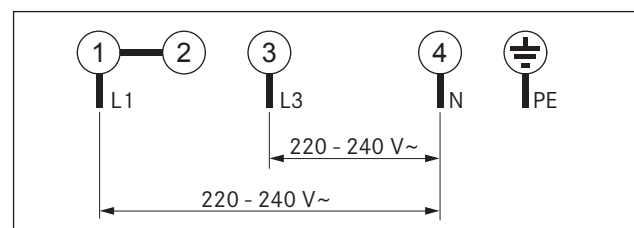

Abb. 6.39 Electrical connections of the cooktop

- [1] Bore holes
- [2] Power supply
- [3] Connection control
- [4] Cable mounting clip

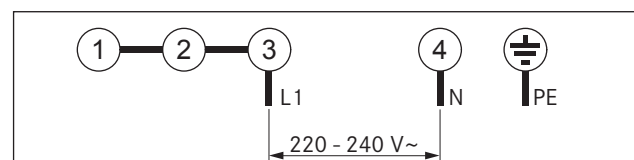
- ▶ Connect the power supply cable to the power supply [2] of the cooktop with cooktopFig. 6.36r in accordance with the relevant connection diagram (see fig. 6.36 Connection diagram).
- ▶ For a 1-phase or 2-phase connection, connect the relevant contacts with the BKAS connector clip (in scope of delivery).
- ▶ Fasten the cable mounting clips [3] to the designated bore holes [1] either on the left or right hand side for the cable routing to the rear.
- ▶ Ensure that the cable is not caught or damaged and is not able to touch any hot hobs.
- ▶ Verify that the installation was done correctly.
- ▶ Switch on the main switch/automatic circuit breaker.
- ▶ Put the cooktop into operation (see the Operation chapter).
- ▶ Check all the functions are working correctly.

## 6.8 Device power management (overall power reduction)

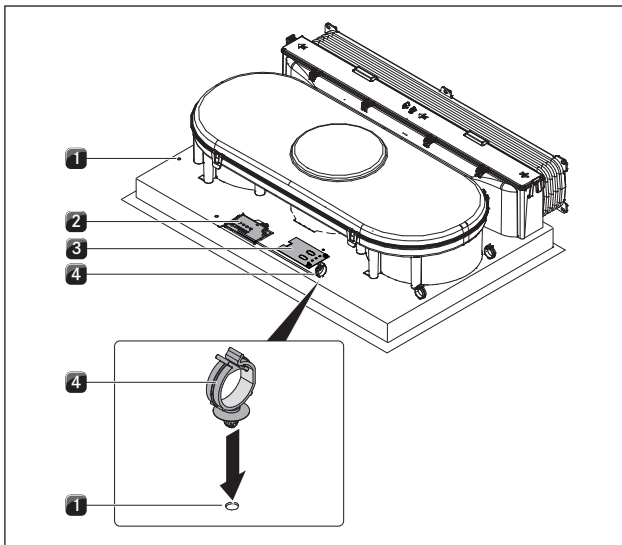
**INFO** The device power management function can be set in the service menu. Accessing the service menu and changing the power management setting may only be performed by a certified specialist.

The total device power can be reduced to 4.4 kW upon initial commissioning if the required electrical power cannot be provided at the installation site. The connection must always be equipped with 20 A fuse protection as a minimum.

### Programming the device power management

#### Prerequisites:

- The cooktop is switched off.
- All cooking zones are switched off.
- ▶ Separate the device from the voltage supply using the LS switch, fuses, automatic circuit breakers or contactors.
- After re-establishing the voltage supply, you have up to two minutes to open the service menu.
- ▶ Re-connect the appliance to the voltage supply.
- ▶ Press and hold the multi-function button.
- ▶ Briefly press the timer button.
- A short signal tone will sound and the front half of the setting ring lights up.
- ▶ Now release the multi-function button.
- ▶ Swipe the setting ring in a circular, clockwise motion to move from 3 to 8.



Abb. 6.40 Opening the service menu

- $\square$  is displayed intermittently with  $\square$  and  $\square$  on the left front cooking zone indicator.
- $\square$  is displayed in the left back cooking zone indicator (factory setting).
- ▶ Use the multi-function button to select the menu level  $\square$ .
- ▶ Press any button on the setting ring to change the setting from  $\square$  to  $\square$ .
- ▶ Press the timer button to save the change.
- The cooktop is ready for use.

Menu setting $\square$	Cooking zone power	
	Left side	Right side
$\square$	3.7 kW	3.7 kW
$\square$	2.2 kW	2.2 kW

Tab. 6.3 Device power management

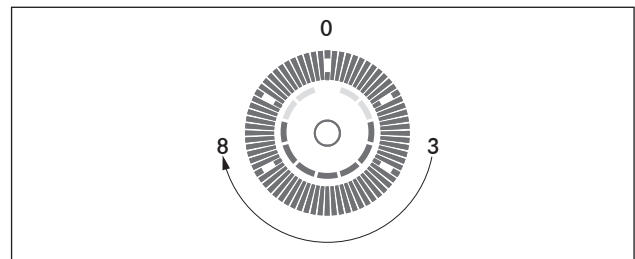
## 6.9 Connect the external switch contact

**INFO** The Home-In and Home-Out communication connection must only be connected by a certified specialist. He/she also assumes responsibility for the proper installation and commissioning.

When using Home-In and Home-Out, you will require the relevant documents for the external switching devices in order to ensure safe device connection and operation.

The following switch connections can be used:

Contact	Function	Connection
Home-In	Cooktop extractor on/off connection for external switch contact (contact closed: cooktop extractor on)	30 V DC 0.7 mA
Home-Out	Electrically isolated contact for controlling external installations depending on the operation of the cooktop extractor (cooktop extractor on: contact closed)	Maximum 250V/4A

Tab. 6.4 Home-In and Home-Out switch connections

**INFO** The Home-In contact can be used for external safety devices (e.g. window contact switches). If the switch is open, the cooktop extractor is out of operation.



Abb. 6.41 Opening the cover and disconnecting the contact plug

- [1] Cover
- [2] Electronic unit
- [3] Contact plug

- ▶ Open the cover [1].
- ▶ Adhere to the connection diagram when connecting Home-In and Home-Out.
- ▶ Disconnect the contact plug [3] from the electronic unit [2].

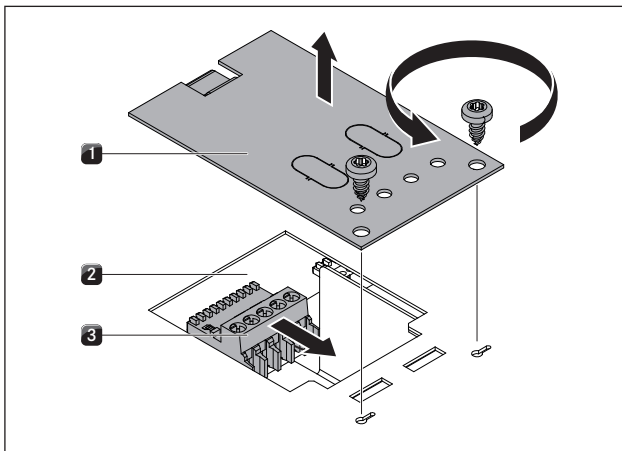

Abb. 6.42 External switch contacts connection diagram



Abb. 6.43 Connecting the cable

- [1] Sealing cover
- [2] Cover
- [3] Cable opening
- [4] Protective hose
- [5] Electronic unit
- [6] Contact plug
- [7] Cable connection

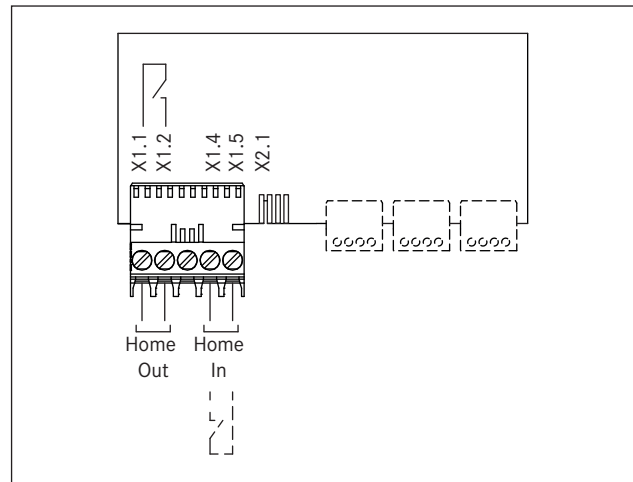
- ▶ Remove the sealing cover [1] for the cable opening [3] with a screw driver.
- ▶ Move the protective hose [4] onto the cable [7].
- ▶ Guide the cable [7] with the protective hose [4] through the cable opening [3] in the cover.
- ▶ Remove the installed bridge.
- ▶ Connect the cable for the relevant contact to the contact plug [6] in accordance with the relevant connection diagram (see fig. Connection diagram for external switch contacts).

**INFO** The Home-In contact must be bridged if this is not used (bridged on delivery).

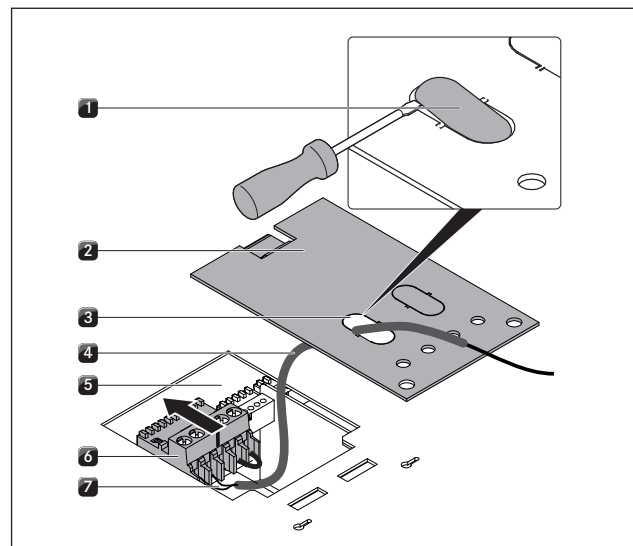
- ▶ Connect the contact plug [6] to the electronic unit [5].
- ▶ Ensure that the protective hose [4] is located directly on the contact plug [6] and that the protective hose [4] goes through the opening [3] in the cover [2].



Abb. 6.44 Attaching tension relief

- [1] Cover
- [2] Cable opening
- [3] Protective hose
- [4] Cable tie

- ▶ Attach the cable tie [4] to the cover [1].  
However, do not yet tighten the cable tie.
- ▶ Avoid tension on the cable.
- ▶ Close the cover [1].
- ▶ Tighten the cable tie [4] (tension relief).
- ▶ Ensure that the cable is not caught or damaged and is not able to touch any hot hobs.
- ▶ Verify that the installation was done correctly.
- ▶ Switch on the main switch/automatic circuit breaker.
- ▶ Put the cooktop extractor into operation (see the Operation chapter).
- ▶ Check all the functions are working correctly.

## 6.10 Handover to user

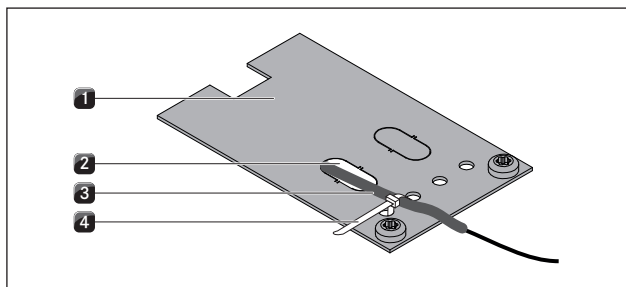
Once installation is done:

- ▶ Explain the important functions to the user.
- ▶ Explain all safety-relevant aspects of operation and handling to the user.
- ▶ Provide the user with the accessories and operating and installation instructions to be kept in a safe place.

## 7 Operation

- ▶ Observe all safety and warning information during operation (see the Safety chapter).

**INFO** Only operate the cooktop if the stainless steel grease filter and the air inlet nozzle have been installed.

### 7.1 General operating instructions

The cooktop or cooktop extractor is operated using the operating panel.

The selection of the cooking zone is performed by the direct selection of the assigned sensor button on the operating panel.

There are 9 power levels and one power setting available for each cooking zone and the cooktop extractor.

The selection on the setting ring is performed by direct selection or by uniformly swiping clockwise or anti-clockwise.



Abb. 7.1 Setting ring with power level positions

### 7.2 Operating the cooktop

#### Switching on

**INFO** If the display shows  $\square$  and no other input is made, the device will switch off automatically after 20 seconds.

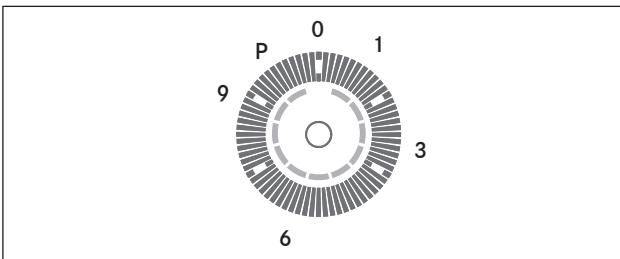
- ▶ Press the on/off switch  $\text{I}$  to switch on the device.
- The power level  $\square$  is shown on the display.

#### Switching off

**INFO** Use the operating panel to switch off the cooking zone after use. Do not rely on the pan size recognition.

- ▶ Press the on/off switch  $\text{I}$  to switch off the device.
- ▶ Pay attention to the residual heat display (see the Device Description chapter).

#### 7.2.1 Select cooking zone

- ▶ Press the cooking zone button for the desired cooking zone.
- The  $\square$  in the cooking zone indicator lights up more brightly.

#### 7.2.2 Adjusting the power level

- ▶ Press the desired power level or
- ▶ Press and uniformly swipe round the setting ring until the desired power level is reached.

#### 7.2.3 Changing the power level

- ▶ Press the cooking zone button for the desired cooking zone.
- The cooking zone indicator lights up more brightly.
- ▶ Select the desired power level.

#### 7.2.4 Selecting the power setting

- ▶ Press the cooking zone button for the desired cooking zone.
- The cooking zone indicator lights up more brightly.
- ▶ Select power setting  $P$ .
- The power setting  $P$  is displayed in the cooking zone indicator.

#### 7.2.5 Switching the power setting off early

- ▶ Press the cooking zone button for the desired cooking zone.
- The cooking zone indicator lights up more brightly.
- ▶ Select another power level.
- The current power level is displayed in the cooking zone indicator and the power setting is deselected.

#### 7.2.6 Switching off the cooking zone

- ▶ Press the cooking zone button for the desired cooking zone.
- The cooking zone indicator lights up more brightly.
- ▶ Press the power level position  $\square$ .
- ▶  $\square$  will appear on the display for a few seconds, then the display will turn off.

#### 7.2.7 Pay attention to the residual heat display

After switching it off, the cooking zone remains hot.  $H$  is displayed in the cooking zone indicator (residual heat display). The cooking zone indicator will go out after sufficient cooling time (temperature < 60°C).

**Info** While  $H$  is displayed in the cooking zone indicator (residual heat display), do not touch the cooking zone or place any heat-sensitive objects on top of it. Risk of burns and fire!

- ▶ Pay attention to the residual heat display.
- ▶ Be careful not to touch or place objects on hot hobs.



## 7.2.8 Pause function

### Switching on the pause function

#### Prerequisite

- At least one cooking zone is in use.

**INFO** The pause function switches off automatically after 10 minutes.

- ▶ Press and hold the multi-function button  for approx. 2-3 seconds.
- If there is no input, the display will turn off after 5 seconds.
- ▶ Swipe the setting ring in a circular, clockwise motion to move from 1 to P.





Abb. 7.2 Switching on the pause function

- The segments are displayed on the circular display in accordance with the position.
- **||** appears in all the cooking zone indicators and two short successive beeps confirm activation.
- The pause function is activated.
- The cooktop extractor remains in operation at a lower power level.

### Switching off the pause function

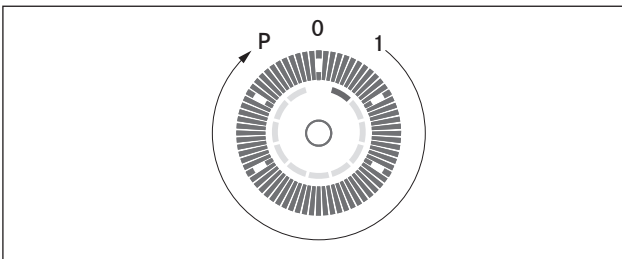
- ▶ Press the multi-function button .
- If there is no input for 10 seconds, the pause function will continue.
- The setting ring will show the last segment.
- ▶ Swipe the setting ring in a circular, anticlockwise motion to move from P to 1.



Abb. 7.3 Switching off the pause function

- The segments are displayed on the circular display in accordance with the position.
- All displays will show the power level that was originally set.
- The pause function is deactivated.

## 7.2.9 Bridging function

If the bridging function is active, two cooking zones will operate at the same time on the same cooking level. The front cooking zone will also control the rear, bridged cooking zone.

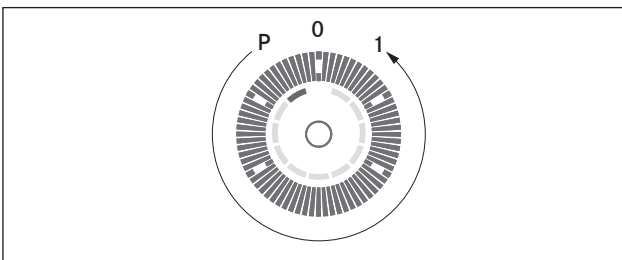
### 7.2.10 Switching on the bridging function

#### Prerequisite

- The cooktop is switched on.
- All cooking zones are switched off.
- ▶ Select the front cooking zones and hold down the cooking zone selection button.
- After 2 seconds, the rear cooking zone indicator will show **||** and there will be a beep.
- ▶ Press the cooking zone selection button for the rear cooking zone to activate the bridging function.
- ▶ Set a power level on the front cooking zone within 3 seconds.
- The bridging function is activated and the rear cooking zone indicator shows **||**.
- If there is no input within 3 seconds, the bridging function will end.

### 7.2.11 Switching off the bridging function

- ▶ Switch the power level of the front cooking zone to **0**.
- After 3 seconds, the bridging function is deactivated.

### 7.2.12 Automatic heat up function

#### Switching on the automatic heat up function

#### Prerequisite

- The cooktop is switched on.
- A cooking zone is switched on.
- ▶ The automatic heat up function is activated if you press and hold the desired continuous cooking level (1 to 8) for 2 seconds.
- The cooking zone indicator will display the symbol **||** to show that the automatic heat up function is activated, as well as the continuous cooking level set, for example **5**.

#### Changing the automatic heat up function

The power level of the continuous cooking level can be changed within 15 seconds of activation.

- ▶ Select the cooking zone.
- ▶ Select the desired power level.
- ▶ The selected continuous cooking level, e.g. **7**, appears in the cooking zone indicator.



After the end of the automatic heat up function (see the Device Description chapter), the cooking session will continue with the desired continuous cooking level, e.g. **7**.

### 7.2.13 Switching off the automatic heat up function

The activated automatic heat up function will end prematurely if you

- ▶ change the power level;
- ▶ activate the power setting P;
- ▶ activate the heat retention level  $\cup$ ;
- ▶ switch off the cooktop using the on/off switch .

### 7.2.14 Heat retention level

- The cooktop is switched on.
- ▶ Select a cooking zone.
- ▶ Press the multi-function button  several times to increase the heat retention level.
- The cooking zone indicator will display the relevant heat retention level, e.g.  $\cup$ .
- ▶ Press the multi-function button  again.
- The heat retention level is deactivated.
- The cooking zone will automatically switch off after 8 seconds.

### 7.2.15 Using the timer function

**Info** The relevant timer control light shows whether the timer is activated. The timer control light lights up until the cooking zone has automatically switched off after the pre-set time has passed.

#### Prerequisite

- The cooktop is switched on.

You can use 2 timer functions:

- Short-time timer (egg timer – cooking zone does not switch off automatically).
- Automatic cut-off (for automatically switching off a cooking zone).

You can set a time range of between 1 and 99 minutes for both timer functions.

**INFO** After the end of the time set, 00 will appear in the time display for a few seconds and the dot in the display or the relevant timer control light will flash. A signal tone will sound for a few seconds.

- The signal tone and the flashing are automatically deactivated after 2 minutes.

### 7.2.16 Switching the signal beep off early

- ▶ Press any sensor button on the operating panel to end the signal tone prematurely.

### 7.2.17 Setting the short-time timer (egg timer)

- ▶ Press the timer button .
- 00 will appear in the timer display for a few seconds and the dot below the display will flash.

- If there is no input, the timer display will turn off after 10 seconds.

- ▶ Press the timer button  multiple times to increase the duration by +10 minutes each time.
- ▶ Change the minutes in the timer display by making a selection on the setting ring.
- Once the desired time has been selected, the timer starts automatically.

### 7.2.18 Switching off the short-time timer (egg timer) early

You can switch off the short-time timer early by

- ▶ changing the remaining timer setting to  $\cup\cup$ .



### 7.2.19 Setting the automatic cut-off

You can set an automatic cut-off for every cooking zone.

**INFO** If several cooking zones are activated with an automatic cut-off, the lowest timer value will be shown and the timer control light for the cooking zone in question will light up more brightly.

#### Prerequisite

- A cooking zone has been selected.
- A power level was set.

- ▶ Select the desired cooking zone.
- ▶ Press the timer button  within 3 seconds.
- 00 will appear in the timer display for a few seconds and the dot next to the display will flash.
- ▶ Press the timer button  multiple times to increase the duration by 10 minutes each time.
- ▶ Change the minutes in the timer display by making a selection on the setting ring.
- Once the desired time has been selected, the timer starts automatically.

After the last input, the set time will be displayed in the timer display for a few seconds.

### 7.2.20 Switching off the automatic cut-off early

The activated automatic cut-off function will end early if you

- ▶ change the remaining timer setting to  $\cup\cup$ ;
- ▶ switch off the cooktop using the on/off switch .
- ▶ Change the power level to 0.

### 7.2.21 Changing the timer settings

- ▶ Press the cooking zone button for the cooking zone for which you wish to change the automatic cut-off.
- ▶ Press the timer button  multiple times to increase the duration by 10 minutes each time.
- ▶ Change the minutes in the timer display by uniformly swiping the setting ring.

### 7.2.22 Switching the childproofing feature on/off

**INFO** If a cooking zone indicator alternates between displaying **L** and **H**, the cooking zone is still hot.

#### Switching on the childproofing feature

##### Prerequisites:

- The cooktop is switched on.
- All cooking zones are switched off.
- ▶ Press and hold the multi-function button  for approx. 2-3 seconds.
- If there is no input, the display will turn off after 5 seconds.
- ▶ Swipe the setting ring in a circular, clockwise motion to move from 1 to P.





Abb. 7.4 Switching on the childproofing feature

- The segments are displayed on the circular display in accordance with the position.
- **L** is displayed in all cooking zone indicators.
- The childproofing feature is activated.

#### Switching off the childproofing feature

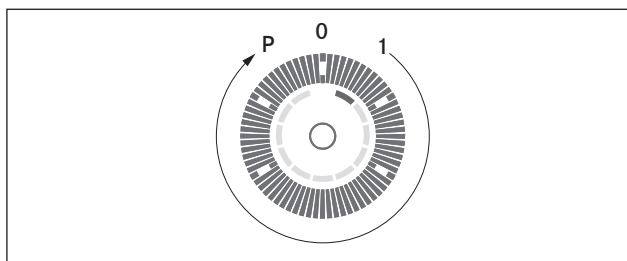
- The cooktop is switched on.
- ▶ Press and hold the multi-function button  for approx. 2-3 seconds.
- The setting ring will show the last segment.
- ▶ Swipe the setting ring in a circular, anticlockwise motion to move from P to 1.



Abb. 7.5 Switching off the childproofing feature

- The segments are displayed on the circular display in accordance with the position.
- All cooking zone indicators display **A**.
- The childproofing feature is deactivated.

The power level you require can now be set for each cooking zone.

## 7.3 Operating the cooktop extractor

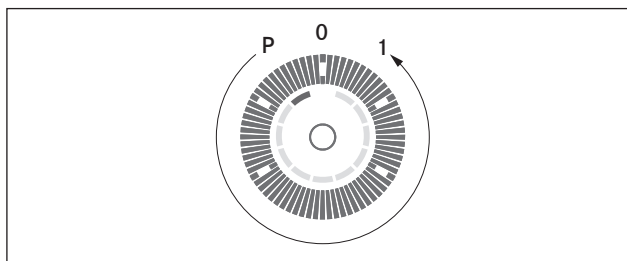
### Prerequisite:

- The cooktop with integrated cooktop extractor is switched on.

### Recommendations for efficient vapour extraction:

- ▶ Always use a lid on pots that are particularly high. This ensures effective vapour extraction. It also reduces power consumption.
- ▶ Only operate the cooktop extractor at the minimum power level required for an effective vapour extraction. This enables you to improve the performance of the odour filters in recirculation mode.
- ▶ Only operate the hob at the minimum power level required for cooking. This reduces the cooking vapours and the power consumption.
- ▶ Avoid strong drafts.

### 7.3.1 Selecting a cooktop extractor

- ▶ Press the selection button for the cooktop extractor.
- The **A** in the cooking zone indicator lights up more brightly.

### 7.3.2 Adjusting the power level

- ▶ Press the desired position on the setting ring to set the power level or
- ▶ Press and uniformly swipe round the setting ring until the desired power level is reached.

### 7.3.3 Changing the power level

- ▶ Press the selection button for the cooktop extractor.
- The fan display lights up more brightly.
- ▶ Select the desired power level.
- The set power level is displayed in the fan display.

### 7.3.4 Selecting the power setting

- ▶ Press the selection button for the cooktop extractor.
- The fan display lights up more brightly.
- ▶ Select power setting **P**.
- The power setting **P** is displayed in the cooking zone indicator.
- The power setting **P** automatically switches to power level **A** after 10 minutes.

### 7.3.5 Automatic cooktop extractor function

**INFO** If the automatic cooktop extractor function is activated, the power level can be changed. The automatic cooktop extractor function will be reactivated after 10 minutes.

- ▶ Press the selection button for the cooktop extractor.
- ▶ Press the multi-function button .
- The fan display lights up more brightly.
- The automatic cooktop extractor function is activated.
- **A** appears on the display.

### 7.3.6 Switching off the automatic cooktop extractor function

- ▶ Press the selection button for the cooktop extractor.
- ▶ Press the multi-function button .
- The automatic cooktop extractor function is deactivated.

### 7.3.7 Automatic after-run

- ▶ Press the selection button for the cooktop extractor.
- The fan display lights up more brightly.
- ▶ Select power level .
- The power level  $n$  is shown on the display.
- The cooktop extractor switches off automatically after 20 minutes.

### 7.3.8 Switching off the automatic after-run early

- ▶ Press the selection button on the cooktop extractor while the automatic after-run is active.
- The automatic after-run is switched off.

### 7.3.9 Switching off the cooktop extractor

- ▶ Press the selection button for the cooktop extractor.
- The fan display lights up more brightly.
- ▶ Select power level .
- The power level  $n$  is shown on the display.
- ▶ Press the selection button for the cooktop extractor again.
- The device switches off.

or

- ▶ Press the on/off switch  to switch off the device.

## 7.4 Pay attention to the filter service display

If  $F$  appears on the fan display, this means the service life of the activated charcoal filter has expired (with recirculation only) and the stainless steel grease filter needs to be thoroughly cleaned:

- ▶ Press the selection button for the cooktop extractor.
- ▶ Press any button.
- $F$  is shown in the fan display.



The filter service display is shown every time the cooktop extractor is switched on and remains active until the filter has been changed and the filter service display is reset. The cooktop extractor can still be operated without limitations.

### Changing the filter

- ▶ Switch off the cooktop with integrated cooktop extractor.
- ▶ Observe all warnings that are described in the Cleaning chapter.
- ▶ Replace the activated charcoal filter.
- ▶ Clean the stainless steel grease filter, the air inlet nozzle, the air guiding housing and the housing base.

### Resetting the filter service display

If the activated charcoal filter has been replaced (with recirculation only) and the stainless steel grease filter has been cleaned, it will be necessary to reset the filter service display.

- ▶ Switch on the cooktop with integrated cooktop extractor.
- The fan display will show a flashing  $F$ .
- ▶ Press the selection button on the cooktop extractor for at least 4 seconds until a flashing  appears. After a few seconds, a solid  will be displayed.
- The filter service display has been reset.

## 7.5 Saving energy

- ▶ Follow all of the energy-saving tips to use the cooktop with integrated cooktop extractor in an energy-efficient manner.
- ▶ When purchasing cookware, pay attention to the diameter of the base as the upper diameter of the pot is usually specified. The diameter of the base is often smaller.
- ▶ Use pressure cookers. Due to the closed cooking chamber and the overpressure, these save a great deal of time and energy. The short cooking time also helps preserve vitamins.
- ▶ Make sure there is sufficient liquid in the pressure cooker. An empty pot which is still being heated can lead to overheating. This can damage both the cooking zone and the pot.
- ▶ If possible, always seal cookware using a suitable lid.
- ▶ Choose a suitable size of cookware for the amount of food you are cooking. A big pot that is barely filled requires a lot of energy.

## 8 Cleaning and maintenance

- ▶ Observe all safety and warning information (see Safety chapter).
- ▶ Follow the enclosed manufacturer's information.
- ▶ Make sure that the cooktop and cooktop extractor have been switched off completely and have cooled down prior to the planned cleaning and maintenance work to prevent injury (see the Operation chapter).
- Regular cleaning ensures the longevity of the product and optimal functioning.
- ▶ Adhere to the following cleaning and maintenance cycles:

Component	Cleaning cycle
Operating panel	Immediately after every soiling
Cooktop	Immediately after every soiling every week thoroughly with standard commercially available glass ceramic cleaners
Cooktop extractor	Weekly
Air inlet nozzle and stainless steel grease filter	After every time you prepare very greasy foods; at least weekly, when the fan level indicator = $F$ by hand or in the dishwashing machine (at a max. 65 °C); Only clean the stainless steel surfaces in the polishing direction!
Air guiding housing	Clean every 6 months or when replacing the activated charcoal filter
Activated charcoal filter (only for recirculated air)	Replace after the build-up of odour, when the extraction power has diminished or the fan level indicator shows $F$

Tab. 8.1 Cleaning cycles

### 8.1 Cleaning agents

**INFO** Due to the use of aggressive cleaning agents and abrasion caused by the pot bases the surface will become damaged and dark stains will occur.

You need a special glass ceramic panel scraper and suitable cleaning agents to clean the cooktop.

- ▶ Never use steam cleaners, abrasive sponges, scouring pads, or chemically aggressive cleaning agents (e.g. baking oven spray).
- ▶ Make sure that the cleaning agent does not contain any sand, soda, acids or chloride.

#### For air inlet nozzle and grease filter

- ▶ Do not use any aggressive, acidic or alkaline cleaning agents.

### 8.2 Maintaining the cooktop

- ▶ Do not use the cooktop as a worktop or shelf.
- ▶ Do not push or pull cookware across the cooktop.
- ▶ Always lift pots and pans.
- ▶ Keep the cooktop clean.
- ▶ Remove any kind of soiling immediately.
- ▶ Only use cookware which is suitable for glass ceramic panels (see the Device description chapter)

### 8.3 Cleaning the cooktop

**INFO** When the cooktop extractor is switched on, the air inlet nozzle is installed to ensure that no small and light objects, such as cleaning wipes made of fabrics or paper are sucked in.

- ▶ Make sure that the cooktop is switched off (see Operating chapter).
- ▶ Wait until all cooking zones are cold.
- ▶ Remove all coarse soiling and food residues from the cooktop with a glass ceramic scraper.
- ▶ Apply the cleaning agent onto the cold cooktop.
- ▶ Rub the cleaning agent with a paper towel or a clean cloth.
- ▶ Wipe off the cooktop while wet.
- ▶ Rub the cooktop dry with a clean cloth.

#### When the cooktop is hot:

- ▶ Immediately remove molten residues of plastic, aluminium film, sugar or foods containing sugar with a glass ceramic scraper from the hot cooking zone to prevent burning them in.

#### Special soiling

- ▶ Heavy soiling and stains (limescale stains, pearly shimmering stains) are best to be removed if the cooktop is still warm.
- ▶ Soften dried dirt residues using a damp cloth.
- ▶ Remove dirt residues with the glass ceramic scraper.
- ▶ Always remove grains, crumbs or the like which fall onto the cooktop during general cooking work right away to prevent the surface from being scratched.

Coloured changes and shiny surfaces are not cooktop damage. They do not impact on the function of the cooktop and the stability of the glass ceramic.

Discolourations to the cooktop arise from residues which are not removed and have been burnt in.

Glossy spots are caused by the abrasion of the pot base, especially when using cooking utensils with aluminium bases, or by unsuitable cleaning agents. They are very hard to remove.

## 8.4 Cleaning the cooktop extractor

The air inlet nozzle and the stainless steel grease filter absorb the greasy components of the kitchen vapour.

- ▶ Make sure that the cooktop and cooktop extractor are switched off (see Operating chapter).
- ▶ Wait until the fan display is 0.
- ▶ Clean the cooktop extractor in accordance with the cleaning cycles (see Tab. 7.1).
- ▶ Clean the surfaces of the exhaust air system using a soft damp cloth, detergent or a mild window cleaning agent.
- ▶ Soften dried-on dirt residues using a damp cloth (do not scratch!).

### 8.4.1 Removing the air inlet nozzle and stainless steel grease filter



Abb. 8.1 Removing the air inlet nozzle

- [1] Air inlet nozzle
- [2] Access opening

**Prerequisite:** The fan level indicator indicates 0.

- ▶ Reach into the access opening [2] with your hand.
- ▶ Remove the air inlet nozzle [1] out upwards.

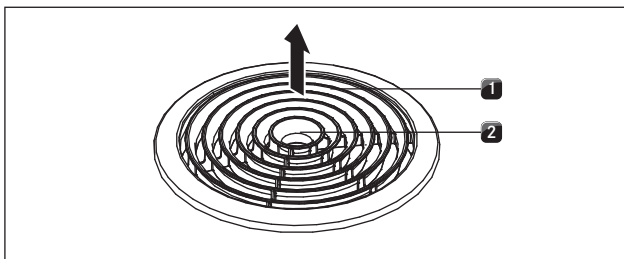

Abb. 8.2 Removing the stainless steel grease filter

- [1] Stainless steel grease filter
- [2] Handle
- [3] Suction opening

- ▶ Grab the stainless steel grease filter using the handle [2].
- ▶ Pull the stainless steel grease filter [1] out of the suction opening [3] upwards.

### 8.4.2 Cleaning the air inlet nozzle and stainless steel grease filter

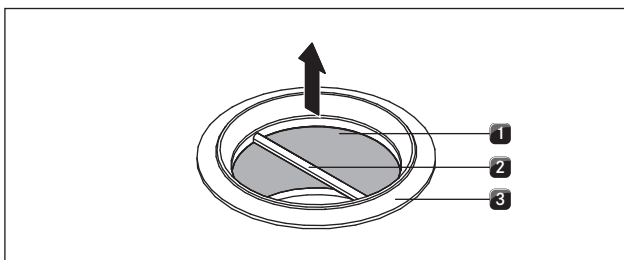
**INFO** Clean the stainless steel surfaces in the polishing direction only.

**INFO** If the stainless steel grease filter can no longer be cleaned completely, this means the stainless steel grease filter will need to be replaced.

#### Manual cleaning

- ▶ Use a degreasing cleaning agent.
- ▶ Rinse the inlet nozzle and stainless steel grease filter with hot water.
- ▶ Use a soft brush to clean the inlet nozzle and stainless steel grease filter.
- ▶ After cleaning, rinse the inlet nozzle and stainless steel grease filter well.

#### Cleaning in the dishwasher

- ▶ Rinse the air inlet nozzle and the stainless steel grease filter with a rinsing program at a maximum of 55 °C.

### 8.4.3 Installing stainless steel grease filter and air inlet nozzle

- ▶ Grab the stainless steel grease filter using the handle [2] (Fig. 7.2)
- ▶ Insert the stainless steel grease filter [1] into the suction opening.
- ▶ Make sure that the stainless steel grease filter rests against the bottom housing base. A lock is not needed and is not provided.
- ▶ Reach into the access opening [2] of the inlet nozzle with your hand (Fig. 7.1).
- ▶ Insert the air inlet nozzle (Fig. 7.1; [1]) centrally into the suction opening.
- ▶ Press the air inlet nozzle upwards until it engages.

## 8.5 Cleaning the air guiding housing

Greasy deposits and limescale residues from the cooking vapour can accumulate on the surface of the air guiding housing. Regular, thorough cleaning (see Table 7.1) is thus necessary.

The air guiding housing is on the underside of the cooktop in the floor unit.

### 8.5.1 Opening the air guiding housing

- ▶ Make sure that the cooktop and cooktop extractor are switched off (see Operating chapter).
- ▶ Wait until the fan display is 0.



Abb. 8.3 Opening the air guiding housing

- [1] Front locks
- [2] Air guiding housing
- [3] Housing base
- [4] Rear locks

- ▶ Hold the housing base with one hand [3].
- ▶ Open both locks on the rear [4].
- ▶ Open both front locks [1].
- ▶ Remove the housing base [3].
- ▶ Clean the air guiding housing [2] and the housing base [3] with a mild cleaning agent.

### 8.5.2 Closing the air guiding housing

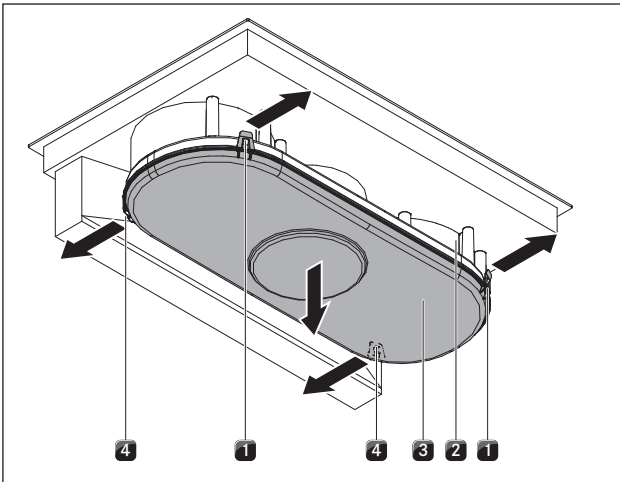

Abb. 8.4 Closing the air guiding housing

- [1] Air guiding housing
- [2] Sealing groove
- [3] Hooks
- [4] Locking stop
- [5] Housing base

- ▶ Using both hands, position the housing base [5] so that the position of the locking straps [4] on the housing base match the position of the hooks [3] on the housing.
- ▶ Insert the housing base at the sealing groove [2] of the air guiding housing [1].
- ▶ Press the housing base [5] upwards until the 4 locks (2 front, 2 rear) engage into the hooks [3].
- ▶ Check that all 4 locking straps [4] have correctly engaged.

## 8.6 Replacing the activated charcoal filter

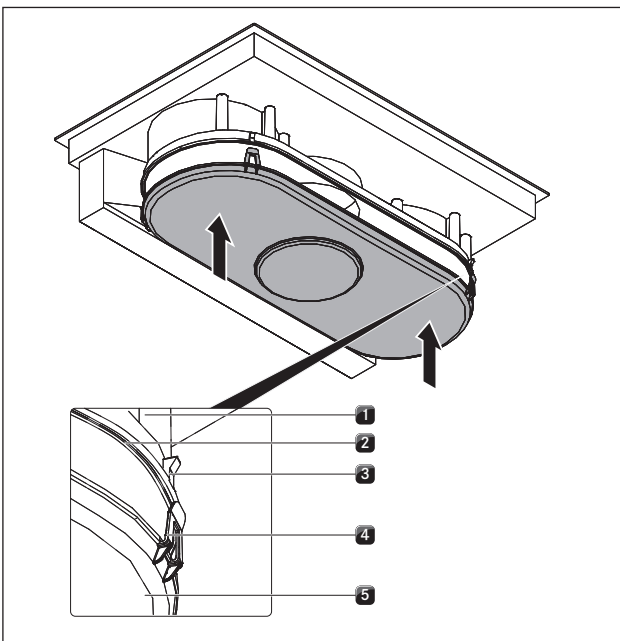
Two activated charcoal filters are used only when the cooktop extractor is being operated in recirculated air mode. The activated charcoal filter binds odorous materials which arise during cooking.

**INFO** The activated charcoal filters must be replaced when the fan level indicator indicates  $F$  (filter service display). BAKF activated charcoal filters can be purchased from your specialist. You can also contact BORA on its homepage <http://www.bora.com>.

- ▶ Make sure that the cooktop and cooktop extractor are switched off (see Chapter 6.1).
- ▶ Wait until the fan display is  $\square$ .



Abb. 8.5 Releasing the activated carbon filter housing lid

- [1] Outer locks
- [2] Activated carbon filter housing cover
- [3] Middle lock

### Removing the activated carbon filter

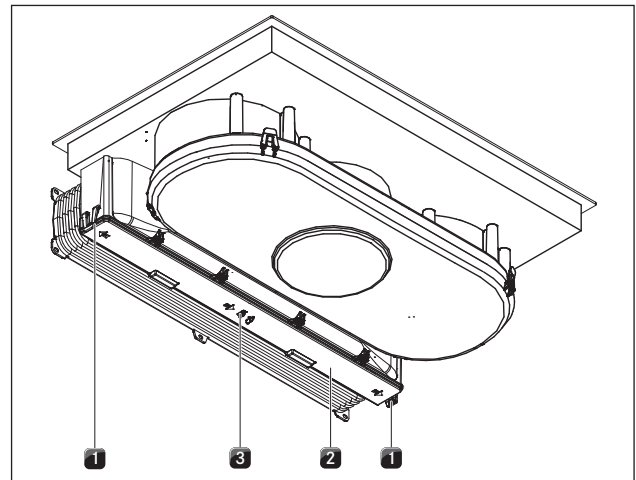

Abb. 8.6 Opening middle lock

[1] Lock, middle

- ▶ Open the lock [1] in the middle.

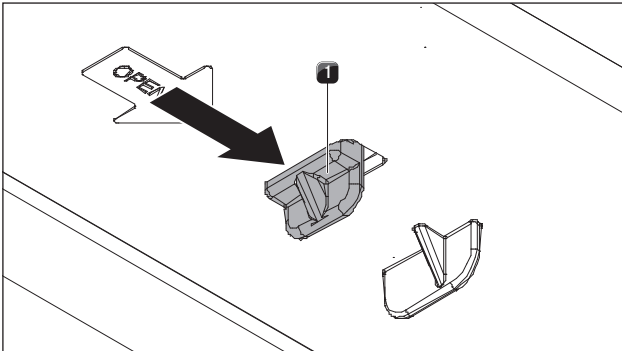

Abb. 8.7 Opening outer locks

[1] Outer lock

- ▶ Open both outer locks [1].
- ▶ Fold the lid (Fig. 7.5; [2]) down until it engages.

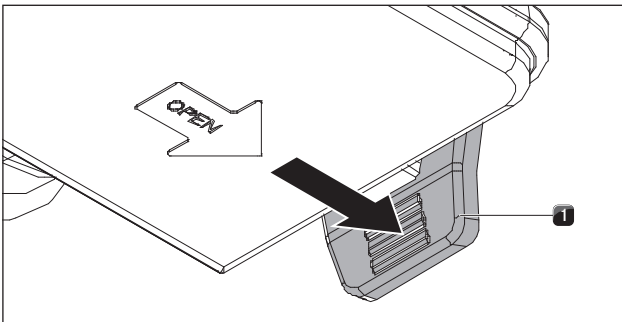

Abb. 8.8 Removing the activated carbon filter

[1] Activated charcoal filter  
[2] Filter bracket

- ▶ Hold the activated charcoal filter with one hand [1].
- ▶ Push the filter retainer [2] to the back.

- ▶ Remove the activated charcoal filter by moving it downwards.
- ▶ Dispose of used activated charcoal filters with household waste.

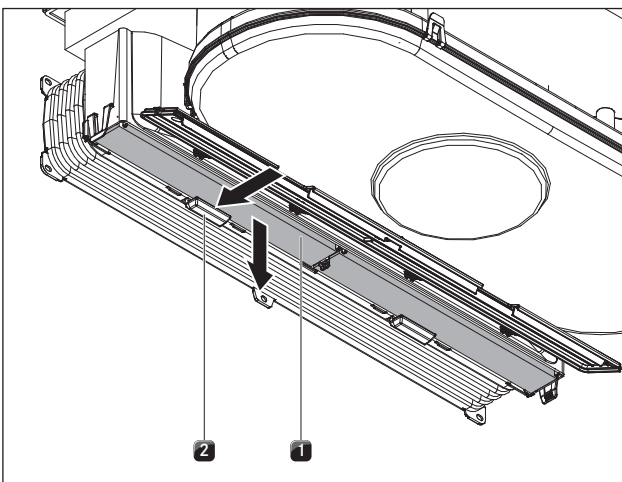
### Inserting the activated charcoal filter



Abb. 8.9 Inserting the activated charcoal filter

[1] Filter bracket  
[2] Activated charcoal filter

- ▶ Position the new activated charcoal filter [2] in such a way that the directional arrow is pointing to the rear and is visible from below.
- ▶ Move the activated charcoal filter into the housing.
- ▶ Press the activated charcoal filter upwards until the filter retainer [1] engages.

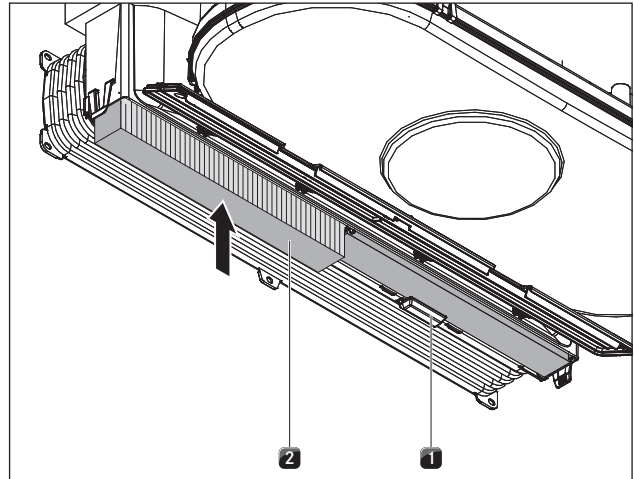

Abb. 8.10 Closing the activated charcoal filter housing lid

[1] Locks  
[2] Activated carbon filter housing cover

- ▶ Fold the activated charcoal filter housing lid [2] by moving up upwards.
- ▶ Press on the activated charcoal filter housing lid until the locks [1] engage.

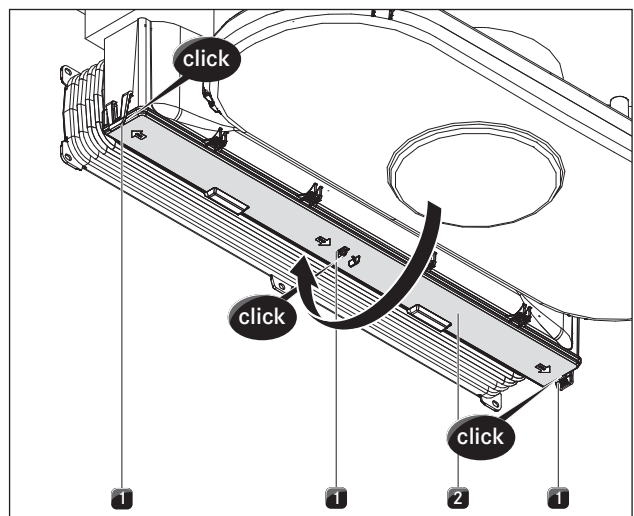

## 9 Troubleshooting

Operating situation	Cause	Remedy
The cooktop or the fan cannot be switched on.	The fuse or the automatic circuit breaker of the electrical installation of the apartment and/or house is defective.	Replace the fuse. Switch the automatic circuit breaker back on.
	The fuse or the automatic circuit breaker trips several times.	Call the BORA Service Team.
	The power supply is disconnected.	Have a specialist electrician inspect the power supply.
Odours and vapours arise when the new cooktop is put into operation.	This is normal on brand-new appliances.	Wait a few operating hours. Contact the Service Team if the odour persists.
$\perp$ is displayed in the cooking zone indicator.	No or unsuitable cookware has been placed on the cooking zone.	Only use suitable cookware. Select the cookware size depending on the cooking zone (see the Device Description chapter).
$\perp$ is displayed in the cooking zone indicator.	The childproofing feature is activated.	Switch off the childproofing feature (see the Operation chapter).
A cooking zone or the entire cooktop switches off automatically.	The operating time of a cooking zone has been exceeded.	Put the cooking zone back into operation (see the Operation chapter).
	The overheating protection has tripped.	(see the Device Description chapter)
The power setting is automatically shut off prematurely.	The overheating protection has tripped.	(see the Device Description chapter)
$E_{-}03$ is shown across all 4 cooking zone indicators and the cooktop switches off during operation.	One or more sensor buttons are covered, e.g. due to finger contact or by objects placed on them.	Clean the operating panel or remove objects (see the Device description chapter).
The cooling fan continues running after the cooktop has been switched off.	The cooling fan will continue to run until the cooktop has cooled down and will then switch off automatically.	Wait until the cooling fan switches off automatically.
$E$ is displayed in the cooking zone indicator.	An error has occurred in the electronic system.	Interrupt the cooktop power supply for approx. 1 minute. If the problem continues to persist after the power supply has been restored, write down the error number and contact the BORA Service Team.
$F$ is displayed in the fan level indicator.	The period of use of the filters has been exceeded.	Replace the activated charcoal filter (with recirculation only) and thoroughly clean the stainless steel grease filter. In case of heavy soiling, replacing the stainless steel grease filter is also recommended (see Cleaning and maintenance chapter).
The extraction performance of the cooktop extractor has decreased.	The stainless steel grease filter is heavily soiled.	Clean or replace the stainless steel grease filter.
	The activated charcoal filter is heavily soiled (BFU only).	Replace the activated charcoal filter.
	There is an object in the air guiding housing (e.g. cleaning cloth).	Remove the trapped object.
$E_{-}B1$ or $E_{-}B2$ is shown in the fan level indicator.	The fan is defective or a duct connection has become loose.	Call the BORA Service Team.
$E$ is displayed in the fan level indicator. The fan cannot be switched on.	The Home-In contact is broken.	When using a window contact switch (safety device), the window must be open when the fan is operating.
	The safety device is defective.	Call the BORA Service Team.

Tab. 9.1 Resolving a fault

► In all other instances, call the BORA Service Team (see the Warranty, service and spare parts chapter).

## 10 Decommissioning, disassembly and disposal

- ▶ Observe all safety and warning information (see Safety chapter).
- ▶ Follow the enclosed manufacturer's information.

### 10.1 Decommissioning

Decommissioning is considered the final decommissioning and disassembly. After decommissioning, the device can either be built into another piece of furniture, sold on privately, or disposed of.

---

**INFO** Disconnecting and connecting the electricity and gas connection may only be carried out by certified experts.

---

- ▶ Switch off the device before decommissioning (see Operating chapter)
- ▶ Disconnect the device from the voltage supply.

### 10.2 Disassembly

The removal requires that the device is accessible for disassembly and was separated from the voltage supply. On gas-powered devices, make sure that the gas connection is complete.

- ▶ Undo the mounting brackets.
- ▶ Remove the silicone joints.
- ▶ Disconnect the duct from the cooktop extractor.
- ▶ Remove the device from the worktop upwards.
- ▶ Remove further accessory parts.
- ▶ Remove the old appliance and dirty accessory as described under "Disposing of the product in an environmentally friendly way".

### 10.3 Disposing of the product in an environmentally friendly way

#### Disposal of transport packaging

---

**INFO** The packaging protects the device against transport damages. The packaging is made of materials that are environmentally friendly and easy to dispose of and can therefore be recycled.

---

Returning the packaging material into the material cycle saves resources and reduces the waste production. Your specialist supplier will take the packaging back.

- ▶ Hand the packaging to your specialist supplier or
- ▶ Dispose of the packaging properly taking into account the regional regulations.

#### Disposing of the old appliance



Electrical devices marked with this symbol should not be disposed of as household waste at the end of its life. They must be taken to a collection centre for recycling electrical or electronic non-heating appliances. For information, please contact your city or local authorities.

Waste electric and electronic equipment often still contains valuable materials. They do, however, also contain harmful substances that were required for their correct functioning and safety. When disposed of in the residual waste or if not handled correctly, they may cause harm to the health of people and the environment.

- ▶ Therefore do not dispose of your old appliance as household waste.
- ▶ Take the old appliance to a regional collection centre for return and recycling of electronic and electrical parts and other materials.

# 11 Warranty, service and spare parts

- ▶ Observe all safety and warning information (see Safety chapter).

## 11.1 Warranty

The warranty period shall be 2 years.

## 11.2 Service

### BORA Service:

see reverse side of operating and assembly instructions



- ▶ In the case of faults you cannot fix yourself, contact your BORA specialist supplier or the BORA Service Team.

The After Sales Service will require the type designation and the serial number of your device (FD number). This information is provided on the nameplate or on the back of the manual as well as on the device.

## 11.3 Spare parts

- ▶ Only use original spare parts when making repairs.

---

**INFO** Spare parts can be obtained from your BORA dealer, the BORA online service website at [www.bora.com/service](http://www.bora.com/service) or by calling the service number provided.

---

**Nameplate:**

**Germany::**

**BORA Lüftungstechnik GmbH**  
Rosenheimer Str. 33  
83064 Raubling  
Germany  
T +49 (0) 8035 / 907-240  
F +49 (0) 8035 / 907-249  
info@bora.com  
www.bora.com

**Australia – New Zealand:**

**BORA APAC Pty Ltd**  
A/ 91-95 Victoria Road  
Drummoyne NSW 2047  
Australia  
T +61 2 7900 5580  
F +61 2 8076 3514  
info@boraapac.com.au  
www.boraapac.com.au

**Austria:**

**BORA Vertriebs GmbH & Co KG**  
Prof.-Dr.-Anton-Kathrein-Straße 3  
6342 Niederndorf  
Österreich  
T +43 (0) 5373 / 62250-0  
F +43 (0) 5373 / 62250-90  
mail@bora.com  
www.bora.com

**Europe:**

**BORA Holding GmbH**  
Prof.-Dr.-Anton-Kathrein-Straße 3  
6342 Niederndorf  
Austria  
T +43 (0) 5373 / 62250-0  
F +43 (0) 5373 / 62250-90  
mail@bora.com  
www.bora.com

