

# LSESW / LSEMG / LSEMG



Stars pendant light built-in – black

Stars pendant light built-in – moss green

Stars pendant light built-in – rose gold

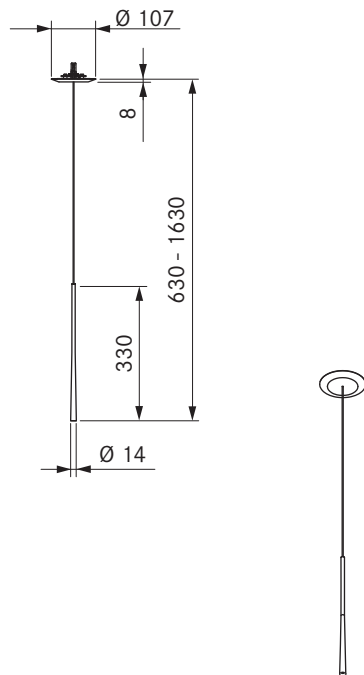

## Technical data

Lighting type	pendant light
Supply voltage	220 - 240 V
Frequency	50 - 60 Hz
Maximum power consumption	4,6 W
Connection clamp	2 pin
Dimmable	no
Bulb	LED
Light colour	warm white
Colour temperature	2700 K
Colour rendering index (Ra)	CRI > 90
Lux	230 lm
Direct beam angle	45°
Service life	> 50000 h
Switching cycles	min. 50000
Surface material	metal / plastic
Protection class	3
Protection rating	IP 20
Ceiling housing dimensions (D x H)	107 x 8 mm
Light dimensions (D x H)	14 x 330 mm
Weight (incl. accessories/packaging)	1,2 kg

## Product description

- Flush installation

## Scope of delivery

- Stars pendant light built-in
- Operating and installation instructions
- Control gear LED driver SK II

## Product- and planning instructions

- LSE can be integrated into a lighting control system using a suitable control gear (not included)