

**EN** Operating and installation instructions BFIAS (BFIA, BFIU)

BORA Basic induction-glass-ceramic-cooktop with cooktop  
extractor – exhaust/recirculation

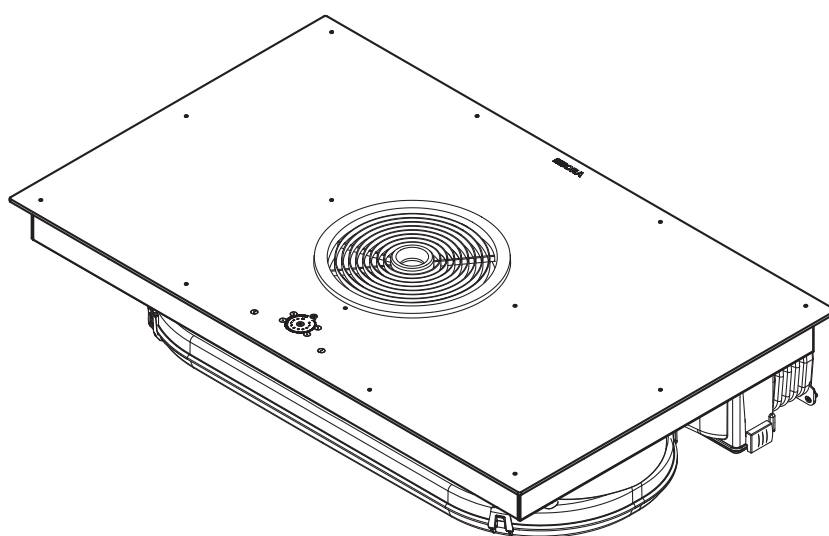
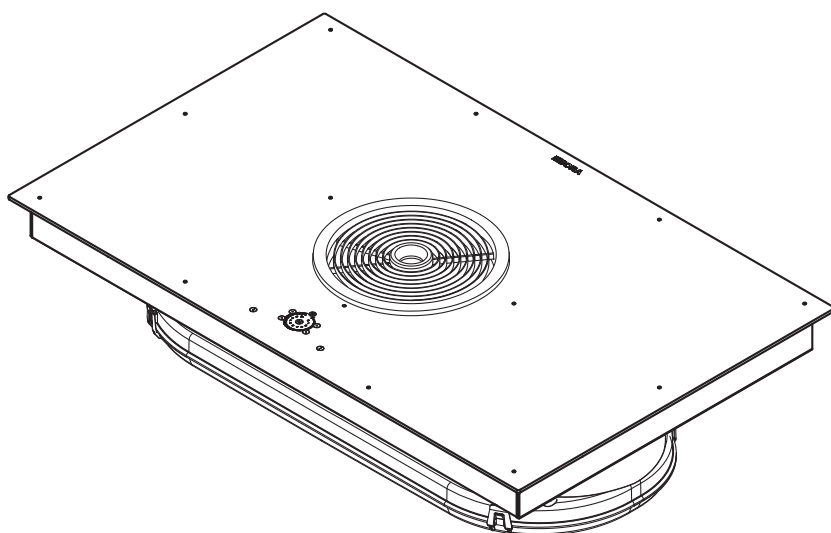

**BFIASUMEN-005**

**Operating and installation instructions:**

Original

Translation

**Manufacturer**

**BORA Vertriebs GmbH & Co KG**

Innstraße 1  
6342 Niederndorf  
Austria

Contact

T +43 (0) 5373 / 62250-0  
mail@bora.com  
www.bora.com

The distribution and duplication of this document, as well as the use and disclosure of its contents are prohibited unless expressly authorised.

These operating and installation instructions have been drawn up with the greatest of care. But it cannot be ruled out that subsequent technical modifications have not yet been incorporated or the relevant content has not yet been adapted. Please accept our apologies in this eventuality. An updated version can be requested from the BORA Service Team. Subject to printing errors and mistakes.

© BORA Vertriebs GmbH & Co KG

All rights reserved.

# Table of Contents

<b>1</b>	<b>General information</b>	<b>4</b>	7.2.1	Select cooking zone.....	33
1.1	Target group.....	4	7.2.2	Adjusting the power level .....	33
1.2	Validity of the operating and installation instructions .....	4	7.2.3	Changing the power level .....	33
1.3	Other applicable documents.....	4	7.2.4	Selecting the power setting.....	33
1.4	Presentation of information .....	5	7.2.5	Switching the power setting off early .....	33
<b>2</b>	<b>Safety</b>	<b>6</b>	7.2.6	Switching off the cooking zone.....	33
2.1	General safety instructions .....	6	7.2.7	Pay attention to the residual heat display .....	33
2.2	Safety instructions – Cooktop operation.....	7	7.2.8	Pause function .....	34
2.3	Safety instructions – Cooktop extractor.....	8	7.2.9	Bridging function.....	34
2.4	Safety Instructions – Installation .....	9	7.2.10	Switching on the bridging function.....	34
2.5	Safety instructions – Cleaning and Maintenance ..	10	7.2.11	Switching off the bridging function.....	34
2.6	Safety instructions – disassembly and disposal....	11	7.2.12	Automatic heat up function .....	34
2.7	Safety instructions – spare parts.....	11	7.2.13	Switching off the automatic heat up function .....	35
2.8	Use as intended .....	11	7.2.14	Heat retention level.....	35
<b>3</b>	<b>Technical data</b>	<b>12</b>	7.2.15	Using the timer function .....	35
<b>4</b>	<b>Energy label</b>	<b>14</b>	7.2.16	Switching the signal beep off early.....	35
<b>5</b>	<b>Device description</b>	<b>15</b>	7.2.17	Setting the short-time timer (egg timer).....	35
5.1	Structure .....	15	7.2.18	Switching off the short-time timer (egg timer) early.....	35
5.2	Operating panel and operating principle .....	16	7.2.19	Setting the automatic cut-off.....	35
5.3	Functional principle of the cooking zone.....	17	7.2.20	Switching off the automatic cut-off early.....	35
5.3.1	Power levels .....	17	7.2.21	Changing the timer settings.....	35
5.3.2	Automatic heat up function .....	17	7.2.22	Switching the childproofing feature on/off .....	36
5.3.3	power setting .....	17	7.3	Operating the cooktop extractor .....	36
5.3.4	Heat retention levels.....	17	7.3.1	Selecting a cooktop extractor.....	36
5.3.5	Bridging function.....	18	7.3.2	Adjusting the power level .....	36
5.3.6	Pause function .....	18	7.3.3	Changing the power level .....	36
5.3.7	Timer functions .....	18	7.3.4	Selecting the power setting.....	36
5.3.8	Pan size recognition.....	18	7.3.5	Automatic cooktop extractor function.....	36
5.3.9	Suitable cookware.....	18	7.3.6	Switching off the automatic cooktop extractor function .....	37
5.4	Functional principle of the cooktop extractor .....	18	7.3.7	Automatic after-run.....	37
5.4.1	Freely adjustable power control .....	18	7.3.8	Switching off the automatic after-run early .....	37
5.4.2	Automatic cooktop extractor function.....	18	7.3.9	Switching off the cooktop extractor .....	37
5.4.3	Power setting.....	19	7.4	Pay attention to the filter service display .....	37
5.4.4	Automatic after-run.....	19	7.5	Saving energy.....	37
5.4.5	Filter service display .....	19	<b>8</b>	<b>Cleaning and maintenance</b>	<b>38</b>
5.4.6	Interface communication.....	19	8.1	Cleaning agents .....	38
5.5	Safety devices.....	19	8.2	Maintaining the cooktop .....	38
5.5.1	Residual heat display .....	19	8.3	Cleaning the cooktop.....	38
5.5.2	Safety shut-down .....	19	8.4	Cleaning the cooktop extractor .....	39
5.5.3	Overheating protection .....	19	8.4.1	Removing the air inlet nozzle and stainless steel grease filter .....	39
5.5.4	Automatic switch-off if the button is pressed and held .....	19	8.4.2	Cleaning the air inlet nozzle and stainless steel grease filter .....	39
5.5.5	Childproofing feature .....	19	8.4.3	Installing stainless steel grease filter and air inlet nozzle .....	39
<b>6</b>	<b>Installation</b>	<b>20</b>	8.5	Cleaning the air guiding housing.....	39
6.1	Checking the scope of delivery.....	20	8.5.1	Opening the air guiding housing .....	39
6.2	Tool and aids.....	20	8.5.2	Closing the air guiding housing.....	40
6.3	Assembly instructions.....	20	8.6	Replacing the activated charcoal filter .....	40
6.3.1	Safety distances.....	20	<b>9</b>	<b>Troubleshooting</b>	<b>42</b>
6.3.2	Worktop and kitchen units.....	20	<b>10</b>	<b>Decommissioning, disassembly and disposal</b>	<b>43</b>
6.4	Cut-out dimensions for the cooktop.....	21	10.1	Decommissioning.....	43
6.5	Attaching the sealing tape .....	21	10.2	Disassembly .....	43
6.6	Installing the recirculation version (BFIU).....	22	10.3	Environmentally-friendly disposal .....	43
6.7	Installing the exhaust air version (BFIA) .....	25	<b>11</b>	<b>Warranty, technical service, spare parts, accessories</b>	<b>44</b>
6.7.1	Operating the cooktop extractor with a fireplace that depends on the air in the room.....	25	11.1	BORA manufacturer's warranty .....	44
6.8	Establishing the power connection.....	29	11.1.1	Warranty extension .....	44
6.9	Device power management (overall power reduction).....	30	11.2	Service .....	44
6.10	Connect the external switch contact.....	31	11.3	Spare parts.....	44
6.11	Handover to user .....	32	11.4	Accessories.....	45
<b>7</b>	<b>Operation</b>	<b>33</b>			
7.1	General operating instructions.....	33			
7.2	Operating the cooktop.....	33			

# 1 General information

## 1.1 Target group

These operating and installation instructions apply for the following target groups:

Target group	Requirements
User	The appliance can be used by children aged 8 and above as well as people with reduced physical, sensory or mental capacities or a lack of experience and/or knowledge if they are supervised or have been instructed how to safely use the appliance and understand the resultant risks. Children must be supervised. All safety and warning information and the handling instructions in the installation instructions must be complied with.
Ambitious DIYers	Ambitious DIYers can independently conduct all joinery and installation work providing they possess the necessary skills and expertise. They must never independently establish electricity and gas connections.
Installation specialists	Installation specialists are authorised to conduct all joinery and installation work in line with existing regulations. The electricity and gas connections must be certified by a certified engineer for the applicable trade prior to commissioning.
Electricians	The electrical connection may only be established by a certified engineer. He/she also assumes responsibility for the proper electrical installation and commissioning.
Gas specialists	The gas connection may only be established by certified engineers. They also assume responsibility for proper installation and commissioning of the gas system.

Tab. 1.1 Target groups

---

**INFO** BORA Holding GmbH, BORA Vertriebs GmbH & Co KG, BORA APAC Pty Ltd and BORA Lüftungstechnik GmbH - hereinafter referred to as BORA - do not assume any liability for damage arising from non-adherence to these documents and from improper assembly! The electricity and gas connections must be made by a qualified specialist. Installation must comply with the valid standards, regulations and laws. All safety and warning information and the operating and installation instructions must be complied with.

---

## 1.2 Validity of the operating and installation instructions

These instructions apply to several device versions. It is therefore possible that some of the features described do not apply to your appliance.

## 1.3 Other applicable documents

These operating and installation instructions are valid in conjunction with other documents, which must be adhered to.

Please be sure to adhere to all documents that form part of the scope of delivery.

---

**INFO** BORA accepts no liability for damage caused by failure to comply with these documents!

---

## Directives

This device meets the following EU/EC directives:

2014/30/EU EMC Directive

2014/35/EU Low Voltage Directive

2009/125/EC Ecodesign Directive

2010/30/EU Energy Consumption Label Directive

2011/65/EU RoHS Directive

2012/19/EU WEEE Directive

## 1.4 Presentation of information

To make working with these instructions quick and easy, consistent formatting, numbering, symbols, safety instructions, terms and abbreviations are used throughout.

**Handling instructions are marked with an arrow.**

- ▶ Always carry out handling instructions in the sequence shown.

**Bullet points are indicated by a square bullet point at the edge of the line.**

- Bullet point 1
- Bullet point 2

---

**INFO** Information points out specific points you must always comply with.

---

### Safety and warning information

The safety and warning information in these instructions are highlighted with symbols and signal words.

Safety and warning information is structured as follows:



---

#### WARNING SYMBOL AND SIGNAL WORD!

- Type and source of the danger
  - Consequences of non-compliance
  - ▶ Measures to minimise risk
- 

The following applies:

- The warning symbol draws attention to the danger.
- The signal word indicates the severity of the risk.

Warning sign	Signal word	Hazard
	<b>Danger</b>	Indicates an imminent hazardous situation which could lead to death or serious injury if ignored.
	<b>Warning</b>	Indicates an imminent hazardous situation which could lead to death or serious injury if ignored.
	<b>Caution</b>	Indicates a potentially hazardous situation which could lead to slight or minor injuries if ignored.
–	<b>Caution</b>	Indicates a situation which could result in material damage if ignored.

---

Tab. 1.2 Meaning of warning symbols and signal words

## 2 Safety

### 2.1 General safety instructions

**INFO** The appliance complies with the stipulated safety requirements. The user is responsible for appliance cleaning and maintenance as well as its safe use. Improper use can lead to personal injury and damage to property.

- The operating and installation instructions contain important information about installation and operation. These enable you to protect yourself against injuries and prevent damage to the appliance. Contact details for further information as well as application and usage questions can be found on the back of these operating and installation instructions.
- The term “appliance” is used to refer to cooktops, cooktop extractors or cooktops with integrated cooktop extractor.
  - ▶ Read the operating and installation instructions fully before using the appliance for the first time.
  - ▶ Always store the operating and installation instructions within easy reach so that they can be accessed if required.
  - ▶ Pass the operating and installation instructions to the next owner if you sell the appliance.
  - ▶ Conduct all work extremely attentively and conscientiously.
  - ▶ Check the appliance for visible damage when unpacking it.
  - ▶ Do not connect a damaged appliance.
  - ▶ Do not connect the appliance to the mains until the duct system has been installed or the recirculation filter has been fitted.
  - ▶ Do not use the appliance until installation is complete. This is the only way to ensure safe operation.
  - ▶ Make sure contact with hot cooking surfaces is not possible.
  - ▶ Do not place any objects on the operating panel or the cooktop extractor air inlet nozzle.
  - ▶ Switch off the appliance after use.
  - ▶ Keep pets away from the appliance.

#### CAUTION!

#### Appliance components can cause injury if dropped!

Appliance components such as pan supports, operating controls, covers, grease filters, etc. can cause injury if dropped.

- ▶ Place any appliance components that have been removed in a safe place near the appliances.
- ▶ Ensure that no components removed from the appliance can fall on the floor.

#### Unauthorised modifications

Unauthorised modifications can cause the appliance to pose risks.

- ▶ Do not make any changes to the appliance.

#### Households with children and people with special needs

- ▶ The appliance can be used by children aged 8 and above as well as people with reduced physical, sensory or mental capacities or a lack of experience and/or knowledge if they are supervised or have been instructed how to use the appliance safely and understand the resultant risks.
- ▶ Supervise children in the vicinity of the appliance.
- ▶ Children must not play with the appliance.
- ▶ Use the childproofing feature in order to prevent children from switching on the cooktop or changing the settings when they are unattended.
- ▶ Do not store any items that could be of interest to children in storage spaces above or behind the appliance. Otherwise, they will be tempted to climb onto the appliance.
- ▶ Keep children and other persons away from the cooking surfaces when hot.

#### Recirculation mode

**INFO** When cooking, additional moisture is released into the ambient air.

**INFO** In recirculation mode, only a slight amount of moisture is removed from the cooking vapour.

- ▶ When using recirculation mode, ensure a sufficient supply of fresh air, e.g. by opening a window.
- ▶ Ensure a normal and comfortable room climate (humidity of 45–60%), e.g. by opening natural ventilation openings or using domestic ventilation systems.
- ▶ After every use in recirculation mode, switch the cooktop extractor to a low level for about 20 minutes or activate the automatic after-run function.

## 2.2 Safety instructions – Cooktop operation

- ▶ Avoid over-cooking.
- ▶ Pay attention to the residual heat display.
- ▶ Do not place any hot cookware in the area of the cooktop display so as not to damage the underlying electronics.
- ▶ Make sure that the base of the cookware as well as the cooking zones are clean and dry.
- ▶ Always lift (do not drag!) the cookware to prevent scratching and abrasion on the surface.



### **DANGER!**

#### **Danger of fire caused by leaving the cooktop unattended!**

Oil or fat in the pot can quickly heat up and ignite.

- ▶ Never leave oil or fat to heat up unattended.
- ▶ Never extinguish oil and fat fires with water.
- ▶ Suffocate the fire, for example by using a lid.



### **DANGER!**

#### **Risk of explosion caused by flammable liquids!**

Flammable liquids in the vicinity of the cooktop can explode and cause serious injury.

- ▶ Do not spray aerosols in the vicinity of this appliance while it is in operation.
- ▶ Do not place any flammable liquids in the vicinity of the cooktop.



### **DANGER!**

#### **Risk of electric shock!**

Cracks, fissures or fractures in the glass ceramic panel can damage the underlying electronics. This can cause an electrical shock.

- ▶ If there are any cracks, fissures or fractures in the glass ceramic, switch the appliance off immediately.
- ▶ Securely disconnect the appliance from the mains using the LS switch, fuses, automatic circuit breakers or contactor.



### **WARNING!**

#### **Risk of burns from hot cooktop!**

The cooktop and its exposed areas get hot during use. Once the cooking zone is switched off, it takes a little while to cool down to below 60 °C. Touching hot surfaces can cause serious burns.

- ▶ Never touch the cooktop when it is hot.
- ▶ Keep children away from the cooktop when it is hot or ensure they are supervised at all times.



### **WARNING!**

#### **During or after a power cut, cooktops may still be hot!**

In the event of a power cut, a cooktop that was previously in operation may still be hot even though there is no indication of residual heat.

- ▶ Do not touch the cooktop while it is still hot.
- ▶ Keep children away from the hot cooktop.



### **WARNING!**

#### **Risk of fire from objects on the cooking surfaces!**

The cooktop and its exposed parts are hot when the cooking zone is switched on and during the cooling phase. Objects on the cooktop can heat up and catch fire.

- ▶ Do not place any items on the cooktop.

**WARNING!****Risk of burns from hot objects!**

The cooktop and its exposed parts are hot when the cooktop is in use and during the cooling phase. Objects on the cooktop heat up very quickly and can cause serious burns. This particularly applies to metal objects (e.g. knives, forks, spoons, lids or cooktop extractor covers).

- ▶ Do not place any items on the cooktop.
- ▶ Please use suitable tools (pot holders, oven gloves).

**WARNING!****Risk of burns from hot cookware!**

Handles projecting over the edge are enticing for children to grab.

- ▶ Do not turn pot and pan handles so they stick out beyond the work surface.
- ▶ Make sure that children cannot pull hot pots and pans over.
- ▶ Use suitable stove guards.
- ▶ Do not use unsuitable stove guards (accident risk).
- ▶ To choose a suitable stove guard, contact your specialist supplier or the BORA Service Team.

**WARNING!****Risk of burns!**

Liquid between the cooking zone and the pan base can evaporate and cause burns.

- ▶ Make sure that the cooking zone and the pan base are always dry.

**CAUTION!****Damage from hard and pointed objects!**

Hard and pointed objects can damage the glass ceramic panel of the cooktop.

- ▶ Do not use the surface of the cooktop as a worktop.
- ▶ Do not use hard and pointed objects when working on the cooktop.

**CAUTION!****Damage from sugary and salty foods!**

Sugary and salty foods and juices can damage the hot cooking zone.

- ▶ Make sure sugary and salty foods or juices do not get onto the cooking zone while it is hot.
- ▶ Remove sugary and salty foods and juices from the hot cooking zone immediately.

**CAUTION!****Escaping hot liquids!**

Unattended pans can boil over allowing hot liquids to escape.

- ▶ Always keep an eye on pans while cooking.
- ▶ Short cooking sessions must be constantly monitored.

**CAUTION!****Damage caused by objects on the cooktop!**

Objects such as cookware lids on the cooktop can damage the glass ceramic panel.

- ▶ Do not place any objects on the cooktop while it is hot.

### 2.2.1 Safety instructions – cooktop installation

- ▶ Do not rely on the pan size recognition.

### Effect on pace makers, hearing aids and metal implants

**INFO**

Induction cooktops generate a high-frequency electromagnetic field in the area of the cooking zones. The cooking zones may affect pacemakers, hearing aids or metal implants negatively or disturb their function when in close proximity. A reduced function of the pacemaker is unlikely.

- ▶ If in doubt, contact the manufacturer of your medical device or your doctor.

### 2.3 Safety instructions – Cooktop extractor

- ▶ Do not place any hot cookware on the air inlet nozzle of the cooktop extractor.
- ▶ Make sure that hot cookware does not touch the edge of the air inlet nozzle.



**DANGER!****Risk of smoke inhalation!**

Using a fireplace that depends on the air in the room produces combustion gases.

If the cooktop extractor is used in conjunction with a fireplace that depends on the air in the room, toxic combustion gases (carbon monoxide) can be extracted from the chimney or outlet duct into the living area.

- ▶ Make sure that there is always a sufficient air supply.

**DANGER!****Fire risk from flambéing!**

While the cooktop extractor is working, it sucks up grease from cooking.

Flambéing food can cause the grease to catch fire.

- ▶ Clean the cooktop extractor regularly.
- ▶ Never work with a naked flame while the cooktop extractor is running.

**DANGER!****Fire risk from fat deposits!**

If the stainless steel grease filter is not cleaned regularly, this can lead to increased levels of grease in it. This increases the fire risk.

- ▶ Clean and replace the filter at regular intervals.

**CAUTION!****Exposed parts may become hot!**

The cooktop extractor and its exposed parts are hot when the cooking zone is switched on and during the cooling phase.

- ▶ Please use suitable tools (pot holders, oven gloves).

**WARNING!****Risk of injury when opening the bottom housing cover!**

There is a risk of injury while the fan is turning.

- ▶ Switch off the cooktop extractor and the cooktop.
- ▶ Turn off the mains supply.

**CAUTION!****Damage caused by objects or paper suctioned in!**

Small and light items, such as cleaning cloths made from material or paper, can be suctioned into the cooktop extractor. This can damage the fan or impair the exhaust performance.

- ▶ Do not store any items or paper on the cooktop extractor.

**CAUTION!****Damage caused by grease and dirt deposits!**

Grease and dirt deposits can prevent the cooktop extractor from functioning properly.

- ▶ Never use the cooktop extractor without a stainless steel grease filter.

## 2.4 Safety Instructions – Installation

The appliance must only be installed and assembled by trained specialists who are familiar with and comply with the standard national regulations and supplementary regulations of the local utility companies.

Work on electrical components must be conducted by trained electrical personnel.

The electrical safety of the appliance is only guaranteed if it is connected to a protective conductor system that has been installed in line with regulations. Ensure that this basic safety precaution is met.

- ▶ Check the appliance for visible damage prior to installation.
- ▶ Do not install any damaged appliance.
- A damaged appliance may put your safety at risk.

Repair and maintenance work may only be carried out by specialists authorised by the manufacturer.

**DANGER!****Risk of asphyxiation!**

Packaging components (e.g. film, polystyrene) can be life-threatening for children.

- ▶ Store all packaging components out of reach of children.
- ▶ Dispose of the packaging properly and immediately.

### 2.4.1 Safety Instructions – Cooktop installation

**DANGER!****Risk of electric shock!**

Connecting the appliance to the mains incorrectly poses a risk of electric shock.

- ▶ Make sure that the appliance has a fixed connection to the mains voltage.
- ▶ Make sure that the appliance is connected to a properly installed protective conductor system.
- ▶ Make sure that technical equipment is provided to enable all of the appliance's poles to be disconnected from the mains with a contact opening width of at least 3 mm (LS switch and automatic circuit breakers, fuses, contactor).

**DANGER!****Risk of electric shock!**

The connection cable can be damaged if it comes into contact with hot cooking zones. A damaged connection cable can cause a (fatal) electrical shock.

- ▶ Make sure that the connection cable does not come into contact with hot cooking surfaces.
- ▶ Make sure that the connection cable does not become trapped or damaged.

**CAUTION!****Lifting heavy loads can cause back injuries!**

If not handled correctly, removing and installing the appliance can cause injuries to the limbs or torso.

- ▶ Removing the cooktop from the packaging is a two-person job.
- ▶ Placing the cooktop into the worktop cut-out is a two-person job.
- ▶ Use appropriate aids to prevent damage or injuries to limbs or torso.

### 2.4.2 Safety Instructions – Cooktop extractor

**DANGER!****Risk of poisoning caused by combustion gases!**

When the cooktop extractor is used in exhaust mode, it draws in air from the room it is installed in and from neighbouring rooms. Without sufficient air, there will be a drop in air pressure. Toxic gases could be drawn out of the chimney or extraction ducting on a fireplace that depends on the room air and back into the room.

- ▶ Make sure that there is always a sufficient air supply.
- ▶ Only use reliable, tried-and-tested switching devices, (e.g. window contact switch, low pressure warning device) and have them approved by a qualified expert (certified chimney sweep).

**DANGER!****Risk of electric shock!**

Incorrect stripping of the connection cable to external switching devices results in a risk of electric shock.

- ▶ Ensure that the stated stripping lengths are adhered to.

### Special safety information for exhaust systems

- ▶ Please pay attention to the channel length between the fan and the wall sleeve in straight channel design.
- A minimum space of 90 cm between the blow out opening of the fan and the blow out opening of the wall sleeve must be planned in.

### 2.5 Safety instructions – Cleaning and Maintenance

The appliance must be cleaned at regular intervals. Dirt can lead to damage or bothersome odours. Remove dirt immediately.

- Any work involving cleaning and maintenance must not be carried out by children unless they are supervised at all times while doing so.
- ▶ Do not use a steam cleaner for cleaning. Steam can cause a short circuit on live parts and thus lead to property damage (see the Cleaning and Maintenance chapter).

- ▶ When cleaning, ensure that no water penetrates the appliance. Use only a slightly damp cloth. Never spray the device with water. Water penetration can cause damage!
- ▶ Whenever possible, clean the cooktop after every use.
- ▶ Clean the cooktop only after it has cooled down.
- ▶ When cleaning, only use non-abrasive detergents to prevent scratching and abrasion on the surface.

## 2.6 Safety instructions – disassembly and disposal

The appliance must only be disassembled by trained specialists who are familiar with and comply with the standard national regulations and supplementary regulations of the local utility companies.

Work on electrical components must only be conducted by trained electrical personnel.



### **DANGER!**

#### **Risk of electric shock!**

Incorrectly disconnecting the appliance from the mains results in a risk of electric shock.

- ▶ Securely disconnect the appliance from the mains using LS switches, fuses, automatic circuit breakers or contactors.
- ▶ Use an authorised measuring device to ensure that there is no power to the appliance.
- ▶ Do not touch exposed contacts on the electronic unit as they can contain residual charge.

## 2.7 Safety instructions – spare parts



### **WARNING!**

#### **Risk of injury and damage to property!**

Incorrect components can lead to personal injury or damage to the appliance. Modifications, additions or alterations to the appliance can lead to safety risks.

- ▶ Only use original spare parts for repairs.

### **INFO**

A damaged power supply cable must be replaced by a suitable power supply cable. This may only be done by an authorised member of the After Sales Service team.

## 2.8 Use as intended

The appliance cannot be used at altitudes above 2,000 m (metres above sea level).

The appliance is solely intended for preparing food in private households. This appliance is not intended for:

- Outdoor use
- Installation in vehicles
- Heating rooms
- Use in non-stationary installation sites (e.g. on ships)
- Use with an external timer or a separate remote control system (remote operation)

Any use other than that specified in these operating and installation instructions or any use that goes beyond that which is described here is classed as unintended. BORA does not assume any liability for damages caused by improper use or incorrect operation.

### **All misuse is prohibited!**

### **INFO**

BORA Holding GmbH, BORA Vertriebs GmbH & Co KG, BORA APAC Pty Ltd and BORA Lüftungstechnik GmbH do not assume any liability for damage arising from non-adherence to the safety and warning information.

### 3 Technical data

Parameter	Value
Supply voltage	380-415 V
Frequency	50/60 Hz
Power consumption	7.6 kW
Fuse protection, minimum	1 x 32 A / 2 x 16 A
Total power	7.6 kW
Line-to-line voltage	AC 220-240 V / 50 Hz
Main dimensions	830 x 515 x 198 mm
Weight (incl. accessories/packageing)	Approx. 25 kg
<b>Cooktop</b>	
Front cooking zones	230 x 230 mm 2100 W
power setting	3700 W
Rear cooking zones	230 x 230 mm 2100 W
power setting	3700 W
Power levels	1-9, power setting
<b>Cooktop energy consumption (pan size)</b>	
Cooking zone 1 front left (150 mm)	194,1 (Wh/kg)
Cooking zone 2 back left (180 mm)	177 (Wh/kg)
Cooking zone 3 front right (150 mm)	194 (Wh/kg)
Cooking zone 4 back right (180 mm)	177,1 (Wh/kg)
Cooking zones 3 and 4 bridget (210 mm)	202,5 (Wh/kg)
Total (average)	193,1 (Wh/kg)
<b>Extraction system (BFIA)</b>	
Maximum flow volume	697.3 m <sup>3</sup> /h
Maximum static pressure	372 Pa
Power control	1-9, power setting
Exhaust air connection (BFIA)	222 x 40 x 89 mm
<b>Recirculation system (BFIU)</b>	
Maximum flow volume	658.8 m <sup>3</sup> /h
Maximum static pressure	375 Pa
Power control	1-9, power setting
Recirculation connection (BFIU)	650 x 90 mm
<b>Recirculation filter</b>	
Filter area	2 x 0,4 m <sup>2</sup>
Filter capacity	150 operating hours
Service life	1 year

Tab. 3.1 Technical data

#### Device dimensions BFIA

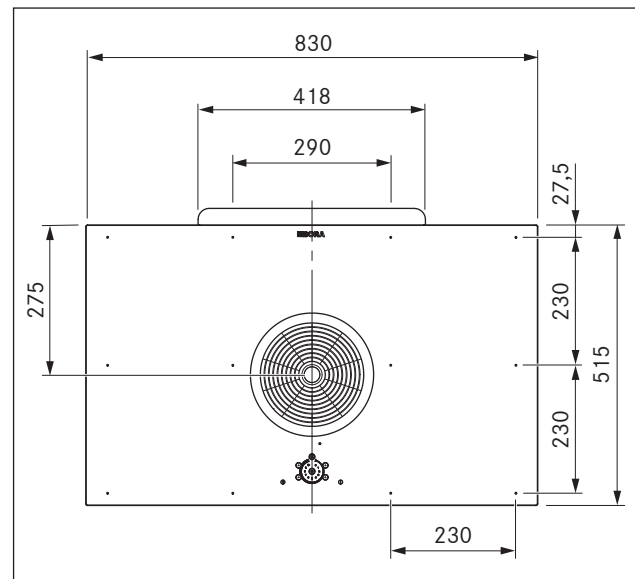

Fig. 3.1 BFIA Device dimensions aerial view

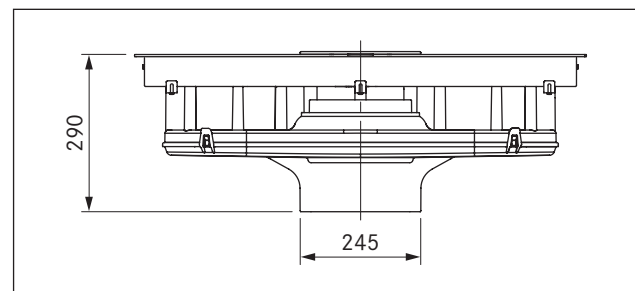

Fig. 3.2 BFIA Device dimensions front view

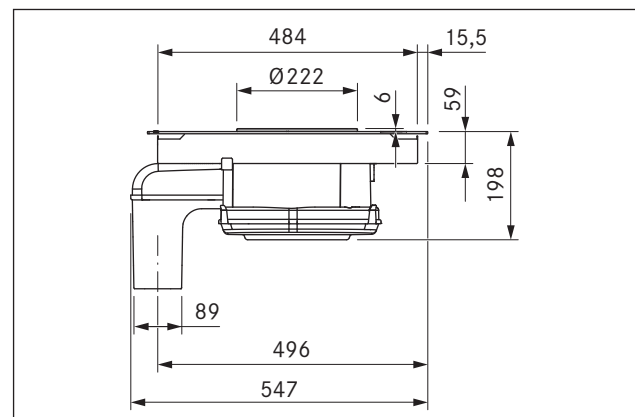

Fig. 3.3 BFIA Device dimensions side view

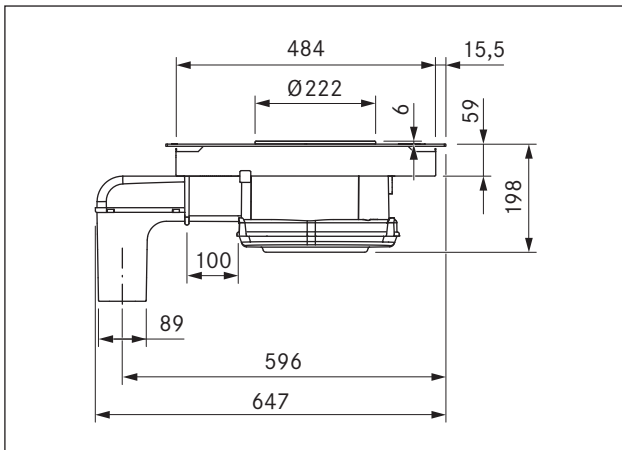

Fig. 3.4 Device dimensions with cable extension (BFIA + BLAVH1)

### Device dimensions BFIU

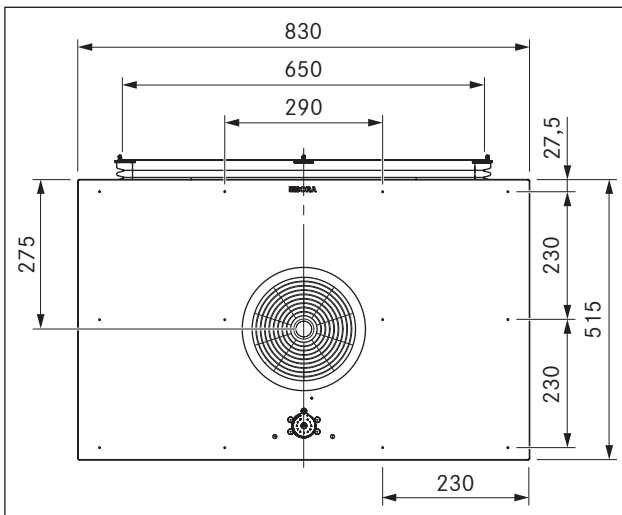

Fig. 3.5 BFIU Device dimensions aerial view

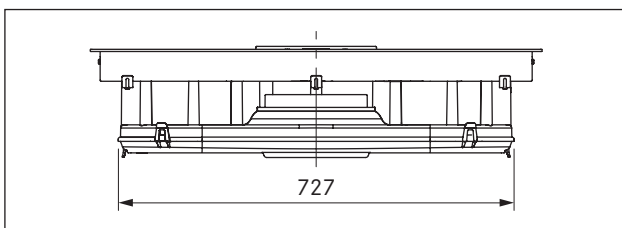

Fig. 3.6 BFIU Device dimensions front view

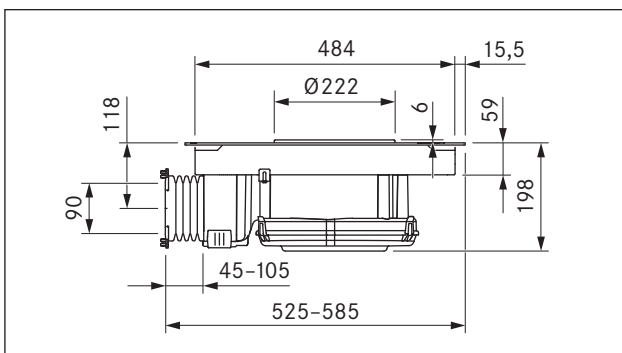

Fig. 3.7 BFIU Device dimensions side view

## 4 Energy label

Product description			
Glass ceramic cooktop with 4 cooking zones and an integrated cooktop extractor	BFIA	BFIU	
Operating mode	Exhaust air	Recirculation	
Energy consumption	Value	Value	EN standard
Annual energy consumption ( $AEC_{hood}$ )	54,8 kW/a	51,9 kW/a	61591
Energy efficiency class	B	*	61591
Flow volume			
Fluid dynamic efficiency ( $FDE_{hood}$ )	23.1	21.0	61591
Fluid dynamic efficiency class	B	*	61591
Lighting			
Lighting efficiency ( $LE_{hood}$ )	* lx/Watt	* lx/Watt	*
Lighting efficiency class	*	*	*
Grease filtering			
Level 9 maximum ( $GFE_{hood}$ )	91 %	91 %	61591
Class level 9 normal	B	*	61591
Grease filtering (additional details)			
Level P maximum ( $GFE_{hood}$ )	93 %	93 %	61591
Class level P maximum	B	*	61591
Flow volume			
Air flow level 1 minimum	194.8 m <sup>3</sup> /h	* m <sup>3</sup> /h	61591
Air flow level 9 normal	607.3 m <sup>3</sup> /h	* m <sup>3</sup> /h	61591
Air flow level P maximum ( $Q_{max}$ )	697.3 m <sup>3</sup> /h	658.8 m <sup>3</sup> /h	61591
Sound power level			
Level 1 minimum	40 dB(A)	39 dB(A)	60704-2-13
Level 9 normal	66 dB(A)	67 dB(A)	60704-2-13
Level P maximum	70 dB(A)	70 dB(A)	60704-2-13
Sound pressure level (additional details)			
Level 1 minimum	27 dB(A)	26 dB(A)	**
Level 9 normal	54 dB(A)	54 dB(A)	**
Level P maximum	57 dB(A)	57 dB(A)	**
Details according to 66/2014			
Power consumption in off mode ( $P_o$ )	< 0.5 W	< 0.5 W	61591
Time increase factor	1.2	1.2	61591
Energy efficiency index ( $EEl_{hood}$ )	65.2	64.5	61591
Air flow rate at the best efficiency point ( $Q_{BEP}$ )	382 m <sup>3</sup> /h	311.4 m <sup>3</sup> /h	61591
Pressure at the best efficiency point ( $P_{BEP}$ )	272 Pa	288 Pa	61591
Electric power input at the best efficiency point ( $W_{BEP}$ )	125 W	118.5 W	61591

Tab. 4.1 Energy label information

(The recirculation information is optional and not subject to mandatory inclusion on the label)

\* This specification is not applicable for this product.

\*\* The sound pressure level has been determined from a distance of 1 m (distance-dependent level recording) on the basis of the sound power level established in EN 60704-2-13.

## 5 Device description

Observe all safety and warning information during operation (see the Safety chapter).

The cooktop with cooktop extractor has the following features:

### Cooktop:

- Automatic heat up function
- Safety shut-down
- Bridging function
- Electronic power control (9 power levels)
- Childproofing feature
- Pause function
- power setting
- Residual heat display
- Timer functions
- Pan size recognition
- Heat retention levels

### Cooktop extractor:

- Freely adjustable power control
- Automatic cooktop extractor function
- Automatic after-run
- Safety shut-down
- Filter service display
- Interface communication

Depending on what you opted for when purchasing, the cooktop extractor can be operated as an exhaust air or an recirculating air version.



### Exhaust mode

The air extracted from the cooktop is cleaned by the stainless steel grease filter and released outside through a duct system.

The exhaust air must not be expelled into:

- a smoke or exhaust gas flue that is in operation;
- a shaft used for the aeration of rooms where fireplaces are installed.

If the exhaust air is to be directed into a smoke or exhaust gas flue that is not in use, the installation must be checked and approved by the responsible heating engineer.



### Recirculation mode

The air suctioned away by the cooktop is purified by the stainless steel grease filter and an activated charcoal filter and fed back into the room in which the appliance is installed. To prevent odours in the recirculated air, an activated charcoal filter must be used.

For hygiene and health reasons, the activated charcoal filter must be replaced at the recommended intervals (see the Cleaning and maintenance section).

**INFO** In recirculation mode, ensure sufficient ventilation and aeration to expel humidity.

The activated charcoal filter is equipped with an integrated fine filter. The filter in the activated charcoal filter is made from special activated charcoal, which is ideal for trapping cooking odours.

### 5.1 Structure

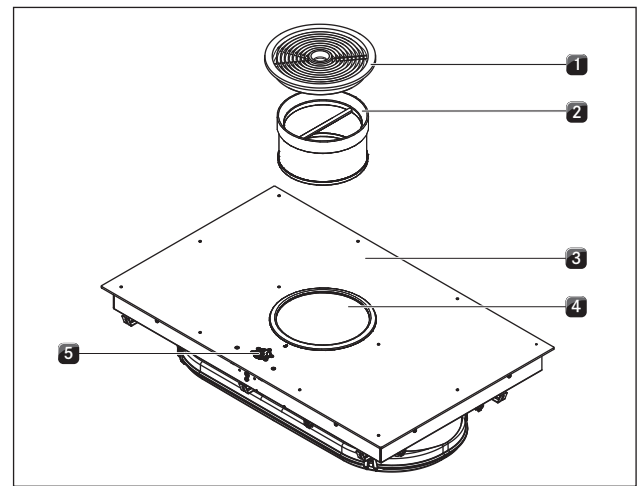

Fig. 5.1 Cooktop

- [1] Air inlet nozzle
- [2] Stainless steel grease filter
- [3] Cooktop
- [4] Suction opening
- [5] Operating panel

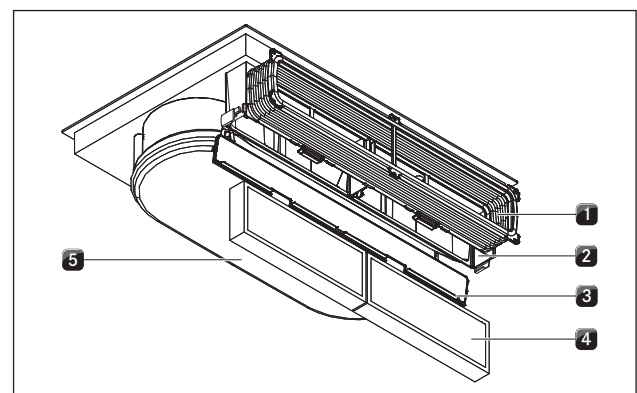

Fig. 5.2 Cooktop extractor – recirculation (BFIU)

- [1] Flexible duct
- [2] Activated charcoal filter housing
- [3] Activated charcoal filter housing cover
- [4] Activated charcoal filter
- [5] Air guiding housing with housing base

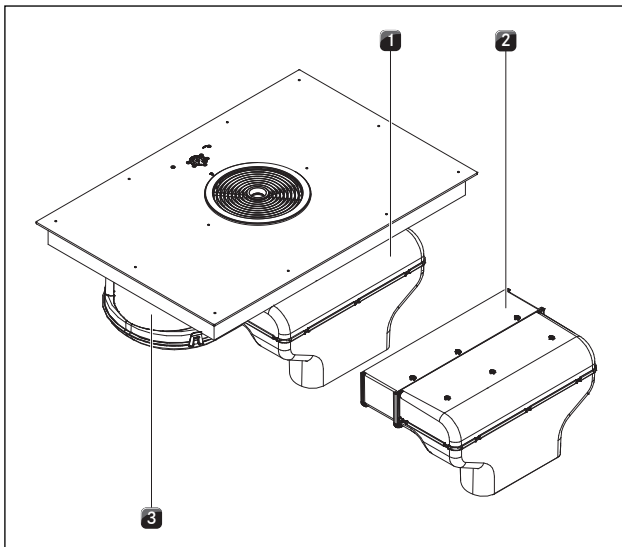

Fig. 5.3 Cooktop extractor – exhaust air (BFIA)

- [1] Exhaust air arc with duct connection
- [2] Horizontal exhaust air extension
- [3] Air guiding housing with housing base

## 5.2 Operating panel and operating principle

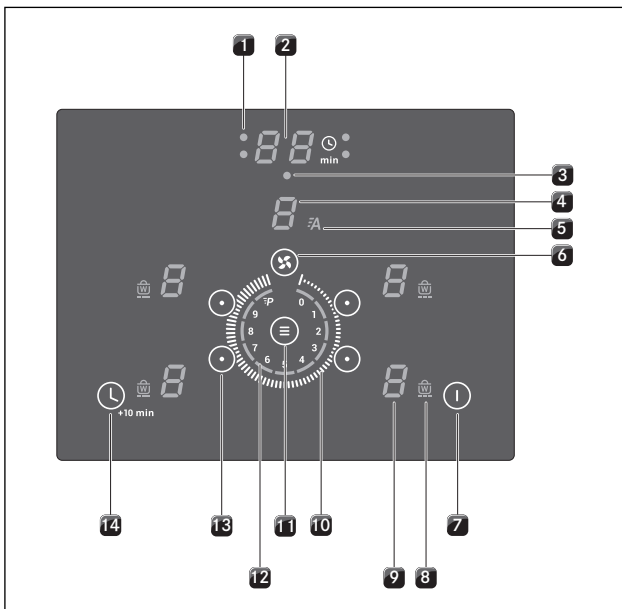

Fig. 5.4 Operating panel

### Sensor buttons:

- [7] Switching the cooktop/cooktop extractor on/off
- [11] Multi-function button
- [14] Activating the timer
- [14] Setting the timer value (+10 min)

### Setting ring:

- [6] Selecting the cooktop extractor
- [10] Adjusting the power level
- [10] Setting the timer value (minutes)
- [10] Locking/unlocking the childproofing feature
- [10] Locking/unlocking the pause function
- [13] Selecting the cooking zone

### Display fields:

- [1] Automatic cut-off timer control light
- [2] Timer display
- [3] Short-time timer control light
- [4] Fan display/filter service display
- [5] Automatic cooktop extractor display
- [8] Heat retention level display
- [9] Cooking zone indicator
- [12] Power display

Display field	Display	Meaning
Fan display	0	Fan off
	1 - 9	Power level
	P	Power setting
	n	Automatic after-run
	F	Filter service display
Automatic cooktop extractor function	A	Active
Cooking zone indicator	1 - 9	Power level
	P	Power setting
	R	Automatic heat up function
	L	Childproofing feature
	n	Bridging function
		Break
	-	Heat retention level 42°C
	=	Heat retention level 74°C
	≡	Heat retention level 94°C
	⊥	No cookware or cookware is too small.
H	Residual heat display: Cooking zone is switched off but still hot (temperature > 60°C)	
Heat retention level display	On	Active
Timer control light	On	Active
	Flashes	Timer on (00); no time set
	Off	Timer off
Timer display	01 - 99	Set minutes for short time (egg timer) or automatic cut-off
	00	Timer on; no time set

Tab. 5.1 Meaning of displays



## Touch control

The operating panel is fitted with electronic sensor buttons, a setting field and display panels. The sensor buttons respond to finger contact.

You operate the device by touching the corresponding sensor button with your finger. Keep the finger pressed on the sensor button until you either hear an acoustic signal or the display changes accordingly.

## 5.3 Functional principle of the cooking zone

An induction coil is located underneath an induction cooking zone. If the cooking zone is switched on, this coil creates a magnetic field that acts directly on the base of the pot thus heating it up. The cooking zone is only indirectly heated up by the heat emitted by the pot. Cooking zones with induction only work if the cookware has a magnetisable base.

The induction automatically takes into account the size of the cookware used so that only the area in the cooking zone covered by the base of the pot is heated up.

► Observe the minimum pot base diameter.

The cooking zone does not work

- if it is switched on without cookware or with unsuitable cookware;
- if the base diameter of the cookware is too small;
- if the cookware is removed from a switched on cooking zone.

A  $\sqcup$  will appear in the cooking zone indicator if cookware that is unsuitable or too small is used.

### 5.3.1 Power levels

The high power output of induction cooktops results in the very quick heating up of cookware. A slight adjustment is needed in comparison to conventional cooking systems when selecting the power level in order to avoid burning food.

Activity	Power level
Melting of butter and chocolate, breaking up gelatine	1
Keeping sauces and soups warm, soaking rice	1-3
Cooking potatoes, pasta, soups, ragouts, steaming fruit, vegetables and fish, defrosting food	2-6
Frying in coated pans, moderate frying (without overheating the fat) of pork cutlets, fish	6-7
Heating up fat, browning fish, cooking thickened sources and soups, making omelettes	7-8
Cooking large quantities of liquid, browning steaks	9
Heating up water	P

Tab. 5.2 Recommendations for power levels

The specifications provided in the table are standard values.

Depending on the cookware and filling quantity, it is recommended to either decrease or increase the power level.

### 5.3.2 Automatic heat up function

The cooking zones are equipped with an automatic heat up function that can be switched on and off.

■ The display shows  $\bar{P}$ .

This function enables the cooking zone to work at full power for a certain duration after switching on. After this time, the power level is automatically switched back to the power level set.

Automatic heat up function								
Power level	1	2	3	4	5	6	7	8
Cooking duration in min./sec	0:48	2:24	3:50	5:12	6:48	2:00	2:48	3:36

Tab. 5.3 Overview of the automatic heat up function

### 5.3.3 power setting

All cooking zones are equipped with a power-enhancing power setting.

The power setting can be used in order to quickly heat up large quantities of water. If the power setting is activated, the cooking zones will run at extra high power. After 10 minutes, the cooking zone is automatically switched to power level  $\bar{9}$ .

If one cooking zone is operated with the  $\bar{P}$  power setting, then the operation of the second cooking zone on this side is possible at a maximum of power level  $\bar{5}$ .

If the bridging function is activated, the power setting cannot be used.

If cooking zone overheating protection is activated, the power setting cannot be activated. The display flashes for 3 seconds and then switches back.

**INFO** Never heat up oil, fat and the like at this power setting. The bottom of the pan can overheat due to the high power output.

### 5.3.4 Heat retention levels

The heat retention level keeps cooked foods warm at different temperatures.

■ The heat retention level display is active and lit.

■ The heat retention level is shown in the cooking zone indicator e.g. for level 2  $\bar{2}$ .

■ The maximum duration for the warming function is limited to 8 hours.

Heat retention level	Temperature in °C
Level 1	42 °C
Level 2	74 °C
Level 3	94 °C

Tab. 5.4 Heat retention levels

### 5.3.5 Bridging function

The two side cooking zones can be operated as a connected cooking zone at the same power level.

■ The display shows .

The bridging function is suitable for heating food in a roaster.

### 5.3.6 Pause function

The cooking session can be temporarily interrupted.

■  appears in the display.

■ The cooking session and set timer are interrupted while the pause function is active.

■ The pause function is limited to a maximum duration of 10 minutes.

### 5.3.7 Timer functions

You can use 2 timer functions:

■ Short-time timer (egg timer), no automatic switching off of a cooking zone.

■ Automatic cut-off for automatically switching off a cooking zone.

### 5.3.8 Pan size recognition

The cooking zone does not work

■ if  is shown in the display;

■ if it is switched on without cookware or with unsuitable cookware;

■ if the base diameter of the cookware is too small;

■ if the cookware is removed from a switched on cooking zone.

■ After 10 minutes have passed without a pan being detected, the cooking zone will switch off automatically.

### 5.3.9 Suitable cookware

**INFO** The heating and heat through time for the base of the cookware as well as the cooking results are significantly influenced by the structure and material of the cookware.



Cookware with this symbol is suitable for induction cooktops.

The cookware used for the induction cooktop must be made of metal, feature magnetic properties and possess a sufficient bottom surface.

Suitable cookware is made of:

■ stainless steel with a magnetisable base

■ enamelled steel

■ cast iron

Cooking zone	Minimum diameter
Front	120 mm
Back	120 mm

Tab. 5.5 Minimum cookware diameter

▶ Perform a magnet test, if necessary. If a magnet sticks to the base of the utensils, they are normally induction compatible.

▶ Pay attention to the cookware bottom. The base of the cookware should not show any sign of curvature. Due to incorrect temperature monitoring of the hob caused by the air gap between the cookware and the temperature sensor underneath the hob, overheating may occur. The bottom of the cookware must not have any sharp grooves or sharp edges to avoid scratching the cooktop.

▶ Place the cookware (without a mat or similar) directly onto the glass ceramic.

### Noises

The following noises may occur in the cookware when using induction cooking zones, depending on the material and the finish of the base:

■ **Humming** may occur when using a high power level. It decreases or disappears if the power level is decreased.

■ **Crackling or whistling** may occur due to the bases of cookware made of different materials (e.g. sandwich base).

■ **Clicking sounds** may occur during electronic switching procedures especially at low power levels.

■ **Whirring** may occur when the cooling fan is switched on. In order to increase the service life of the electronic system, the cooktop is equipped with a cooling fan. The cooling fan switches on automatically if the cooktop is used intensively. You will hear a whirring sound. The cooling fan may continue running after the device has been switched off.

## 5.4 Functional principle of the cooktop extractor

### 5.4.1 Freely adjustable power control

The power levels are controlled using the central setting field on the operating panel.

### 5.4.2 Automatic cooktop extractor function

The automatic cooktop extractor function adjusts the extraction performance (power level) to the highest cooking zone cooking level used.

Function	Power levels									
Extractor level	4	4	4	4	5	6	7	8	9	P
Cooking level	1	2	3	4	5	6	7	8	9	P

Tab. 5.6 Extraction performance and cooking level

■ If the power level of the cooking zones is changed, the automatic cooktop extractor function adjusts the cooktop extractor performance after a 30 second delay.

■ Once the cooking session is complete, the automatic after-run is activated.

### 5.4.3 Power setting

The cooktop extractor has a power-enhancing power setting.

This power setting makes it possible to suction away high levels of cooking vapours more quickly. After 10 minutes, the power setting is automatically switched to power level 9.

### 5.4.4 Automatic after-run

The cooktop extractor continues to run at a lower level  $n$  and switches off automatically after 20 minutes.

### 5.4.5 Filter service display

The filter service display becomes active after the cooktop extractor has operated for 150 hours. The activated charcoal filters have reached the end of their service life (with recirculation only) and the stainless steel grease filter needs to be thoroughly cleaned.

- A flashing  $F$  is displayed in the filter service display.
- The filter service display is shown every time the cooktop extractor is switched on and remains active until the filter has been changed and the filter service display is reset.
- The cooktop extractor can still be operated without limitations.

### 5.4.6 Interface communication

The internal interface can be used for extended control options. This has a Home-In and a Home-Out contact (see Installation chapter).

- The Home-In contact can be used for the incoming signal from external switch devices (e.g. window contact switch).
- The Home-Out contact can be used to control external installations.

## 5.5 Safety devices

### 5.5.1 Residual heat display

**INFO** While  $H$  is displayed in the cooking zone indicator (residual heat display), do not touch the cooking zone or place any heat-sensitive objects on top of it. Risk of burns and fire!

After switching it off, the cooking zone remains hot.  $H$  is displayed in the cooking zone indicator (residual heat display). The cooking zone indicator will go out after sufficient cooling time (temperature  $< 60^{\circ}\text{C}$ ).

### 5.5.2 Safety shut-down

#### Cooking zone

Each cooking zone is switched off automatically when the cooking zone exceeds the maximum operating duration at a power level.  $H$  (residual heat display) is then displayed in the cooking zone indicator.

Heat retention level	Power level	Switch off after hours
1		2.0
2		2.0
3		2.0
	1	6.0
	2	6.0
	3	5.0
	4	5.0
	5	4.0
	6	1.5
	7	1.5
	8	1.5
	9	1.5
	P	0.2

Tab. 5.7 Overview of the safety shut-down

- ▶ Switch the cooking zone back on (see Operating control) if you want to put the cooking zone back into operation.

### Cooktop extractor

The cooktop extractor switches off automatically if no buttons are pressed for 120 minutes.

### 5.5.3 Overheating protection

**INFO** If the cooktop overheats, the power is reduced or the cooktop is switched off completely.

The device is fitted with overheating protection. The overheating protection can be triggered if:

- Cookware is heated up empty.
  - Oil or fat is heated on high power.
  - A hot cooking zone is switched on again after a power cut.
- Whilst the overheating protection is active, one of the following steps is taken:
- The activated power setting is switched back to the previous level.
  - The power setting P can no longer be switched on.
  - The set power level is reduced.
  - The cooktop switches off completely.

After a sufficient cooling period, the cooktop can be used again in full.

### 5.5.4 Automatic switch-off if the button is pressed and held

The cooktop will be switched off automatically when one or more sensor buttons are touched for longer than 10 seconds (finger contact, objects, soiling).

- After a few seconds, the cooktop will switch off.
- ▶ Remove the finger or object from the cooktop.
- ▶ Clean the cooktop as required.
- ▶ Where necessary, switch the cooktop back on.

### 5.5.5 Childproofing feature

The childproofing feature prevents the cooktop from being switched on accidentally. The childproofing feature can only be activated when the cooktop is switched on and all cooking zones are switched off (see the Operation chapter).

## 6 Installation

- ▶ Observe all safety and warning information (see the Safety chapter).
- ▶ Follow the enclosed manufacturer's information.

**INFO** The power supply cable must be provided by the customer.

**INFO** The device must not be installed above cooling devices, dishwashers, stoves, ovens, washing machines or dryers.

**INFO** The contact surfaces of the worktops and wall sealing strips must be made of a heat-resistant material (up to approx. 100°C).

**INFO** Worktop cut-outs must be moisture-sealed using suitable means and, where necessary, fitted with a thermal insulator.

### 6.1 Checking the scope of delivery

Name	Quantity
Surface induction glass ceramic cooktop with cooktop extractor	1
Air inlet nozzle	1
Stainless steel grease filter	1
BAKF activated charcoal filter (BFIU only)	2
Flexible duct (BFIU only)	1
EURO screws (BFIU only)	6
BLAVH1 horizontal exhaust air extension (BFIA only)	1
Mounting straps	5
Sealing tape	1
Glass ceramic scraper	1
Cable routing clips	3
Protective hose	2
Cable tie	2
Operating and installation instructions	1
Lenshead screw	5
Drilling template (BFIU only)	1
Height adjustment plate set	2

Tab. 6.1 Scope of delivery

- ▶ Check the scope of delivery for damage and make sure it is complete.
- ▶ If there are any missing or damaged parts, please notify BORA After Sales Service immediately.
- ▶ Do not under any circumstances install parts which are damaged.
- ▶ Dispose of transport packaging in the proper manner (see the Decommissioning, Disassembly and Disposal chapter).

### 6.2 Tool and aids

The following tools are required for the correct installation of the cooktop:

- Pencil
- Standard or cordless drill with a 5 mm wood drill (for the rear wall)
- Compass saw or hand saw
- Drilling template for cut-out on rear wall (included in scope of delivery)
- Phillips screwdriver Z2
- Silicone sealant for sealing cutting surfaces

### 6.3 Assembly instructions

#### 6.3.1 Safety distances

- ▶ Maintain the following safety distances:

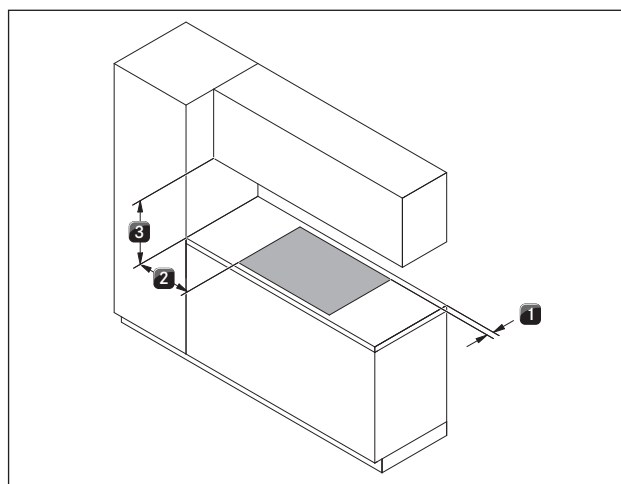

Fig. 6.1 Recommended minimum clearances

- [1] Rear minimum clearance of 50 mm between the worktop cut-out and the rear corner of the worktop.
- [2] Minimum clearance of 300 mm from the left and right of the worktop cut-out to the adjacent cabinet or wall.
- [3] Minimum clearance of 600 mm between the worktop and the wall unit. A minimum clearance of 1000 mm is recommended for ergonomic reasons.

#### 6.3.2 Worktop and kitchen units

- ▶ Create the worktop cut-out taking into account the specified cut-out dimensions.
- ▶ Make sure that the cut surfaces of the worktops are properly sealed.
- ▶ Comply with the instructions of the worktop manufacturer.
- Cross bars on the kitchen unit in the area of the worktop cut-out may need to be removed.
- No false floor is necessary below the cooktop. If cable protection (false floor) is planned, the following must be taken into account:
  - It must be fitted in such a way that it can be removed for maintenance work.

- To ensure sufficient cooktop ventilation, a minimum distance of 15 mm to the bottom edge of the cooktop is to be observed.
- The drawers and/or shelves in the floor unit must be removable.
- A return flow aperture > 500 cm<sup>2</sup> is required in the kitchen units for recirculation appliances (e.g. by shortening the plinth boards or using suitable slatted plinths).

## 6.4 Cut-out dimensions for the cooktop

**INFO** All dimensions are shown from the front edge of the front cover.

### Worktop overhang

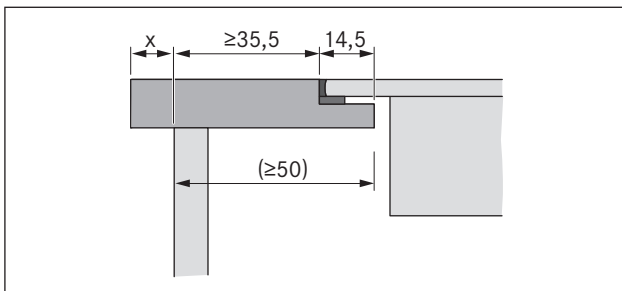

Fig. 6.2 Worktop overhang

- Please note the worktop overhang x when creating the worktop cut-out. Applies to flush installation and surface mounting.

### Flush installation

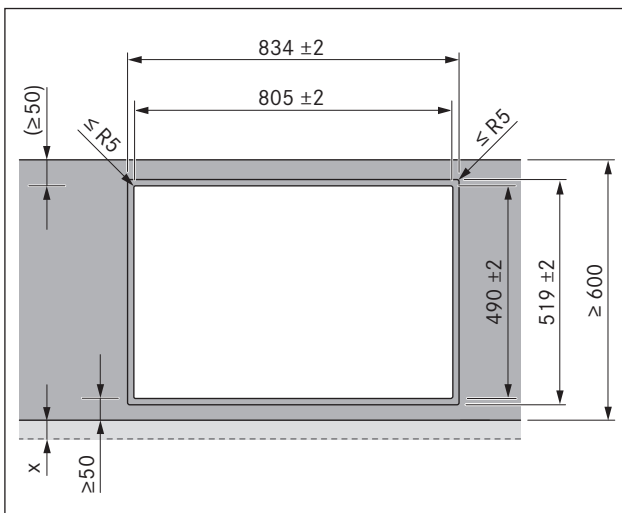

Fig. 6.3 Cut-out dimensions for flush installation

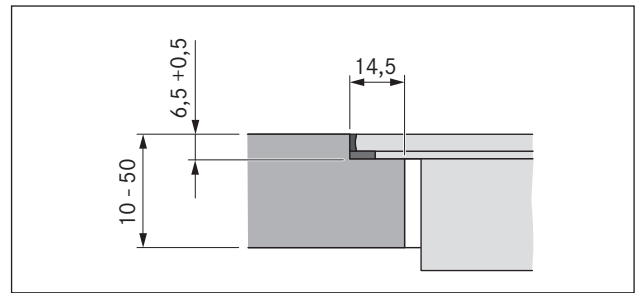

Fig. 6.4 Dimension of groove for flush installation

### Surface mounting

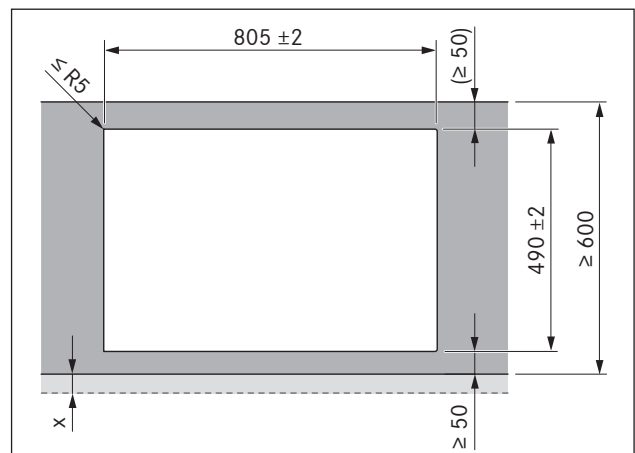

Fig. 6.5 Cut-out dimensions for surface mounting

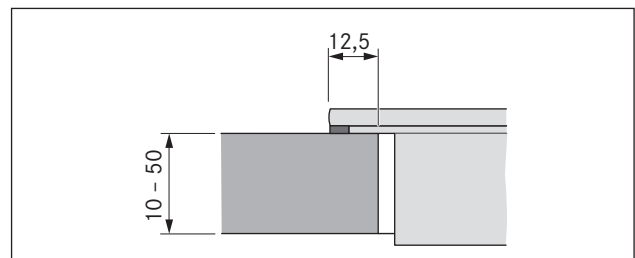

Fig. 6.6 Dimension of support for surface mounting

## 6.5 Attaching the sealing tape

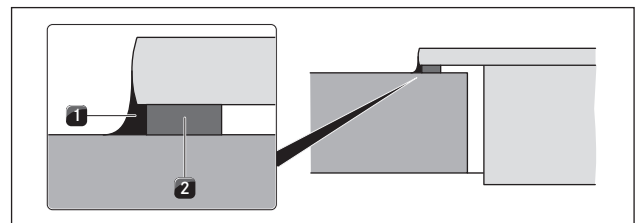

Fig. 6.7 Sealing tape with surface mounting

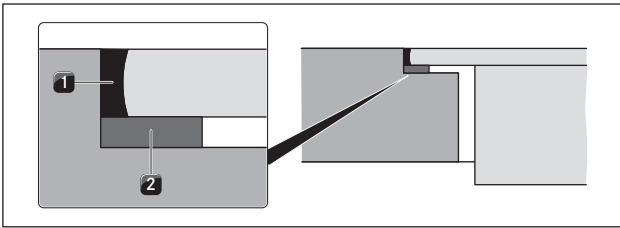

Fig. 6.8 Sealing tape, flush installation

- [1] Black heat-resistant silicone sealing compound  
 [2] Sealing tape

- ▶ With surface mounting, attach the enclosed sealing tape [2] to the underside of the cooktop before installing it. Do not leave any gaps.
- ▶ With flush installation, attach the enclosed sealing tape [2] to the horizontal cutting edge in the worktop cut-out, even if you are sealing the cooktop with a silicone sealing compound [1] or similar.

## 6.6 Installing the recirculation version (BFIU)

**INFO** A minimum clearance of 25 mm must be provided for the vertical return flow aperture.

**INFO** A return flow aperture of at least 500 cm<sup>2</sup> must be provided.

If the cooktop extractor is used exclusively in recirculation mode, operation with an open fireplace is possible without any additional safety measures.

## Installation dimensions

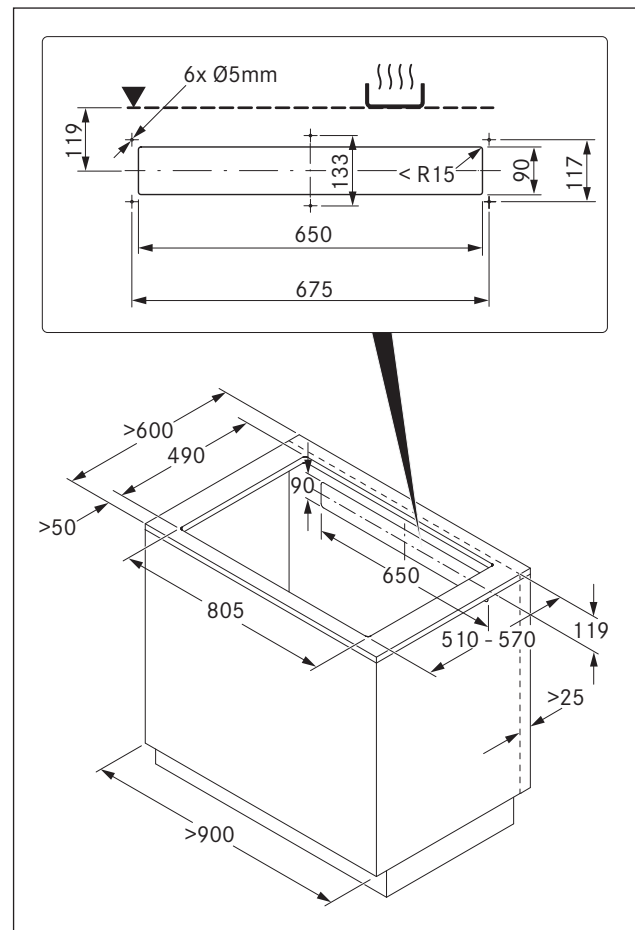

Fig. 6.9 Furniture dimensions for recirculation

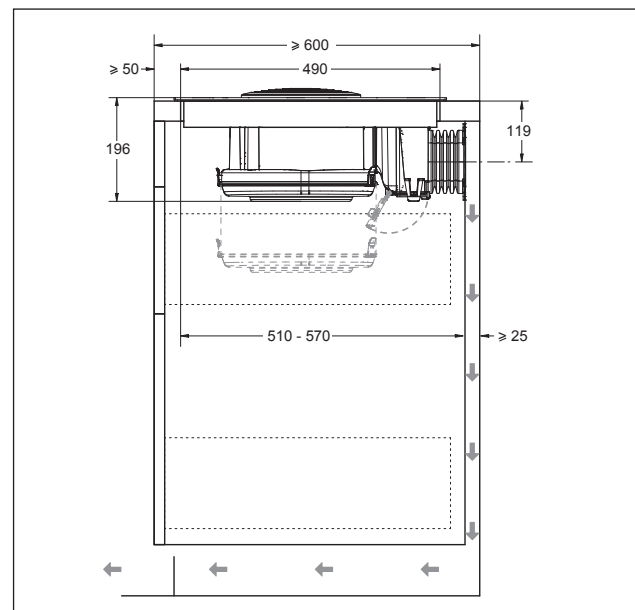

Fig. 6.10 Installation dimensions for recirculation, depth of worktop 600 mm

- The floor unit must have a continuous back wall so that the recirculation air is not directed into the front furniture body compartment.
- There must be a cut-out in the back wall.
- A minimum clearance of 25 mm between the back furniture body wall and an adjacent kitchen unit or room wall must be observed for the return flow aperture.

#### Preparing the back wall of the kitchen unit

- ▶ Adjust the back wall according to the required installation dimensions.
- ▶ If applicable, move the back wall.
- ▶ If necessary, extend the height of the back wall so that the unit is closed to the front.

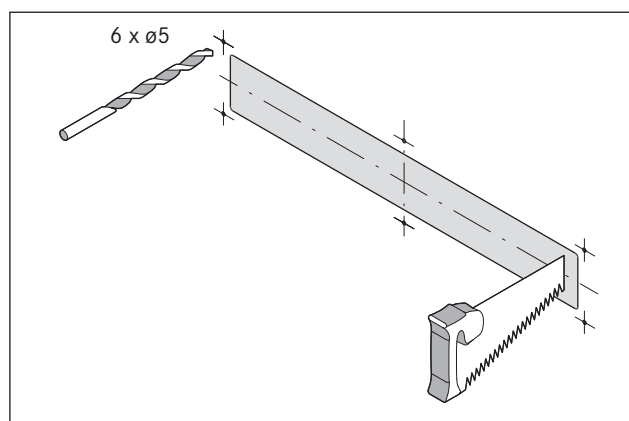

Fig. 6.11 Cut-out and connection requirements

- ▶ In the middle of the cooktop, use the drilling template provided to mark the return flow aperture and the connection drill holes in accordance with the installation dimensions.
- ▶ Saw out the return flow aperture.
- ▶ Drill the connection drill holes.
- ▶ Decrease the height of the skirting boards or create corresponding openings in the plinth.

#### Screwing on the flexible duct

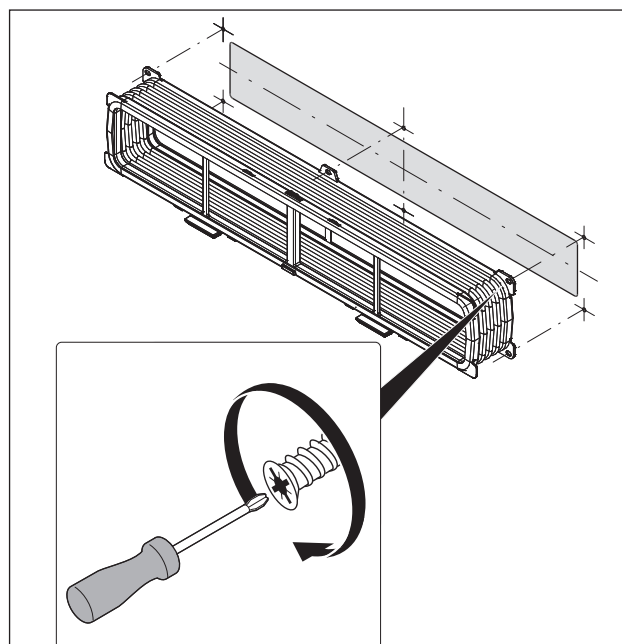

Fig. 6.12 Flexible duct with 6 EURO screws 6.3 x 10 mm

- ▶ Use a screwdriver (not an electric screwdriver) to screw the flexible duct to the back wall of the kitchen unit until it is hand-tight.

#### Inserting the cooktop

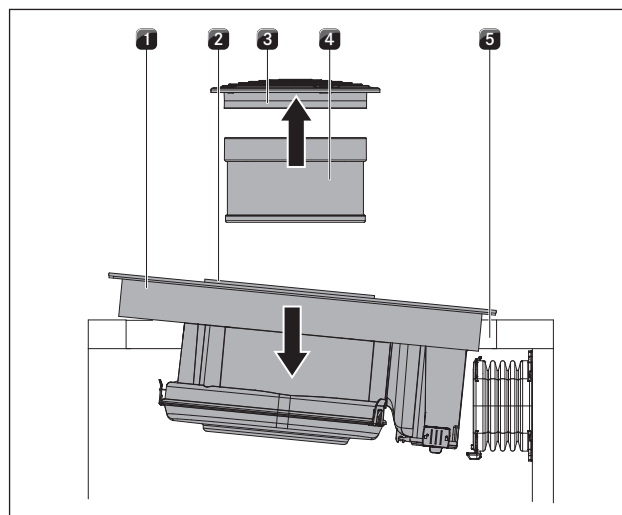

Fig. 6.13 Insert the cooktop obliquely

- [1] Cooktop
- [2] Suction opening
- [3] Air inlet nozzle
- [4] Stainless steel grease filter
- [5] Worktop cut-out

- ▶ Before inserting, remove the air inlet nozzle [3] and the stainless steel grease filter [4].
- ▶ Use the suction opening [2] as a handle when inserting.
- ▶ Lift the cooktop [1] diagonally into the worktop cut-out [5].
- ▶ Place the cooktop [1] in the centre of the worktop cut-out [5].
- ▶ Precisely align the cooktop.

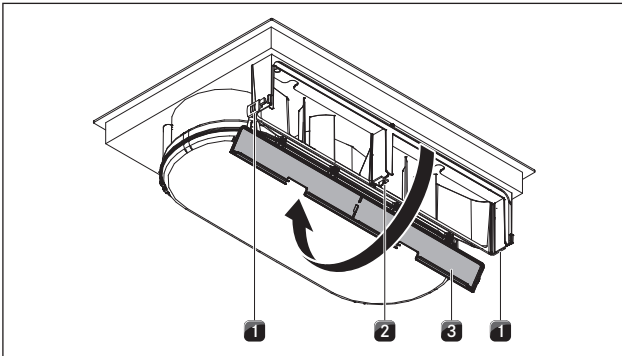

Fig. 6.14 Opening the housing cover

- [1] Outer locks
- [2] Middle lock
- [3] Housing of the activated charcoal filter

- ▶ Fold down the cover of the activated charcoal filter housing [3] from below by opening the two outer locks [1] and the middle lock [2].

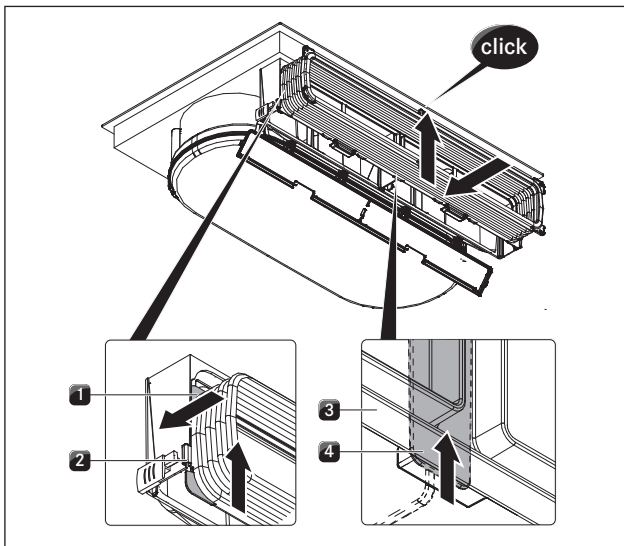

Fig. 6.15 Mounting the frame of the flexible duct

- [1] Position shackles
- [2] Retaining groove on the activated charcoal filter housing
- [3] Flexible duct frame
- [4] Bottom lock

- ▶ Hang the frame of the flexible duct into the retaining groove on the activated charcoal filter housing [2].
- ▶ Make sure that the two lateral position shackles [1] are in the guide.

- ▶ Slide the frame [3] up until the bottom lock [4] and the upper lock engage in the middle.
- ▶ Make sure that the frame is fitted all around in the groove of the activated charcoal filter housing.

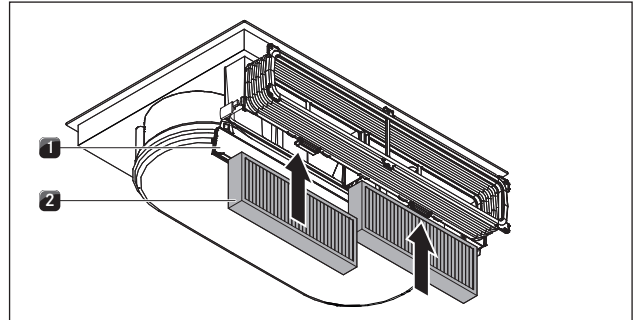

Fig. 6.16 Inserting the activated charcoal filter

- [1] Housing cover of the activated charcoal filter
- [2] Activated charcoal filter

- ▶ Remove the packaging from the activated charcoal filters.
- ▶ Insert the two activated charcoal filters [2] from below.
- ▶ Check the direction of flow of the filters. This is identified by an arrow.
- ▶ Close the housing cover [1].

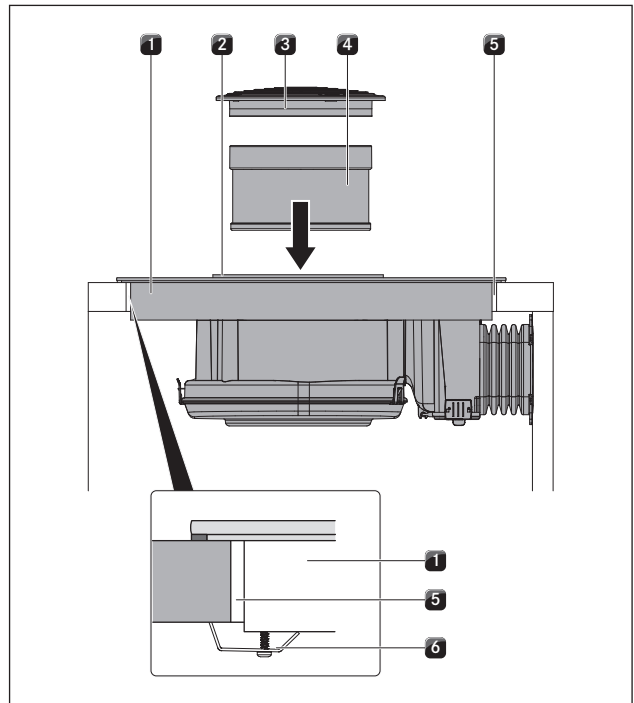

Fig. 6.17 Securing the cooktop in the middle

- [1] Cooktop
- [2] Suction opening
- [3] Air inlet nozzle
- [4] Stainless steel grease filter
- [5] Worktop cut-out
- [6] Mounting bracket



### For surface mounting

- ▶ Make sure that the sealing tape for the cooktop is flat against the worktop.

### For flush installation

- ▶ Make sure that the sealing tape of the cooktop is sealed well all the way round.

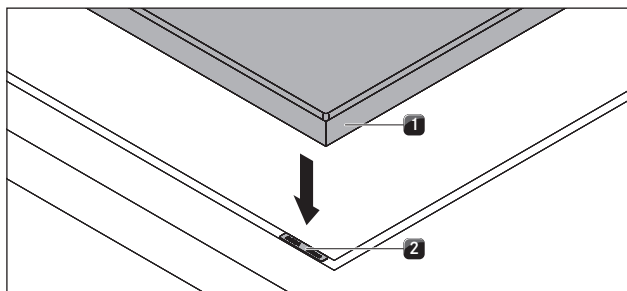

Fig. 6.18 Height adjustment plates

[1] Cooktop

[2] Height adjustment plate

- ▶ If applicable, insert the height adjustment plate [2].
- ▶ Fasten the cooktop to the worktop using the mounting brackets [6].
- ▶ Next, insert the stainless steel grease filter [4] and the air inlet nozzle [3].
- ▶ Seal the surrounding gap with black, heat-resistant silicone sealant.

## 6.7 Installing the exhaust air version (BFIA)

**INFO** The state and regional laws and regulations must be observed with regard to the exhaust duct design. A sufficient air supply must be ensured.

### 6.7.1 Operating the cooktop extractor with a fireplace that depends on the air in the room

Fireplaces that depend on the air in the room (e.g. gas, oil, wood or coal-fired heaters, continuous-flow water heaters, instantaneous water heaters) draw in air from the room in which they are installed and release the exhaust fumes into the outside air via an exhaust system (e.g. chimney).

If the cooktop extractor is used in exhaust mode, it draws in air from the room in which it is installed as well as from neighbouring rooms. If there is insufficient air supply, low pressure will occur. Toxic gases could be drawn out of the chimney or extraction ducting and back into the room.

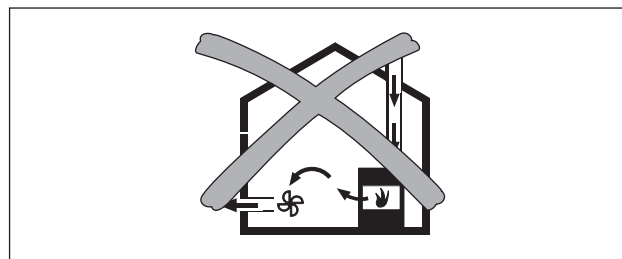

Fig. 6.19 Exhaust air installation – not permitted

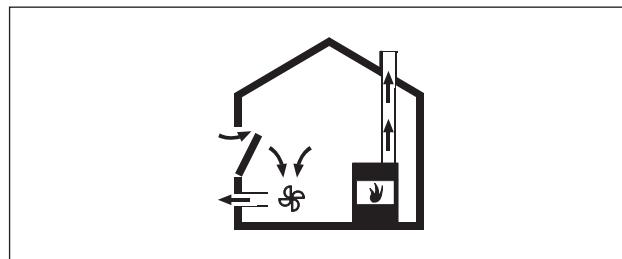

Fig. 6.20 Exhaust air installation – correct

- ▶ If simultaneously operating both a fireplace and the cooktop extractor in the same room, ensure that:
  - the maximum low pressure is 4 Pa ( $4 \times 10^{-5}$  bar);
  - a safety device (e.g. window contact switch, low pressure warning device) is used to ensure that a sufficient supply of fresh air is guaranteed;
  - the exhaust air is not be ducted into a chimney that is used for exhaust gases of devices operated with gas or other combustibles;
  - the installation is checked and approved by an authorised certified engineer (e.g. heating engineer).

### Installation dimensions

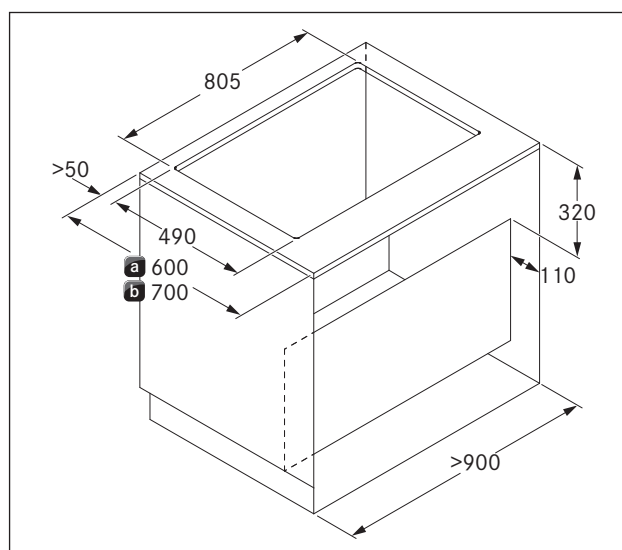

Fig. 6.21 Kitchen unit dimensions with exhaust air

[a] Worktop depth from 600 mm

[b] Worktop depth from 700 mm

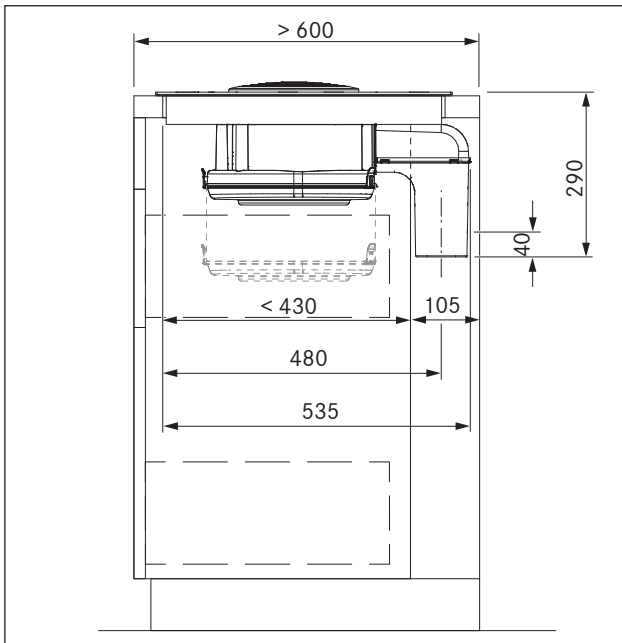

Fig. 6.22 Installation dimensions for exhaust air, worktop depth 600 mm

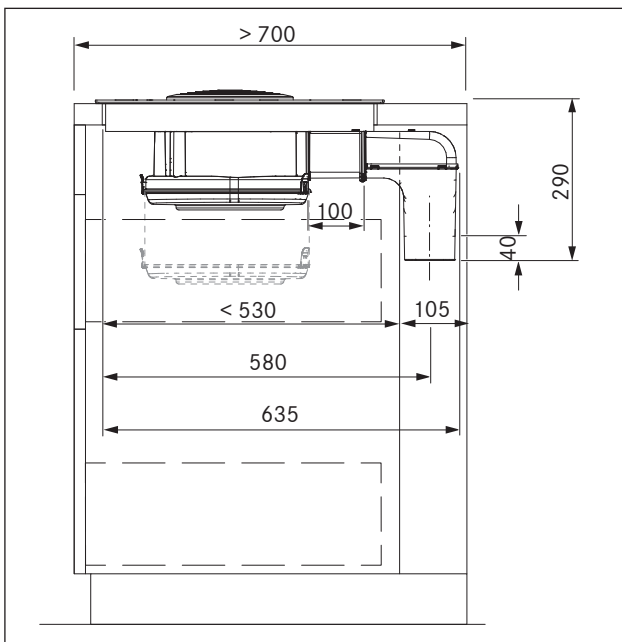

Fig. 6.23 Installation dimensions for exhaust air, worktop depth from 700 mm

#### Installation conditions

- The back wall of the floor unit must be adjusted for the exhaust air duct.
- A minimum clearance of 110 mm between the back furniture body wall and an adjacent kitchen unit or room wall must be observed for the air duct.
- The exhaust air must be directed to the outside in appropriate exhaust air ducts.
- The minimum cross-section of the air ducts must be 176 cm<sup>2</sup>. This corresponds to a round pipe with a diameter of 150 mm.
- The maximum exhaust air duct length is 6 m.

- Planning instructions for the installation of the exhaust air ducts are provided in the BORA ventilation handbook.

#### Preparing the back wall of the kitchen unit

- ▶ Before installation, check the suitability of floor unit with regard to the necessary installation dimensions for the device and the planned duct system.
- ▶ If necessary, adjust the position of the back wall according to the required installation dimensions.

#### Extending the exhaust air duct

**INFO** The exhaust air duct can optionally be extended by 100 mm to the rear using the supplied horizontal extension BLAVH1.

- ▶ Remove the air inlet nozzle and the stainless steel grease filter.
- ▶ Insert the cooktop with the glass ceramic panel facing downward on a clean and soft surface (e.g. cardboard, packaging material) in order to avoid damage to the glass ceramic panel.

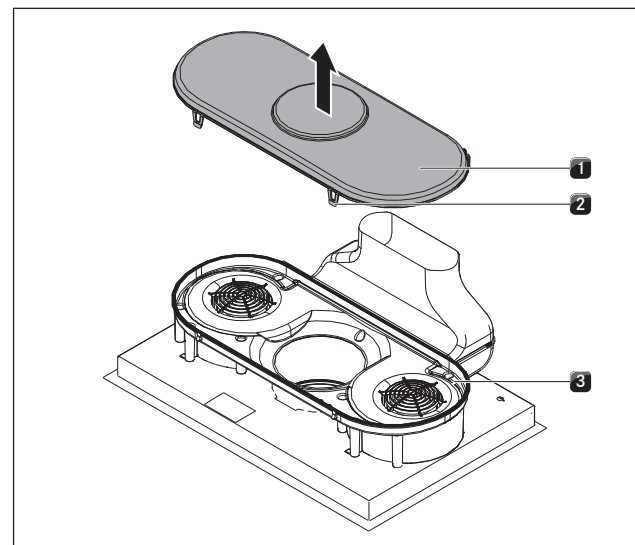

Fig. 6.24 Removing the housing base

- [1] Housing base
- [2] Locks
- [3] Air guiding housing

- ▶ Open the 4 locks [2].
- ▶ Remove the housing base [1] from the air guiding housing [3].

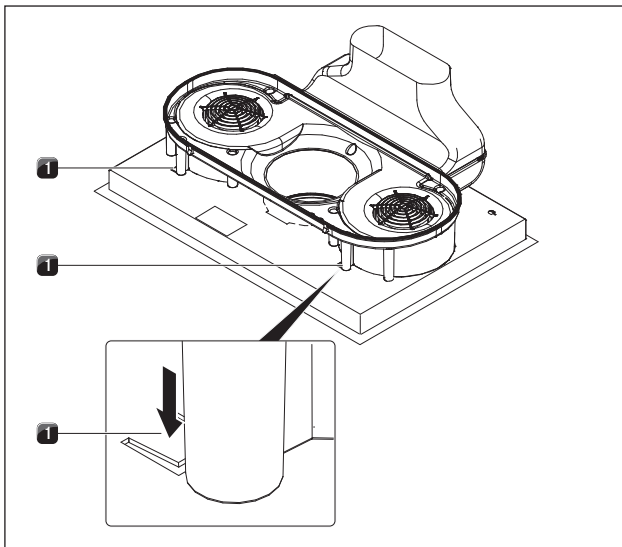

Fig. 6.25 Unlocking the position lock

[1] Shackles for position lock

- Use a screw driver to press the shackles left and right [1] downward to unlock the position lock.

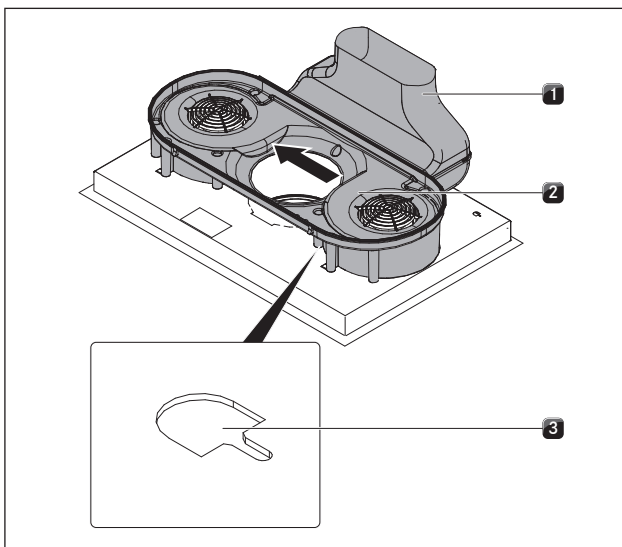

Fig. 6.26 Moving the air guiding housing

[1] Exhaust air arc  
[2] Air guiding housing  
[3] Insertion aperture

- Move the air guiding housing [2] laterally together with the exhaust air arc [1] to the left edge of the insertion aperture [3].

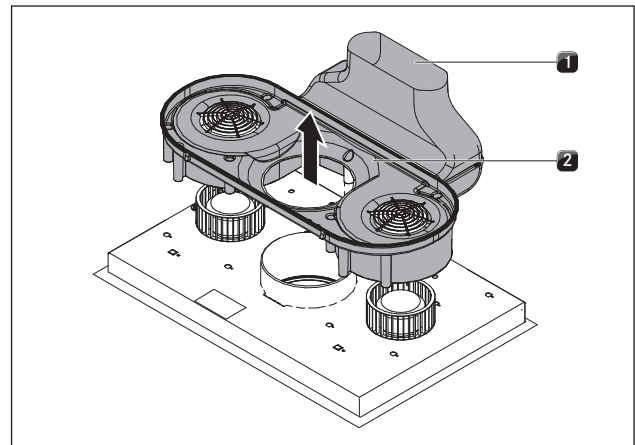

Fig. 6.27 Removing the air guiding housing

[1] Exhaust air arc  
[2] Air guiding housing

- Remove the air guiding housing [2] with the exhaust air arc [1] upward.

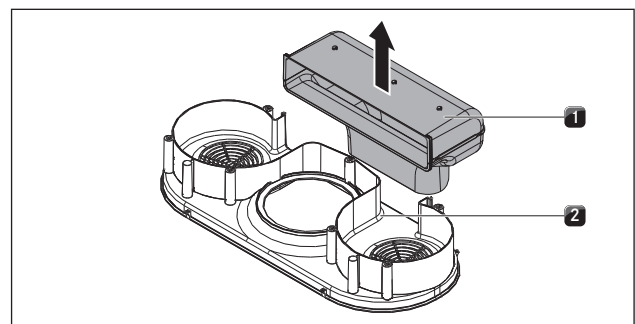

Fig. 6.28 Removing the exhaust air arc

[1] Exhaust air arc  
[2] Air guiding housing

- Remove the exhaust air arc [1] from the air guiding housing [2] upward.

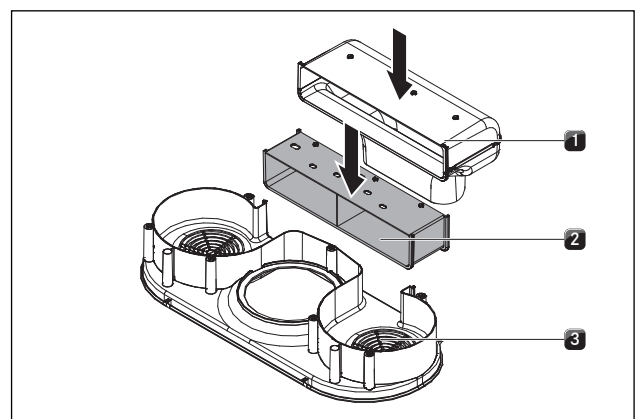

Fig. 6.29 Inserting the air duct extension

[1] Exhaust air arc  
[2] Exhaust air duct extension  
[3] Air guiding housing

- ▶ Insert the exhaust air duct extension [2] into the groove of the air guiding housing [3].
- ▶ Insert the exhaust air arc [1] into the groove of the exhaust air duct extension [2].

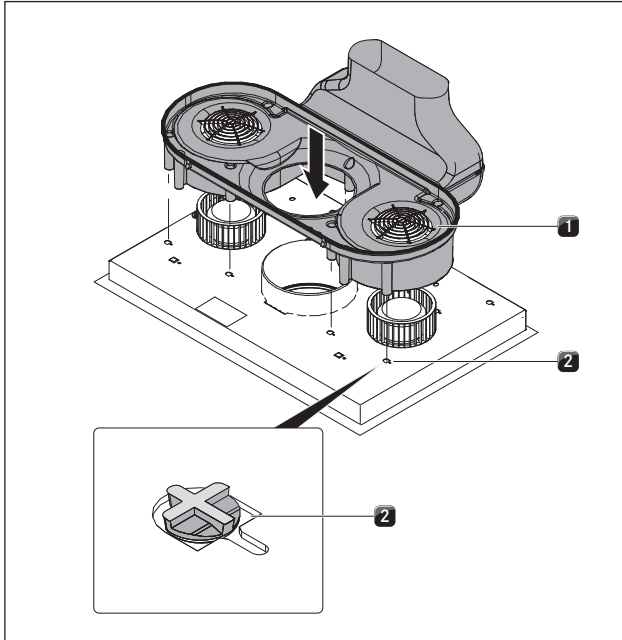

Fig. 6.30 Placing the airflow assembly on the cooktop base

- [1] Airflow assembly
- [2] Openings

- ▶ Position the airflow assembly [1] on the cooktop base in such a way that all retaining hooks fit into the openings [2].

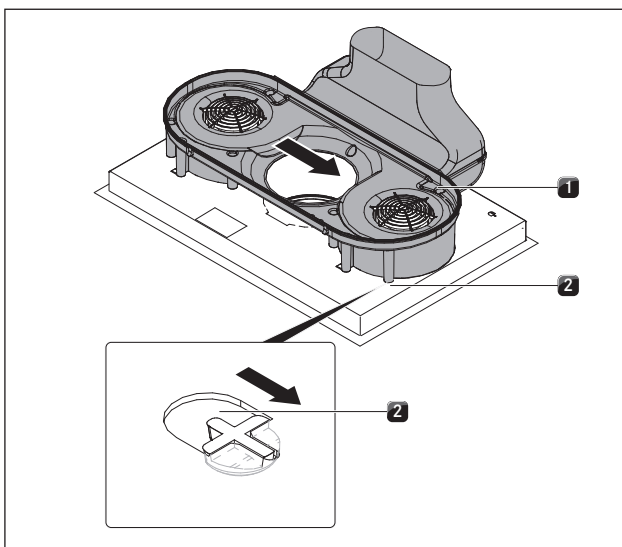

Fig. 6.31 Engaging the airflow assembly

- [1] Airflow assembly
- [2] Openings

- ▶ Now move the airflow assembly [1] to the right until it is fully engaged in the opening slot [2].

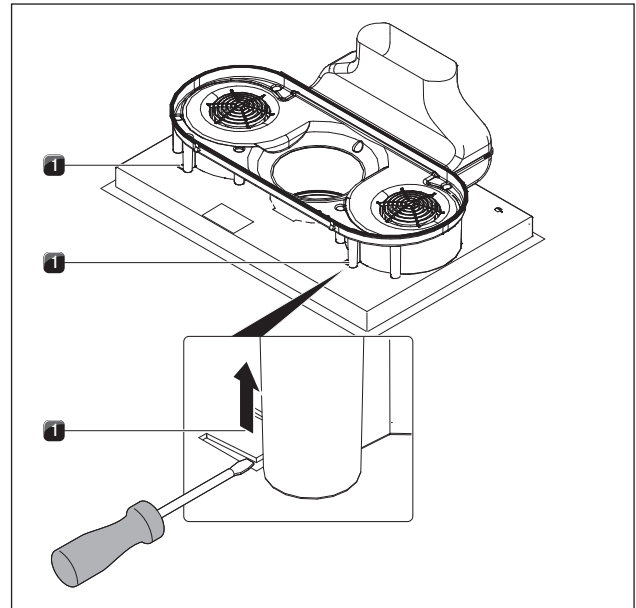

Fig. 6.32 Position lock

- [1] Shackles for transportation and position lock

- ▶ Press the two shackles [1] for the position lock upward.
- ▶ Raise the cooktop with integrated cooktop extractor.
- ▶ Turn the glass ceramic side upward.

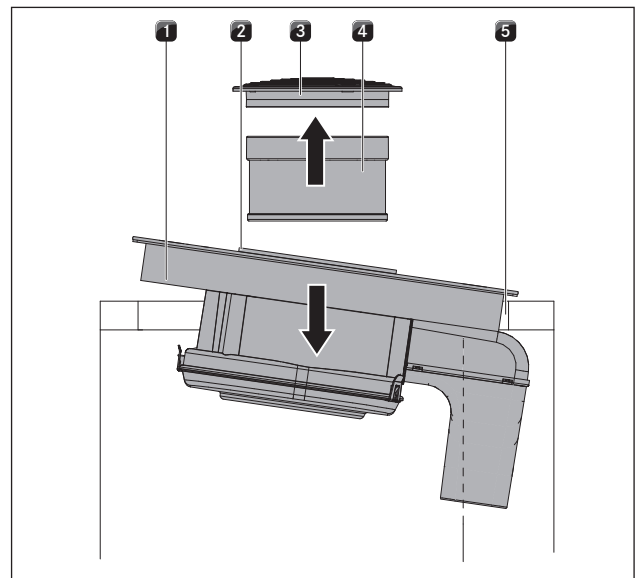

Fig. 6.33 Inserting the cooktop

- [1] Cooktop
- [2] Suction opening
- [3] Air inlet nozzle
- [4] Stainless steel grease filter
- [5] Worktop cut-out

- ▶ Use the suction opening [2] as a handle during insertion.
- ▶ Hold the suction opening [2].
- ▶ Insert the cooktop in the middle of the worktop cut-out [5].
- ▶ Precisely align the cooktop.

**For surface mounting**

- ▶ Make sure that the sealing tape is resting on the worktop.

**For flush installation**

- ▶ Make sure that the sealing tape of the cooktop is sealed well all the way round.

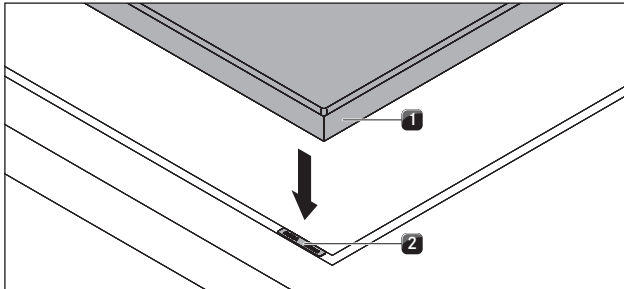

Fig. 6.34 Height adjustment plates

- [1] Cooktop
- [2] Height adjustment plate

- ▶ If applicable, insert the height adjustment plate [2].

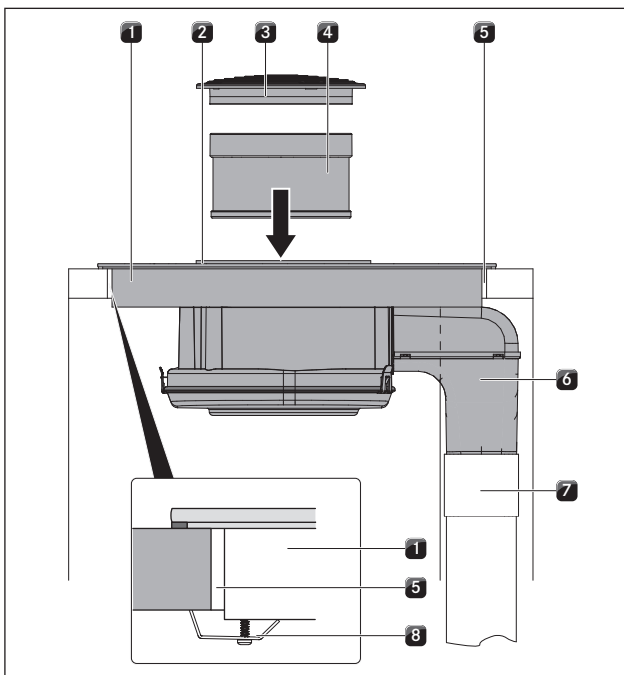

Fig. 6.35 Connect the air duct + secure

- [1] Cooktop
- [2] Suction opening
- [3] Air inlet nozzle
- [4] Stainless steel grease filter
- [5] Worktop cut-out
- [6] Exhaust air arc
- [7] Exhaust air duct
- [8] Mounting bracket

- ▶ Connect the exhaust air duct [7] at the installation site to the exhaust air arc [6].
- ▶ Seal the duct connection so that it is airtight using adhesive sealing tape UDB 1.

- ▶ Fasten the cooktop to the worktop using the mounting brackets [8].
- ▶ Next, insert the stainless steel grease filter [4] and the air inlet nozzle [3].
- ▶ Seal the surrounding gap with black, heat-resistant silicone sealant.

**6.8 Establishing the power connection**

- ▶ Observe all safety and warning information (see the Safety chapter).
- ▶ Observe all national and regional laws and regulations as well as the supplementary regulations of the local utility companies.

**INFO** The power connection may only be established by certified specialists. He/she also assumes responsibility for the proper installation and commissioning.

**INFO** Connections via plug-in contacts (Schuko plugs) are not permitted.

**INFO** The device complies with IEC 6 1000-3-12

- ▶ Switch off the main switch/automatic circuit breaker before connecting the cooktop.
- ▶ Protect the main switch/automatic circuit breaker from being switched on without permission.
- ▶ Make sure the device is not energised.
- ▶ Connect the cooktop exclusively via a fixed connection to an H 05 VV-F power supply cable with corresponding minimum cross-section (see tab. Fuse protection and minimum cross-section).

Connection	Fuse protection	Minimum cross-section
3-phase connection	3 x 16 A	2.5 mm <sup>2</sup>
2-phase connection	2 x 16 A	2.5 mm <sup>2</sup>
1-phase connection	1 x 32 A	4 mm <sup>2</sup>

Tab. 6.2 Fuse protection and minimum cross-section

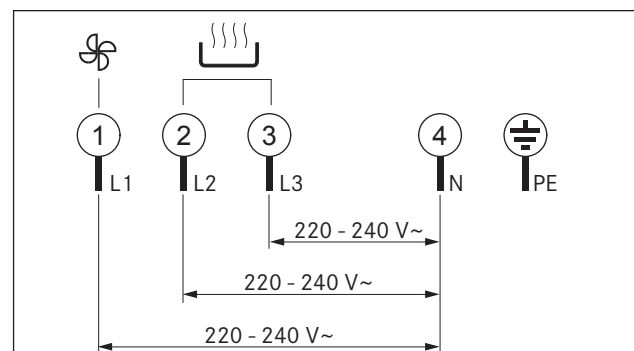

Fig. 6.36 Connection diagram 3-phase connection

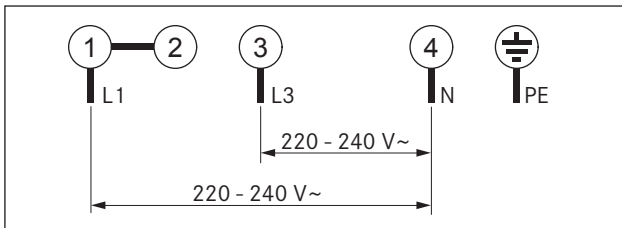

Fig. 6.37 Connection diagram 2-phase connection

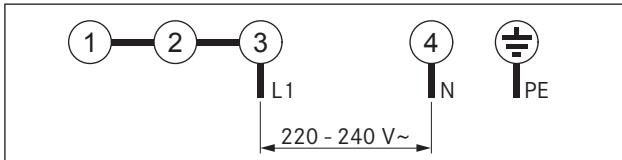

Fig. 6.38 Connection diagram 1-phase connection

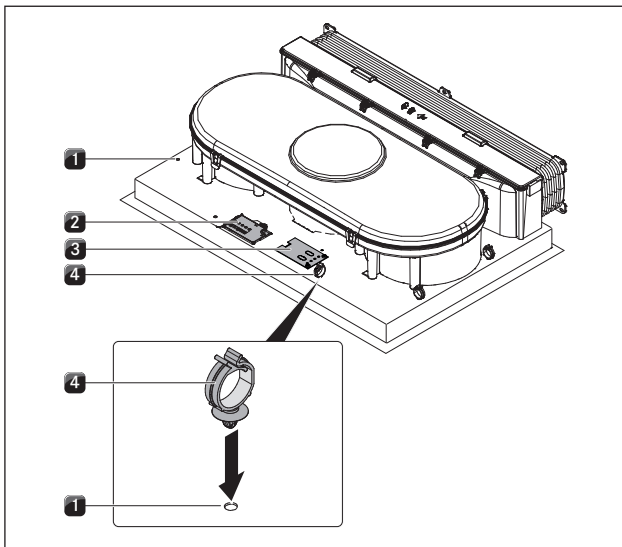

Fig. 6.39 Electrical connections of the cooktop

- [1] Bore holes
- [2] Power supply
- [3] Connection control
- [4] Cable mounting clip

- ▶ Connect the power supply cable to the power supply [2] of the cooktop with cooktopFig. 6.36r in accordance with the relevant connection diagram (see fig. 6.36 Connection diagram).
- ▶ For a 1-phase or 2-phase connection, connect the relevant contacts with the BKAS connector clip (in scope of delivery).
- ▶ Fasten the cable mounting clips [3] to the designated bore holes [1] either on the left or right hand side for the cable routing to the rear.
- ▶ Ensure that the cable is not caught or damaged and is not able to touch any hot hobs.
- ▶ Verify that the installation was done correctly.
- ▶ Switch on the main switch/automatic circuit breaker.
- ▶ Put the cooktop into operation (see the Operation chapter).
- ▶ Check all the functions are working correctly.

## 6.9 Device power management (overall power reduction)

**INFO** The device power management function can be set in the service menu. Accessing the service menu and changing the power management setting may only be performed by a certified specialist.

The total device power can be reduced to 4.4 kW upon initial commissioning if the required electrical power cannot be provided at the installation site. The connection must always be equipped with 20 A fuse protection as a minimum.

### Programming the device power management

#### Prerequisites:

- The cooktop is switched off.
- All cooking zones are switched off.
- ▶ Separate the device from the voltage supply using the LS switch, fuses, automatic circuit breakers or contactors.
- After re-establishing the voltage supply, you have up to two minutes to open the service menu.
- ▶ Re-connect the appliance to the voltage supply.
- ▶ Press and hold the multi-function button.
- ▶ Briefly press the timer button.
- A short signal tone will sound and the front half of the setting ring lights up.
- ▶ Now release the multi-function button.
- ▶ Swipe the setting ring in a circular, clockwise motion to move from 3 to 8.

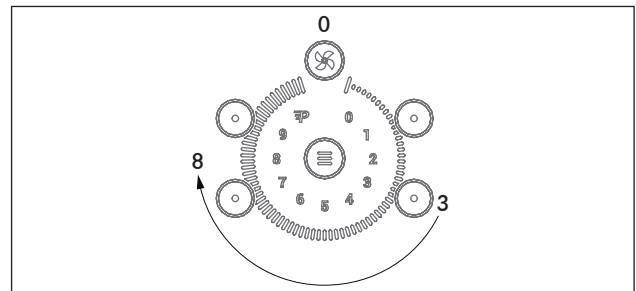





Fig. 6.40 Opening the service menu

- is displayed intermittently with and on the left front cooking zone indicator.
- is displayed in the left back cooking zone indicator (factory setting).
- ▶ Use the multi-function button to select the menu level .
- ▶ Press any key at the adjusting ring to change the setting of the back left cooking zone from to .
- ▶ Press the timer button to save the change.
- The cooktop is ready for use.

Menu setting 	Cooking zone power	
	Left side	Right side
	3.7 kW	3.7 kW
	2.2 kW	2.2 kW

Tab. 6.3 Device power management

## 6.10 Connect the external switch contact

**INFO** The Home-In and Home-Out communication connection must only be connected by a certified specialist. He/she also assumes responsibility for the proper installation and commissioning.

When using Home-In and Home-Out, you will require the relevant documents for the external switching devices in order to ensure safe device connection and operation.

The following switch connections can be used:

Contact	Function	Connection
Home-In	Cooktop extractor on/off connection for external switch contact (contact closed: cooktop extractor on)	30 V DC 0.7 mA
Home-Out	Electrically isolated contact for controlling external installations depending on the operation of the cooktop extractor (cooktop extractor on: contact closed)	Maximum 250V/4A

Tab. 6.4 Home-In and Home-Out switch connections

**INFO** The Home-In contact can be used for external safety devices (e.g. window contact switches). If the switch is open, the cooktop extractor is out of operation.

**INFO** Shielded cable must be used for cabled window contact switches. The shield for this cable must not come into contact with the earth wire of the device (cooktop).

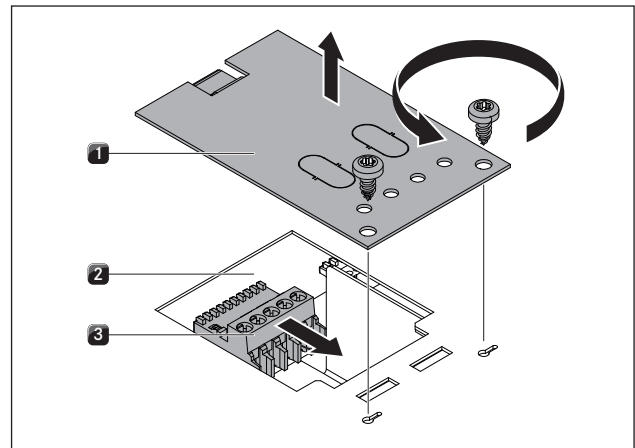

Fig. 6.41 Opening the cover and disconnecting the contact plug

- [1] Cover
- [2] Electronic unit
- [3] Contact plug

- ▶ Open the cover [1].
- ▶ Adhere to the connection diagram when connecting Home-In and Home-Out.
- ▶ Disconnect the contact plug [3] from the electronic unit [2].

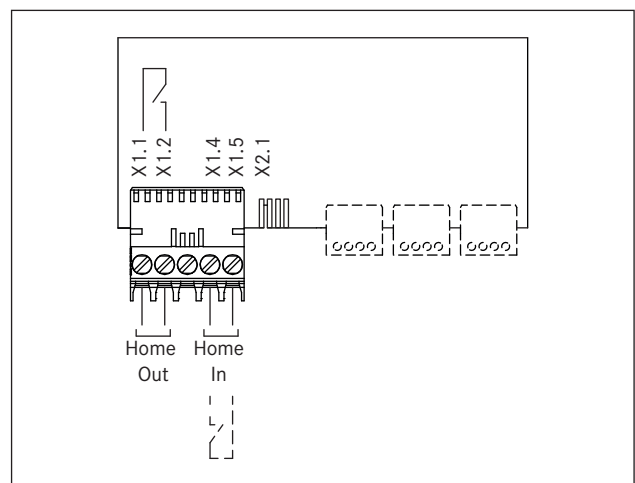

Fig. 6.42 External switch contacts connection diagram

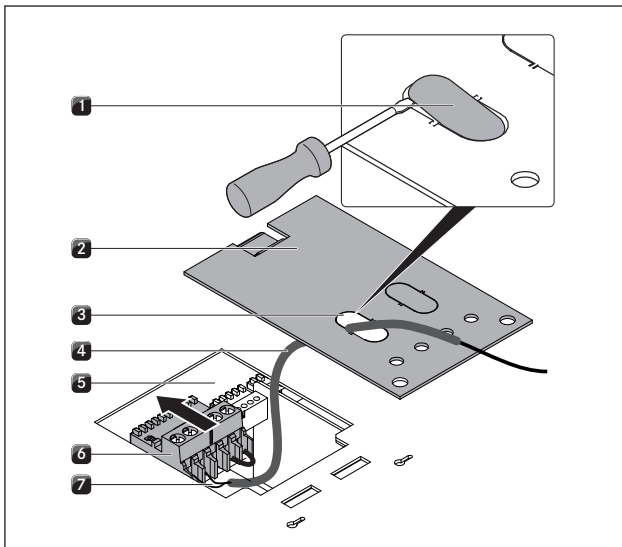

Fig. 6.43 Connecting the cable

- [1] Sealing cover
- [2] Cover
- [3] Cable opening
- [4] Protective hose
- [5] Electronic unit
- [6] Contact plug
- [7] Cable connection

- ▶ Remove the sealing cover [1] for the cable opening [3] with a screw driver.
- ▶ Move the protective hose [4] onto the cable [7].
- ▶ Guide the cable [7] with the protective hose [4] through the cable opening [3] in the cover.
- ▶ Remove the installed bridge.
- ▶ Connect the cable for the relevant contact to the contact plug [6] in accordance with the relevant connection diagram (see fig. Connection diagram for external switch contacts).

**INFO** The Home-In contact must be bridged if this is not used (bridged on delivery).

- ▶ Connect the contact plug [6] to the electronic unit [5].
- ▶ Ensure that the protective hose [4] is located directly on the contact plug [6] and that the protective hose [4] goes through the opening [3] in the cover [2].

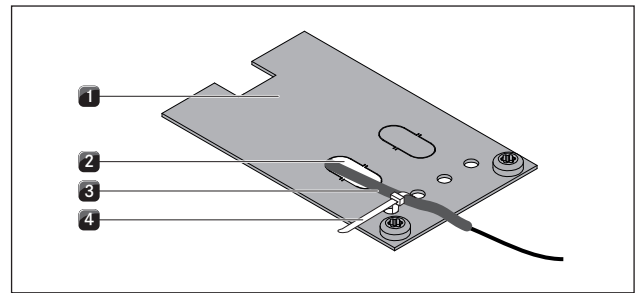

Fig. 6.44 Attaching tension relief

- [1] Cover
- [2] Cable opening
- [3] Protective hose
- [4] Cable tie

- ▶ Attach the cable tie [4] to the cover [1]. However, do not yet tighten the cable tie.
- ▶ Avoid tension on the cable.
- ▶ Close the cover [1].
- ▶ Tighten the cable tie [4] (tension relief).
- ▶ Ensure that the cable is not caught or damaged and is not able to touch any hot hobs.
- ▶ Verify that the installation was done correctly.
- ▶ Switch on the main switch/automatic circuit breaker.
- ▶ Put the cooktop extractor into operation (see the Operation chapter).
- ▶ Check all the functions are working correctly.

## 6.11 Handover to user

Once installation is done:

- ▶ Explain the important functions to the user.
- ▶ Explain all safety-relevant aspects of operation and handling to the user.
- ▶ Provide the user with the accessories and operating and installation instructions to be kept in a safe place.



## 7 Operation

- ▶ Observe all safety and warning information during operation (see the Safety chapter).

**INFO** Only operate the cooktop if the stainless steel grease filter and the air inlet nozzle have been installed.

### 7.1 General operating instructions

The cooktop or cooktop extractor is operated using the operating panel.

The selection of the cooking zone is performed by the direct selection of the assigned sensor button on the operating panel.

There are 9 power levels and one power setting available for each cooking zone and the cooktop extractor.

The selection on the setting ring is performed by direct selection or by uniformly swiping clockwise or anti-clockwise.

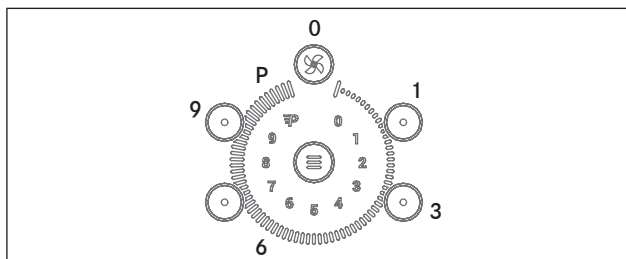

Fig. 7.1 Setting ring with power level positions

### 7.2 Operating the cooktop

#### Switching on

**INFO** If the display shows  $\square$  and no other input is made, the device will switch off automatically after 20 seconds.

- ▶ Press the on/off switch  $\text{I}$  to switch on the device.
- The power level  $\square$  is shown on the display.

#### Switching off

**INFO** Use the operating panel to switch off the cooking zone after use. Do not rely on the pan size recognition.

- ▶ Press the on/off switch  $\text{I}$  to switch off the device.
- ▶ Pay attention to the residual heat display (see the Device Description chapter).

#### 7.2.1 Select cooking zone

- ▶ Press the cooking zone button for the desired cooking zone.
- The  $\square$  in the cooking zone indicator lights up more brightly.

#### 7.2.2 Adjusting the power level

- ▶ Press the desired power level or
- ▶ Press and uniformly swipe round the setting ring until the desired power level is reached.

#### 7.2.3 Changing the power level

- ▶ Press the cooking zone button for the desired cooking zone.
- The cooking zone indicator lights up more brightly.
- ▶ Select the desired power level.

#### 7.2.4 Selecting the power setting

- ▶ Press the cooking zone button for the desired cooking zone.
- The cooking zone indicator lights up more brightly.
- ▶ Select power setting  $P$ .
- The power setting  $P$  is displayed in the cooking zone indicator.

If one cooking zone is operated with the  $P$  power setting, then the operation of the second cooking zone on this side is possible at a maximum of power level  $5$ . If power level  $5$  is increased, the  $P$  power setting is switched off.

#### 7.2.5 Switching the power setting off early

- ▶ Press the cooking zone button for the desired cooking zone.
- The cooking zone indicator lights up more brightly.
- ▶ Select another power level.
- The current power level is displayed in the cooking zone indicator and the power setting is deselected.

#### 7.2.6 Switching off the cooking zone

- ▶ Press the cooking zone button for the desired cooking zone.
- The cooking zone indicator lights up more brightly.
- ▶ Press the power level position  $\square$ .
- ▶  $\square$  will appear on the display for a few seconds, then the display will turn off.

#### 7.2.7 Pay attention to the residual heat display

After switching it off, the cooking zone remains hot.  $H$  is displayed in the cooking zone indicator (residual heat display). The cooking zone indicator will go out after sufficient cooling time (temperature  $< 60^{\circ}\text{C}$ ).

**INFO** While  $H$  is displayed in the cooking zone indicator (residual heat display), do not touch the cooking zone or place any heat-sensitive objects on top of it. Risk of burns and fire!

- ▶ Pay attention to the residual heat display.
- ▶ Be careful not to touch or place objects on hot hobs.

### 7.2.8 Pause function

#### Switching on the pause function

##### Prerequisite

- At least one cooking zone is in use.

**INFO** The pause function switches off automatically after 10 minutes.

- ▶ Press and hold the multi-function button  for approx. 2-3 seconds.
- If there is no input, the display will turn off after 5 seconds.
- ▶ Swipe the setting ring in a circular, clockwise motion to move from 1 to P.

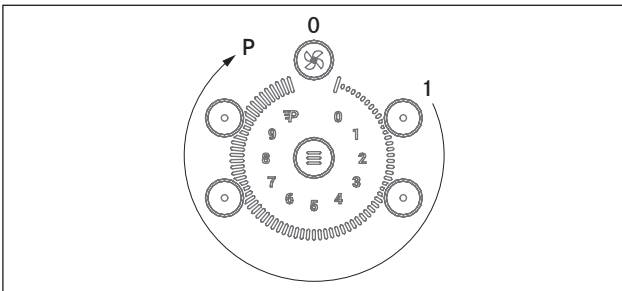



Fig. 7.2 Switching on the pause function

- The segments are displayed on the circular display in accordance with the position.
-  appears in all the cooking zone indicators and two short successive beeps confirm activation.
- The pause function is activated.
- The cooktop extractor remains in operation at a lower power level.

#### Switching off the pause function

- ▶ Press the multi-function button .
- If there is no input for 10 seconds, the pause function will continue.
- The setting ring will show the last segment.
- ▶ Swipe the setting ring in a circular, anticlockwise motion to move from P to 1.

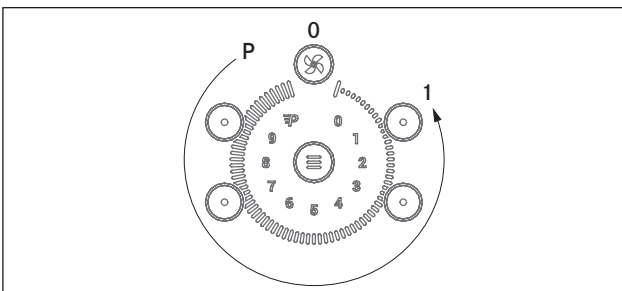

Fig. 7.3 Switching off the pause function



- The segments are displayed on the circular display in accordance with the position.
- All displays will show the power level that was originally set.
- The pause function is deactivated.

### 7.2.9 Bridging function

If the bridging function is active, two cooking zones will operate at the same time on the same cooking level. The front cooking zone will also control the rear, bridged cooking zone.

#### 7.2.10 Switching on the bridging function

##### Prerequisite

- The cooktop is switched on.
- All cooking zones are switched off.
- ▶ Select the front cooking zones and hold down the cooking zone selection button.
- After 2 seconds, the rear cooking zone indicator will show  and there will be a beep.
- ▶ Press the cooking zone selection button for the rear cooking zone to activate the bridging function.
- ▶ Set a power level on the front cooking zone within 3 seconds.
- The bridging function is activated and the rear cooking zone indicator shows .
- If there is no input within 3 seconds, the bridging function will end.



#### 7.2.11 Switching off the bridging function

- ▶ Switch the power level of the front cooking zone to .
- After 3 seconds, the bridging function is deactivated.

### 7.2.12 Automatic heat up function

#### Switching on the automatic heat up function

##### Prerequisite

- The cooktop is switched on.
- A cooking zone is switched on.
- ▶ The automatic heat up function is activated if you press and hold the desired continuous cooking level (1 to 8) for 2 seconds.
- The cooking zone indicator will display the symbol  to show that the automatic heat up function is activated, as well as the continuous cooking level set, for example .

#### Changing the automatic heat up function

The power level of the continuous cooking level can be changed within 15 seconds of activation.

- ▶ Select the cooking zone.
- ▶ Select the desired power level.
- ▶ The selected continuous cooking level, e.g. , appears in the cooking zone indicator.



After the end of the automatic heat up function (see the Device Description chapter), the cooking session will continue with the desired continuous cooking level, e.g. 7.

### 7.2.13 Switching off the automatic heat up function

The activated automatic heat up function will end prematurely if you

- ▶ change the power level;
- ▶ activate the power setting P;
- ▶ activate the heat retention level  $\cup$ ;
- ▶ switch off the cooktop using the on/off switch .

### 7.2.14 Heat retention level

- The cooktop is switched on.
- ▶ Select a cooking zone.
- ▶ Press the multi-function button  several times to increase the heat retention level.
- The cooking zone indicator will display the relevant heat retention level, e.g. 2.
- ▶ Press the multi-function button  again.
- The heat retention level is deactivated.
- The cooking zone will automatically switch off after 8 seconds.

### 7.2.15 Using the timer function

**INFO** The relevant timer control light shows whether the timer is activated. The timer control light lights up until the cooking zone has automatically switched off after the pre-set time has passed.

#### Prerequisite

- The cooktop is switched on.

You can use 2 timer functions:

- Short-time timer (egg timer – cooking zone does not switch off automatically).
- Automatic cut-off (for automatically switching off a cooking zone).

You can set a time range of between 1 and 99 minutes for both timer functions.



**INFO** After the end of the time set, 00 will appear in the time display for a few seconds and the dot in the display or the relevant timer control light will flash. A signal tone will sound for a few seconds.

- The signal tone and the flashing are automatically deactivated after 2 minutes.

### 7.2.16 Switching the signal beep off early

- ▶ Press any sensor button on the operating panel to end the signal tone prematurely.

### 7.2.17 Setting the short-time timer (egg timer)

- ▶ Press the timer button .
- 00 will appear in the timer display for a few seconds and the dot below the display will flash.
- If there is no input, the timer display will turn off after 10 seconds.
- ▶ Press the timer button  multiple times to increase the duration by +10 minutes each time.
- ▶ Change the minutes in the timer display by making a selection on the setting ring.
- Once the desired time has been selected, the timer starts automatically.

### 7.2.18 Switching off the short-time timer (egg timer) early

You can switch off the short-time timer early by

- ▶ changing the remaining timer setting to  $\cup\cup$ .



### 7.2.19 Setting the automatic cut-off

You can set an automatic cut-off for every cooking zone.

**INFO** If several cooking zones are activated with an automatic cut-off, the lowest timer value will be shown and the timer control light for the cooking zone in question will light up more brightly.

#### Prerequisite

- A cooking zone has been selected.
- A power level was set.

- ▶ Select the desired cooking zone.
- ▶ Press the timer button  within 3 seconds.
- 00 will appear in the timer display for a few seconds and the dot next to the display will flash.
- ▶ Press the timer button  multiple times to increase the duration by 10 minutes each time.
- ▶ Change the minutes in the timer display by making a selection on the setting ring.
- Once the desired time has been selected, the timer starts automatically.

After the last input, the set time will be displayed in the timer display for a few seconds.

### 7.2.20 Switching off the automatic cut-off early

The activated automatic cut-off function will end early if you

- ▶ change the remaining timer setting to  $\cup\cup$ ;
- ▶ switch off the cooktop using the on/off switch .
- ▶ Change the power level to 0.

### 7.2.21 Changing the timer settings

- ▶ Press the cooking zone button for the cooking zone for which you wish to change the automatic cut-off.
- ▶ Press the timer button  multiple times to increase the duration by 10 minutes each time.
- ▶ Change the minutes in the timer display by uniformly swiping the setting ring.

### 7.2.22 Switching the childproofing feature on/off

**INFO** If a cooking zone indicator alternates between displaying  $L$  and  $H$ , the cooking zone is still hot.

#### Switching on the childproofing feature

**Prerequisites:**

- The cooktop is switched on.
- All cooking zones are switched off.
- ▶ Press and hold the multi-function button  for approx. 2-3 seconds.
- If there is no input, the display will turn off after 5 seconds.
- ▶ Swipe the setting ring in a circular, clockwise motion to move from 1 to P.

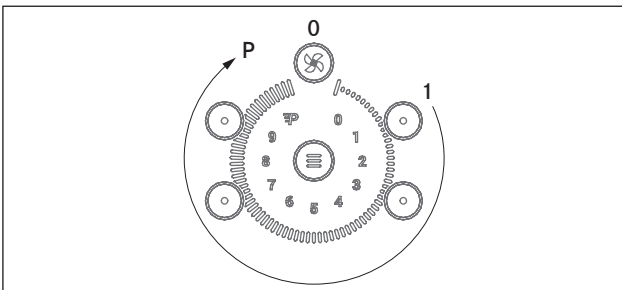



Fig. 7.4 Switching on the childproofing feature

- The segments are displayed on the circular display in accordance with the position.
- $L$  is displayed in all cooking zone indicators.
- The childproofing feature is activated.

#### Switching off the childproofing feature

- The cooktop is switched on.
- ▶ Press and hold the multi-function button  for approx. 2-3 seconds.
- The setting ring will show the last segment.
- ▶ Swipe the setting ring in a circular, anticlockwise motion to move from P to 1.

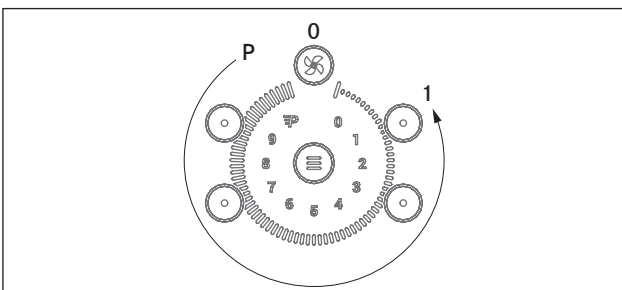

Fig. 7.5 Switching off the childproofing feature

- The segments are displayed on the circular display in accordance with the position.
- All cooking zone indicators display  $H$ .
- The childproofing feature is deactivated.

The power level you require can now be set for each cooking zone.

## 7.3 Operating the cooktop extractor

**Prerequisite:**

- The cooktop with integrated cooktop extractor is switched on.

**Recommendations for efficient vapour extraction:**

- ▶ Always use a lid on pots that are particularly high. This ensures effective vapour extraction. It also reduces power consumption.
- ▶ Only operate the cooktop extractor at the minimum power level required for an effective vapour extraction. This enables you to improve the performance of the odour filters in recirculation mode.
- ▶ Only operate the hob at the minimum power level required for cooking. This reduces the cooking vapours and the power consumption.
- ▶ Avoid strong drafts.

### 7.3.1 Selecting a cooktop extractor

- ▶ Press the selection button for the cooktop extractor.
- The  $P$  in the cooking zone indicator lights up more brightly.

### 7.3.2 Adjusting the power level

- ▶ Press the desired position on the setting ring to set the power level or
- ▶ Press and uniformly swipe round the setting ring until the desired power level is reached.

### 7.3.3 Changing the power level

- ▶ Press the selection button for the cooktop extractor.
- The fan display lights up more brightly.
- ▶ Select the desired power level.
- The set power level is displayed in the fan display.

### 7.3.4 Selecting the power setting

- ▶ Press the selection button for the cooktop extractor.
- The fan display lights up more brightly.
- ▶ Select power setting  $P$ .
- The power setting  $P$  is displayed in the cooking zone indicator.
- The power setting  $P$  automatically switches to power level  $9$  after 10 minutes.

### 7.3.5 Automatic cooktop extractor function

**INFO** If the automatic cooktop extractor function is activated, the power level can be changed. The automatic cooktop extractor function will be reactivated after 10 minutes.

- ▶ Press the selection button for the cooktop extractor.
- ▶ Press the multi-function button .
- The fan display lights up more brightly.
- The automatic cooktop extractor function is activated.
- $A$  appears on the display.

### 7.3.6 Switching off the automatic cooktop extractor function

- ▶ Press the selection button for the cooktop extractor.
- ▶ Press the multi-function button .
- The automatic cooktop extractor function is deactivated.

### 7.3.7 Automatic after-run

- ▶ Press the selection button for the cooktop extractor.
- The fan display lights up more brightly.
- ▶ Select power level .
- The power level  $n$  is shown on the display.
- The cooktop extractor switches off automatically after 20 minutes.

### 7.3.8 Switching off the automatic after-run early

- ▶ Press the selection button on the cooktop extractor while the automatic after-run is active.
- The automatic after-run is switched off.

### 7.3.9 Switching off the cooktop extractor

- ▶ Press the selection button for the cooktop extractor.
- The fan display lights up more brightly.
- ▶ Select power level .
- The power level  $n$  is shown on the display.
- ▶ Press the selection button for the cooktop extractor again.
- The device switches off.

or

- ▶ Press the on/off switch  to switch off the device.

---

**INFO** If the automatic cooktop extractor function is activated when switching off, it will remain active the next time the extractor is switched on.

---

## 7.4 Pay attention to the filter service display

If  $F$  appears on the fan display, this means the service life of the activated charcoal filter has expired (with recirculation only) and the stainless steel grease filter needs to be thoroughly cleaned:



- ▶ Press the selection button for the cooktop extractor.
- ▶ Press any button.
- $F$  is shown in the fan display.

### Changing the filter

- ▶ Switch off the cooktop with integrated cooktop extractor.
- ▶ Observe all warnings that are described in the Cleaning chapter.
- ▶ Replace the activated charcoal filter.
- ▶ Clean the stainless steel grease filter, the air inlet nozzle, the air guiding housing and the housing base.

### Resetting the filter service display

If the activated charcoal filter has been replaced (with recirculation only) and the stainless steel grease filter has been cleaned, it will be necessary to reset the filter service display.

- ▶ Switch on the cooktop with integrated cooktop extractor.
- The fan display will show a flashing  $F$ .
- ▶ Press the selection button on the cooktop extractor for at least 4 seconds until a flashing  appears. After a few seconds, a solid  will be displayed.
- The filter service display has been reset.

## 7.5 Saving energy

- ▶ Follow all of the energy-saving tips to use the cooktop with integrated cooktop extractor in an energy-efficient manner.
- ▶ When purchasing cookware, pay attention to the diameter of the base as the upper diameter of the pot is usually specified. The diameter of the base is often smaller.
- ▶ Use pressure cookers. Due to the closed cooking chamber and the overpressure, these save a great deal of time and energy. The short cooking time also helps preserve vitamins.
- ▶ Make sure there is sufficient liquid in the pressure cooker. An empty pot which is still being heated can lead to overheating. This can damage both the cooking zone and the pot.
- ▶ If possible, always seal cookware using a suitable lid.
- ▶ Choose a suitable size of cookware for the amount of food you are cooking. A big pot that is barely filled requires a lot of energy.

## 8 Cleaning and maintenance

- ▶ Observe all safety and warning information (see Safety chapter).
- ▶ Follow the enclosed manufacturer's information.
- ▶ Make sure that the cooktop and cooktop extractor have been switched off completely and have cooled down prior to the planned cleaning and maintenance work to prevent injury (see the Operation chapter).
- Regular cleaning ensures the longevity of the product and optimal functioning.
- ▶ Adhere to the following cleaning and maintenance cycles:

Component	Cleaning cycle
Operating panel	Immediately after every soiling
Cooktop	Immediately after every soiling every week thoroughly with standard commercially available glass ceramic cleaners
Cooktop extractor	Weekly
Air inlet nozzle and stainless steel grease filter	After every time you prepare very greasy foods; at least weekly, when the fan level indicator = $F$ by hand or in the dishwashing machine (at a max. 65 °C); Only clean the stainless steel surfaces in the polishing direction!
Air guiding housing	Clean every 6 months or when replacing the activated charcoal filter
Activated charcoal filter (only for recirculated air)	Replace after the build-up of odour, when the extraction power has diminished or the fan level indicator shows $F$

Tab. 8.1 Cleaning cycles

### 8.1 Cleaning agents

**INFO** Due to the use of aggressive cleaning agents and abrasion caused by the pot bases the surface will become damaged and dark stains will occur.

You need a special glass ceramic panel scraper and suitable cleaning agents to clean the cooktop.

- ▶ Never use steam cleaners, abrasive sponges, scouring pads, or chemically aggressive cleaning agents (e.g. baking oven spray).
- ▶ Make sure that the cleaning agent does not contain any sand, soda, acids or chloride.

#### For air inlet nozzle and grease filter

- ▶ Do not use any aggressive, acidic or alkaline cleaning agents.

### 8.2 Maintaining the cooktop

- ▶ Do not use the cooktop as a worktop or shelf.
- ▶ Do not push or pull cookware across the cooktop.
- ▶ Always lift pots and pans.
- ▶ Keep the cooktop clean.
- ▶ Remove any kind of soiling immediately.
- ▶ Only use cookware which is suitable for glass ceramic panels (see the Device description chapter)

### 8.3 Cleaning the cooktop

**INFO** When the cooktop extractor is switched on, the air inlet nozzle is installed to ensure that no small and light objects, such as cleaning wipes made of fabrics or paper are sucked in.

- ▶ Make sure that the cooktop is switched off (see Operating chapter).
- ▶ Wait until all cooking zones are cold.
- ▶ Remove all coarse soiling and food residues from the cooktop with a glass ceramic scraper.
- ▶ Apply the cleaning agent onto the cold cooktop.
- ▶ Rub the cleaning agent with a paper towel or a clean cloth.
- ▶ Wipe off the cooktop while wet.
- ▶ Rub the cooktop dry with a clean cloth.

#### When the cooktop is hot:

- ▶ Immediately remove molten residues of plastic, aluminium film, sugar or foods containing sugar with a glass ceramic scraper from the hot cooking zone to prevent burning them in.

#### Special soiling

- ▶ Heavy soiling and stains (limescale stains, pearly shimmering stains) are best to be removed if the cooktop is still warm.
- ▶ Soften dried dirt residues using a damp cloth.
- ▶ Remove dirt residues with the glass ceramic scraper.
- ▶ Always remove grains, crumbs or the like which fall onto the cooktop during general cooking work right away to prevent the surface from being scratched.

Coloured changes and shiny surfaces are not cooktop damage. They do not impact on the function of the cooktop and the stability of the glass ceramic.

Discolourations to the cooktop arise from residues which are not removed and have been burnt in.

Glossy spots are caused by the abrasion of the pot base, especially when using cooking utensils with aluminium bases, or by unsuitable cleaning agents. They are very hard to remove.

## 8.4 Cleaning the cooktop extractor

The air inlet nozzle and the stainless steel grease filter absorb the greasy components of the kitchen vapour.

- ▶ Make sure that the cooktop and cooktop extractor are switched off (see Operating chapter).
- ▶ Wait until the fan display is 0.
- ▶ Clean the cooktop extractor in accordance with the cleaning cycles (see Tab. 7.1).
- ▶ Clean the surfaces of the exhaust air system using a soft damp cloth, detergent or a mild window cleaning agent.
- ▶ Soften dried-on dirt residues using a damp cloth (do not scratch!).

### 8.4.1 Removing the air inlet nozzle and stainless steel grease filter

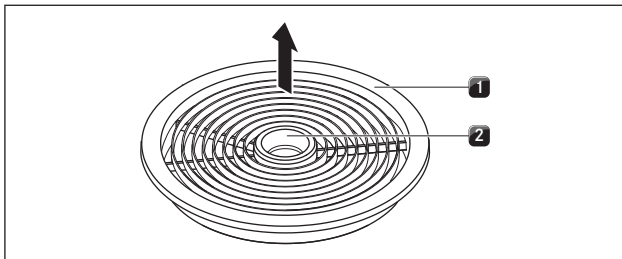

Fig. 8.1 Removing the air inlet nozzle

- [1] Air inlet nozzle
- [2] Access opening

**Prerequisite:** The fan level indicator indicates 0.

- ▶ Reach into the access opening [2] with your hand.
- ▶ Remove the air inlet nozzle [1] out upwards.

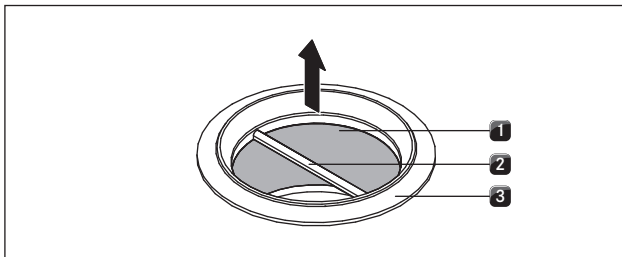

Fig. 8.2 Removing the stainless steel grease filter

- [1] Stainless steel grease filter
- [2] Handle
- [3] Suction opening

- ▶ Grab the stainless steel grease filter using the handle [2].
- ▶ Pull the stainless steel grease filter [1] out of the suction opening [3] upwards.

### 8.4.2 Cleaning the air inlet nozzle and stainless steel grease filter

**INFO** Clean the stainless steel surfaces in the polishing direction only.

**INFO** If the stainless steel grease filter can no longer be cleaned completely, this means the stainless steel grease filter will need to be replaced.

#### Manual cleaning

- ▶ Use a degreasing cleaning agent.
- ▶ Rinse the inlet nozzle and stainless steel grease filter with hot water.
- ▶ Use a soft brush to clean the inlet nozzle and stainless steel grease filter.
- ▶ After cleaning, rinse the inlet nozzle and stainless steel grease filter well.

#### Cleaning in the dishwasher

- ▶ Rinse the air inlet nozzle and the stainless steel grease filter with a rinsing program at a maximum of 65 °C.

### 8.4.3 Installing stainless steel grease filter and air inlet nozzle

- ▶ Grab the stainless steel grease filter using the handle [2] (Fig. 7.2)
- ▶ Insert the stainless steel grease filter [1] into the suction opening.
- ▶ Make sure that the stainless steel grease filter rests against the bottom housing base. A lock is not needed and is not provided.
- ▶ Reach into the access opening [2] of the inlet nozzle with your hand (Fig. 7.1).
- ▶ Insert the air inlet nozzle (Fig. 7.1; [1]) centrally into the suction opening.
- ▶ Press the air inlet nozzle upwards until it engages.

## 8.5 Cleaning the air guiding housing

Greasy deposits and limescale residues from the cooking vapour can accumulate on the surface of the air guiding housing. Regular, thorough cleaning (see Table 7.1) is thus necessary.

The air guiding housing is on the underside of the cooktop in the floor unit.

### 8.5.1 Opening the air guiding housing

- ▶ Make sure that the cooktop and cooktop extractor are switched off (see Operating chapter).
- ▶ Wait until the fan display is 0.

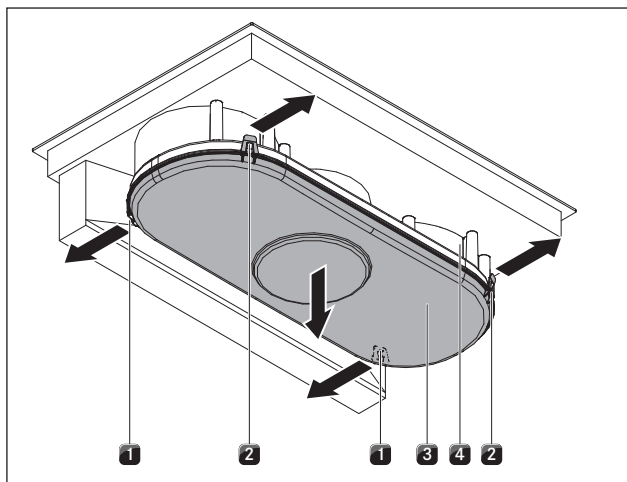

Fig. 8.3 Opening the air guiding housing

- [1] Rear locks
- [2] Front locks
- [3] Housing base
- [4] Air guiding housing

- ▶ Hold the housing base with one hand [3].
- ▶ Open both locks on the rear [1].
- ▶ Open both front locks [2].
- ▶ Remove the housing base [3].
- ▶ Clean the air guiding housing [4] and the housing base [3] with a mild cleaning agent.

### 8.5.2 Closing the air guiding housing

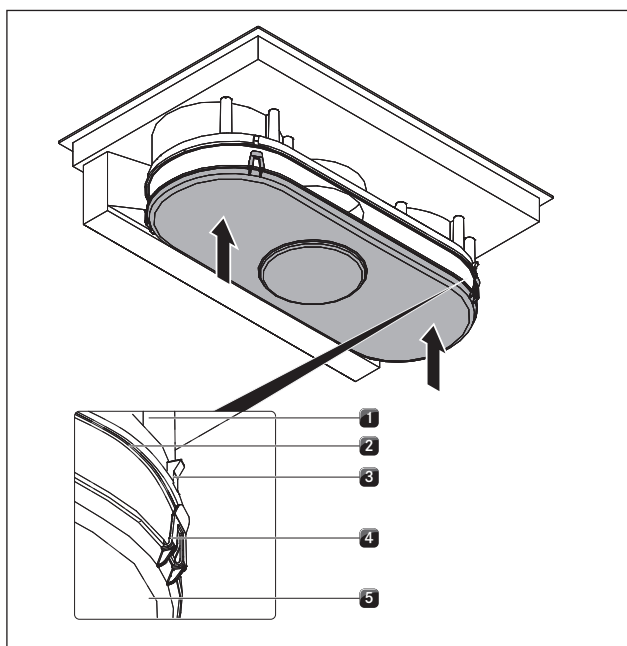

Fig. 8.4 Closing the air guiding housing

- [1] Air guiding housing
- [2] Sealing groove
- [3] Hooks
- [4] Locking stop
- [5] Housing base

- ▶ Using both hands, position the housing base [5] so that the position of the locking straps [4] on the housing base match the position of the hooks [3] on the housing.
- ▶ Insert the housing base at the sealing groove [2] of the air guiding housing [1].
- ▶ Press the housing base [5] upwards until the 4 locks (2 front, 2 rear) engage into the hooks [3].
- ▶ Check that all 4 locking straps [4] have correctly engaged.

## 8.6 Replacing the activated charcoal filter

Two activated charcoal filters are used only when the cooktop extractor is being operated in recirculated air mode. The activated charcoal filter binds odorous materials which arise during cooking.

**INFO** The activated charcoal filters must be replaced when the fan level indicator indicates  $F$  (filter service display). BAKF activated charcoal filters can be purchased from your specialist. You can also contact BORA on its homepage <http://www.bora.com>.

- ▶ Make sure that the cooktop and cooktop extractor are switched off (see Chapter 6.1).
- ▶ Wait until the fan display is  $\square$ .

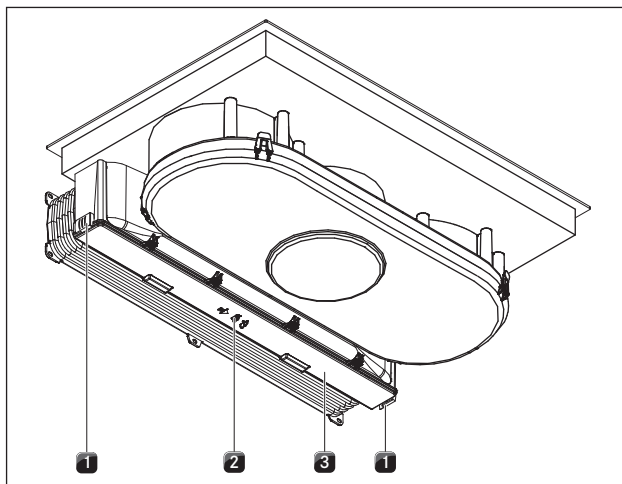

Fig. 8.5 Releasing the activated carbon filter housing lid

- [1] Outer locks
- [2] Middle lock
- [3] Activated carbon filter housing cover



### Removing the activated carbon filter

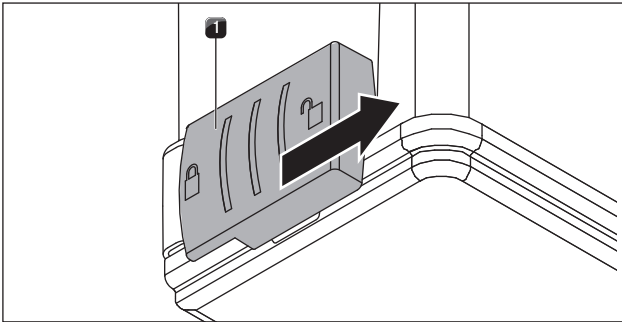

Fig. 8.6 Opening the outer locks

[1] Outer lock

- ▶ Open the two outer locks [1].

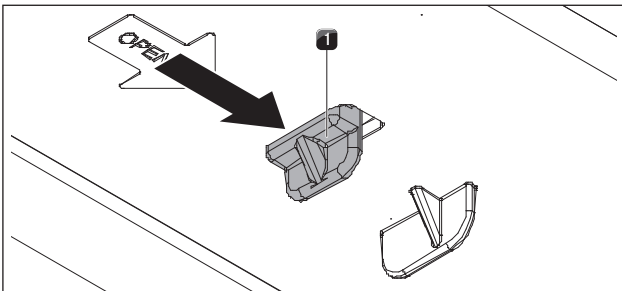

Fig. 8.7 Opening the middle locks

[1] Middle lock

- ▶ Open the middle lock [1].
- ▶ Fold down the housing cover until it engages.

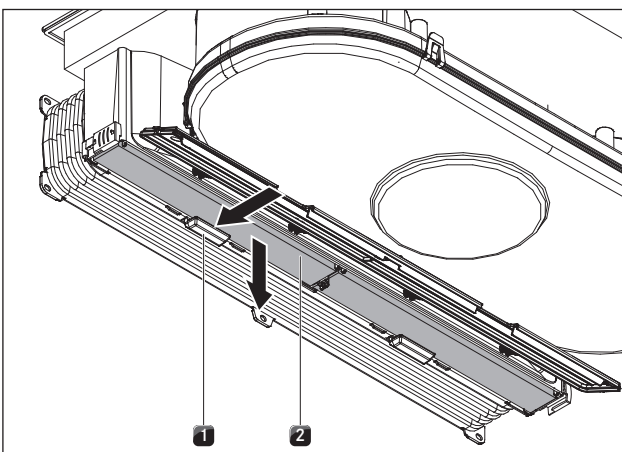

Fig. 8.8 Removing the activated charcoal filter

[1] Filter retainer  
[2] Activated charcoal filter

- ▶ Hold the activated charcoal filter with one hand [2].
- ▶ Push the filter retainer [1] backwards.
- ▶ Pull the activated charcoal filter down and out.
- ▶ Dispose of the used activated charcoal filter in household waste.

### Inserting the activated charcoal filter

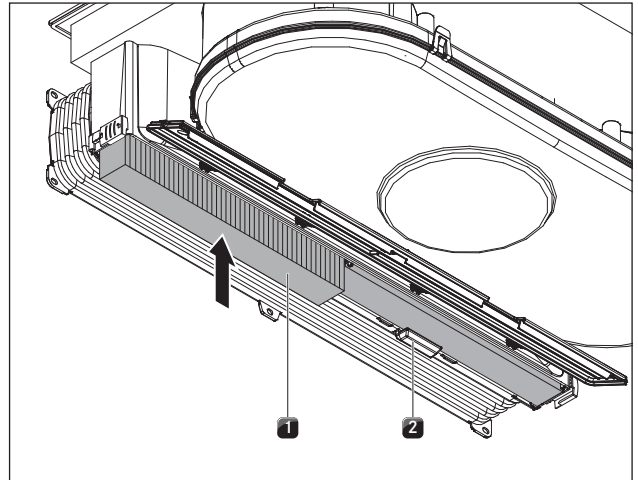

Fig. 8.9 Inserting the activated charcoal filter

[1] Activated charcoal filter  
[2] Filter retainer

- ▶ Position the new activated charcoal filter [1] so that the arrow points to the rear and is visible from below.
- ▶ Slide the activated charcoal filter into the housing.
- ▶ Push the activated charcoal filter upwards until the filter retainer [2] engages.

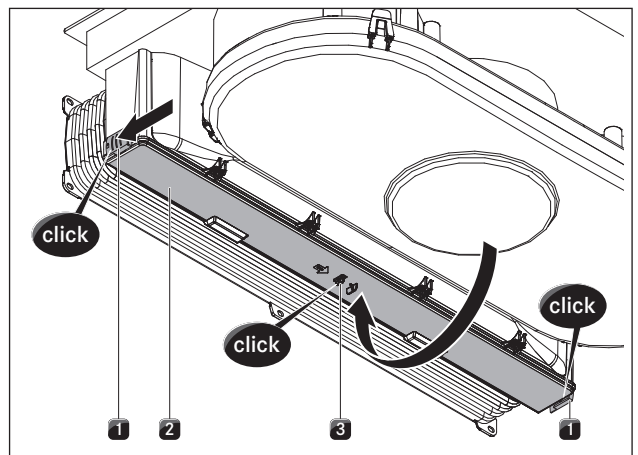

Fig. 8.10 Closing the activated charcoal filter housing cover

[1] Outer locks  
[2] Activated charcoal filter housing cover  
[3] Middle lock

- ▶ Fold up the activated charcoal filter housing cover [2].
- ▶ Press the activated charcoal filter housing cover in the centre until the middle lock [3] engages.
- ▶ Press the activated charcoal filter housing cover on the sides and close the outer locks [1] until they engage.

### Resetting the filter service display

- ▶ Reset the filter service display (see the Operation section).

## 9 Troubleshooting

Operating situation	Cause	Remedy
The cooktop or the fan cannot be switched on.	The fuse or the automatic circuit breaker of the electrical installation of the apartment and/or house is defective.	Replace the fuse. Switch the automatic circuit breaker back on.
	The fuse or the automatic circuit breaker trips several times.	Call the BORA Service Team.
	The power supply is disconnected.	Have a specialist electrician inspect the power supply.
Odours and vapours arise when the new cooktop is put into operation.	This is normal on brand-new appliances.	Wait a few operating hours. Contact the Service Team if the odour persists.
$\underline{L}$ is displayed in the cooking zone indicator.	No or unsuitable cookware has been placed on the cooking zone.	Only use suitable cookware. Select the cookware size depending on the cooking zone (see the Device Description chapter).
$\perp$ is displayed in the cooking zone indicator.	The childproofing feature is activated.	Switch off the childproofing feature (see the Operation chapter).
A cooking zone or the entire cooktop switches off automatically.	The operating time of a cooking zone has been exceeded.	Put the cooking zone back into operation (see the Operation chapter).
	The overheating protection has tripped.	(see the Device Description chapter)
The power setting is automatically shut off prematurely.	The overheating protection has tripped.	(see the Device Description chapter)
$E\text{-}03$ is shown across all 4 cooking zone indicators and the cooktop switches off during operation.	One or more sensor buttons are covered, e.g. due to finger contact or by objects placed on them.	Clean the operating panel or remove objects (see the Device description chapter).
The cooling fan continues running after the cooktop has been switched off.	The cooling fan will continue to run until the cooktop has cooled down and will then switch off automatically.	Wait until the cooling fan switches off automatically.
$E$ is displayed in the cooking zone indicator.	An error has occurred in the electronic system.	Interrupt the cooktop power supply for approx. 1 minute. If the problem continues to persist after the power supply has been restored, write down the error number and contact the BORA Service Team.
$F$ is displayed in the fan level indicator.	The period of use of the filters has been exceeded.	Replace the activated charcoal filter (with recirculation only) and thoroughly clean the stainless steel grease filter. In case of heavy soiling, replacing the stainless steel grease filter is also recommended (see Cleaning and maintenance chapter).
The extraction performance of the cooktop extractor has decreased.	The stainless steel grease filter is heavily soiled.	Clean or replace the stainless steel grease filter.
	The activated charcoal filter is heavily soiled (BFU only).	Replace the activated charcoal filter.
	There is an object in the air guiding housing (e.g. cleaning cloth).	Remove the trapped object.
$E\text{-}B1$ or $E\text{-}B2$ is shown in the fan level indicator.	The fan is defective or a duct connection has become loose.	Call the BORA Service Team.
$E$ is displayed in the fan level indicator. The fan cannot be switched on.	The Home-In contact is broken.	When using a window contact switch (safety device), the window must be open when the fan is operating.
	The safety device is defective.	Call the BORA Service Team.

Tab. 9.1 Resolving a fault

► In all other instances, call the BORA Service Team (see the Warranty, service and spare parts chapter).

## 10 Decommissioning, disassembly and disposal

- ▶ Observe all safety and warning information (see the Safety section).
- ▶ Follow the enclosed manufacturer's information.

### 10.1 Decommissioning

Decommissioning is understood as final shutdown and disassembly. Following decommissioning, the device can either be installed into other units, sold on privately or disposed of.

---

**INFO** Electricity and gas connections may only be disconnected by qualified specialists.

---

- ▶ To decommission, switch the device off (see Operation section)
- ▶ Disconnect the device from the power supply.

### 10.2 Disassembly

For removal, the device must be accessible for disassembly and disconnected from the power supply.

- ▶ Undo the mounting brackets.
- ▶ Remove the silicone joints.
- ▶ Disconnect the device from the extractor duct.
- ▶ Remove the device from the worktop by lifting it upwards.
- ▶ Remove any other accessories.
- ▶ Dispose of the old device and any contaminated accessories as described under "Environmentally-friendly disposal".

### 10.3 Environmentally-friendly disposal

#### Disposal of transport packaging

---

**INFO** The packaging protects the device from damage in transport. The packaging materials have been selected from environmental and disposal perspectives and are therefore recyclable.

---

Returning the packaging to the materials cycle saves resources and reduces waste volumes. Your specialist supplier will take the packaging back.

- ▶ Give the packaging to your specialist supplier or
- ▶ Dispose of the packaging properly in line with local regulations.

#### Disposal of old appliance



Electrical devices marked with this label may not be disposed of in domestic waste at the end of their service life. They must be disposed of at a collection point for the recycling of old electrical or electronic devices. You can find information from your city or district council.

Many electrical and electronic devices still contain valuable materials. But they also contain damaging materials which were necessary for them to function properly and safely. These can damage human health or the environment if disposed of improperly or incorrectly handled.

- ▶ Never put your old appliance in domestic waste.
- ▶ Take the old appliance to a regional collection point for return and recycling electrical and electronic components and other materials.

# 11 Warranty, technical service, spare parts, accessories

- Observe all safety and warning information (see the Safety chapter).

## 11.1 BORA manufacturer's warranty

BORA provides its end customers with a 2-year manufacturer's warranty for its products. The end customer is entitled to this warranty in addition to the statutory claims for defects against the sellers of our products.

The manufacturer's warranty applies to all BORA products sold by authorised BORA dealers with the European Union, with the exception of products labelled by BORA as Universal products or accessories.

The manufacturer's warranty starts as soon as the BORA product is handed over to the end customer by an authorised BORA dealer and is valid for 2 years. By registering on [www.bora.com/registration](http://www.bora.com/registration) the end customer has the possibility of extending the manufacturer's warranty.

The manufacturer's warranty requires expert (in accordance with the valid BORA ventilation handbook and operating instructions at the time of installation) installation of the BORA products by an authorised BORA dealer. During use, the end customer is to adhere to the specifications and instructions in the operating manual. In order to file a warranty claim, the end customer is to notify their dealer or BORA of the fault and must present the receipt. Alternatively, the end customer can provide proof of purchase by registering on [www.bora.com](http://www.bora.com). BORA guarantees that all BORA products are free from material and product defects. The defect must exist prior to delivery of the product to the end customer. In the event that a warranty claim is filed, the warranty shall not commence anew.

BORA will correct defects in BORA products at its own discretion by repairing or replacing the product. All costs for the correction of defects under the manufacturer's warranty shall be assumed by BORA.

Expressly not covered by the BORA manufacturer's warranty are:

- BORA products that were not sold by authorised BORA dealers
- Damage caused by non-adherence to the operating instructions (including product care and cleaning) This represents improper use.
- Damage caused by normal use, e.g. traces of usage on the cooktop

- Damage caused by external influences (such as transport damage, ingress of condensation, damage caused by the elements such as a lightning strike)
- Damage caused by repairs or attempts to repair not made by BORA or persons authorised by BORA
- Damage to the glass ceramic
- Voltage fluctuations
- Secondary damage or claims for damages beyond the defect
- Damage to plastic parts

Legal claims, particularly statutory claims for defects or product liability are not limited by the warranty.

If a defect is not covered by the manufacturer's warranty, the end customer can employ the services of the BORA technical service, however, they must cover the costs themselves.

The laws of the Federal Republic of Germany apply to these warranty conditions.

You can contact us by:

- Telephone: +49 800 7890 0987 Monday to Thursday from 08:00-18:00 and Friday from 08:00-17:00
- Email: [info@bora.com](mailto:info@bora.com)

### 11.1.1 Warranty extension

You can extend the guarantee by registering at [www.bora.com/registration](http://www.bora.com/registration).

## 11.2 Service

### BORA Service:

see reverse side of operating and assembly instructions



- In the case of faults you cannot fix yourself, contact your BORA specialist supplier or the BORA Service Team.

The BORA Service Team will require the type designation and serial number of your device (FD number).

Both values are indicated on the rate plate in the warranty insert and the underside of the device.

## 11.3 Spare parts

- Only use original spare parts for repairs.
- Repairs may only be carried out by the BORA Service Team.

---

**INFO** Spare parts can be obtained from your BORA dealer, the BORA online service website at [www.bora.com/service](http://www.bora.com/service) or by calling the service number provided.

---

## 11.4 Accessories

- BFF stainless steel grease filter
- Air inlet nozzle BFIED
- All Black air inlet nozzle BEDAB
- Sealing tape UDB25
- Cooktop frame BKR830

### Special accessory BFIA:

- Recirculation conversion set BUSU
- Exhaust air duct extension BLAVH1

### Special accessory BFIU:

- Exhaust air conversion set BUSAE
- Activated charcoal filter set with ion exchanger BAKFS  
(2 pcs)

## 12 Notes:



**Germany:**

**BORA Lüftungstechnik GmbH**  
Rosenheimer Str. 33  
83064 Raubling  
Germany  
T +49 (0) 8035 / 9840-0  
F +49 (0) 8035 / 9840-300  
info@bora.com  
www.bora.com

**Austria:**

**BORA Vertriebs GmbH & Co KG**  
Innstraße 1  
6342 Niederndorf  
Austria  
T +43 (0) 5373 / 62250-0  
F +43 (0) 5373 / 62250-90  
mail@bora.com  
www.bora.com

**Europe:**

**BORA Holding GmbH**  
Innstraße 1  
6342 Niederndorf  
Austria  
T +43 (0) 5373 / 62250-0  
F +43 (0) 5373 / 62250-90  
mail@bora.com  
www.bora.com

**Australia - New Zealand:**

**BORA APAC Pty Ltd**  
100 Victoria Road  
Drummoyne NSW 2047  
Australia  
T +61 2 9719 2350  
F +61 2 8076 3514  
info@boraapac.com.au  
www.bora-australia.com.au

