

EN **Installation instructions**
PKA3/PKA3AB, PKAS3/PKAS3AB

BORA Pro cooktop extractor

BORA Pro cooktop extractor All Black

BORA Pro cooktop extractor system with integrated fan

BORA Pro cooktop extractor system with integrated fan All Black

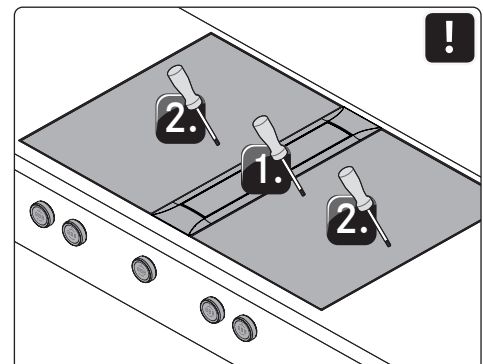
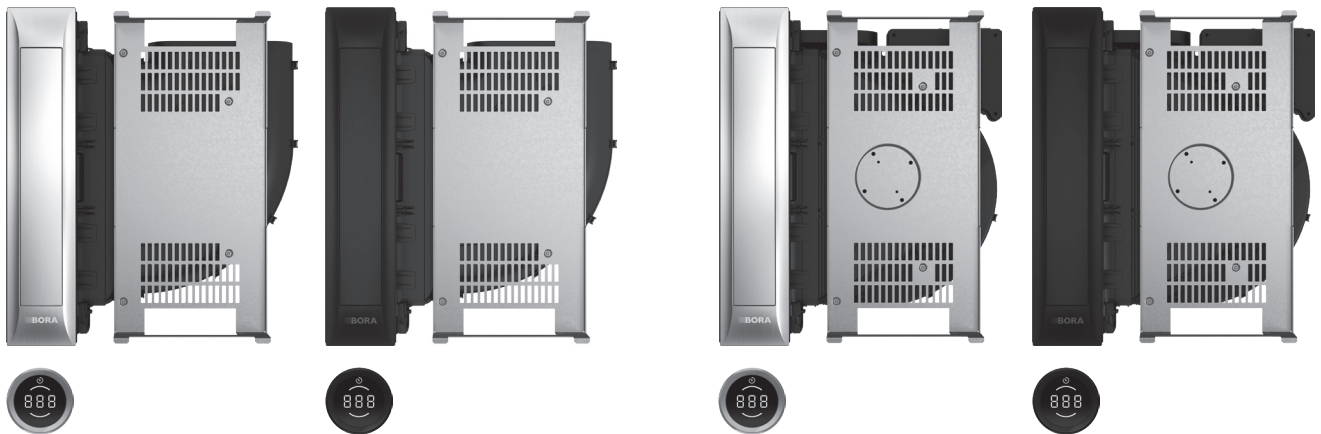

PKA3XIMEN-101

Table of Contents

1	General information	3	4.10	Connecting external switch contacts	19
1.1	Liability	3	4.10.1	Preparing PKAS3/PKAS3AB	19
1.2	Validity of the operating and installation instructions	3	4.10.2	Preparing the control unit on PKA3/PKA3AB	19
1.3	Product conformity	3	4.10.3	Preparing connection cables for external switching equipment	20
1.4	Data protection	3	4.10.4	Installing the external switch device	20
1.5	Presentation of information	3	4.11	Establishing communication and power connection	22
2	Safety	4	4.11.1	Connecting the control knobs	22
2.1	Use as intended	4	4.11.2	Ports on cooktop extractor system PKAS3/PKAS3AB	22
2.2	General safety instructions	4	4.11.3	Connecting cooktop extractor PKA3/PKA3AB	22
2.3	Safety instructions for installation	5	4.11.4	Establishing contact between the cooktop extractor and cooktops	23
2.4	Safety instructions – repairs, servicing and spare parts	6	4.11.5	Connecting the power supply	23
2.5	Safety instructions – disassembly and disposal	6	4.12	Basic configuration	24
3	Technical data	7	4.13	Initial operation	25
3.1	BORA Pro cooktop extractor PKA3/PKA3AB	7	4.14	Function test	25
3.2	BORA Pro cooktop extractor system with integrated fan PKAS3/PKAS3AB	7	4.15	Sealing the appliances	25
3.3	BORA Professional 3.0 control knob dimensions	8	4.16	Handover to user	25
4	Installation	9	5	Decommissioning, disassembly and disposal	26
4.1	General installation instructions	9	5.1	Decommissioning	26
4.1.1	Operating the cooktop extractor with a fireplace that depends on the air in the room	9	5.2	Disassembly	26
4.2	Checking the scope of delivery	9	5.3	Environmentally-friendly disposal	26
4.3	Tools and aids	10	6	Notes	27
4.4	Assembly instructions	10			
4.4.1	Safety clearances	10			
4.4.2	Minimum installation dimensions (standard set-up)	10			
4.4.3	Worktop and kitchen units	11			
4.4.4	Recirculation when using the cooktop extractor as a recirculation system	11			
4.5	Cut-out dimensions	11			
4.5.1	Flush installation	11			
4.5.2	Surface mounting	12			
4.6	Installing the control knob in the floor unit front panel	12			
4.6.1	Cooktop extractor bore holes	12			
4.6.2	Example bore holes	13			
4.6.3	Fitting the control knob	13			
4.7	Planning variations for PKA3/PKA3AB	14			
4.7.1	Airflow straight to the side	14			
4.7.2	Airflow to the left (installation rotated by 180°)	15			
4.7.3	Rotating the cover frame by 180°	15			
4.8	Installing the cooktop extractor	15			
4.8.1	Fitting the cooktop extractor	16			
4.8.2	Securing the cooktop extractor	16			
4.9	Installing the duct system	17			
4.9.1	Duct connection dimensions	17			
4.9.2	Preparing for installation	18			
4.9.3	Connecting the duct system to the appliance	18			
4.9.4	Standard set-up for PKA3/PKA3AB	18			
4.9.5	Installing the additional fan	19			

1 General information

These instructions contain important information to protect you from injury and prevent damage to the appliance.

Please read these instructions carefully before installing or using the appliance for the first time.

Other documents apply alongside these instructions.

Please by all means adhere to all documents that form part of the scope of delivery.

Assembly, installation and commissioning must always occur in line with national laws, regulations and standards. The work must be performed by qualified specialists who are familiar with and comply with the supplementary regulations of the local utility companies.

All safety and warning information as well as the handling instructions in the accompanying documents must be observed.

1.1 Liability

BORA Holding GmbH, BORA Vertriebs GmbH & Co KG, BORA APAC Pty Ltd and BORA Lüftungstechnik GmbH – hereinafter referred to as BORA – does not assume any liability for damage arising from disregard for or non-adherence to the documents included in the scope of delivery!

Furthermore, BORA shall not be held liable for damage caused by improper installation or failure to observe the safety and warning instructions!

1.2 Validity of the operating and installation instructions

These instructions apply to several appliance versions. It is therefore possible that some of the features described do not apply to your appliance. The details of the figures contained herein may differ from some appliance versions and are to be understood as schematic diagrams.

1.3 Product conformity

Directives

The appliances meet the following EU/EC directives:

2014/30/EU EMC Directive

2014/35/EU Low Voltage Directive

2009/125/EC Ecodesign Directive

2011/65/EU RoHS Directive

1.4 Data protection

During operation your cooktop extractor saves pseudonymised data such as menu settings entered by you, operating hours of the individual technical units and the number of functions selected. Furthermore, your cooktop extractor documents errors in combination with the number of operating hours.

Data can only be read out manually via your cooktop extractor. This decision is therefore your responsibility.

These saved data then enable a rapid error search and troubleshooting in the event of servicing.

1.5 Presentation of information

We use standard formatting, numbering, symbols, safety instructions, terms and abbreviations so that you can work quickly and safely when using this manual.

The term “appliance” is used to refer to cooktops, cooktop extractors or cooktops with integrated cooktop extractor.

Instructions are indicated with an arrow.

► Always follow all instructions in the prescribed order.

Enumerations are indicated with a bullet point at the start of the line:

● Enumeration 1

● Enumeration 2



Information notes point to special features that must be taken into account.

Safety and warning instructions

The safety and warning instructions in this manual are emphasised with symbols and signal words.

Safety and warning instructions are structured as follows:

WARNING SYMBOL AND SIGNAL WORD!	
Type and source of danger	Results of non-compliance
► Measures to minimise risk	

Please note:

- warning symbols draw attention to a high risk of injury.
- The signal word indicates the severity of that risk.

Warning symbol	Signal word	Risk
	Danger	Indicates an immediate, hazardous situation which causes death or serious injury if not respected.
	Warning	Indicates a potentially hazardous situation which can cause death or serious injury if not respected.
	Caution	Indicates a potentially hazardous situation which can cause minor injury or damage to property if not respected.

Tab. 1.1 Meaning of the warning symbols and signal words

2 Safety

The appliance complies with the stipulated safety requirements. The user is responsible for the safe use of the appliance, cleaning and maintenance. Improper use can lead to personal injury and damage to property.

2.1 Use as intended

The appliance is solely intended for preparing food in private households.

This appliance is not intended for:

- outdoor use
- heating rooms
- cooling, ventilating or dehumidifying rooms
- use in mobile installation sites such as motor vehicles, ships or aeroplanes
- use with an external timer or a separate remote control system (except for emergency shutdown)
- use at altitudes of over 2,000 m (metres above sea level)

Any other use or any use that goes beyond that which is described here is classed as unintended.

- i** BORA does not assume any liability for damages caused by improper use or incorrect operation.

All misuse is prohibited!

2.2 General safety instructions

⚠ DANGER!

Packaging components are a choking hazard

Packaging components (e.g. film, polystyrene) can be life-threatening for children.

- ▶ Store all packaging components out of reach of children.
- ▶ Dispose of the packaging properly and immediately.

⚠ DANGER!

Risk of electric shock or injury from damaged surfaces

The underlying electronics can be exposed or damaged due to fissures, fractures or cracks in appliance surfaces (e.g. damaged glass), particularly in the vicinity of the operating unit. This can cause an electric shock. Furthermore, a damaged surface can cause injuries.

- ▶ Do not touch the damaged surface.
- ▶ If there are any cracks, fissures or fractures, switch the appliance off immediately.
- ▶ Safely disconnect the appliance from the mains using the LS switch, fuses, automatic circuit breakers or contactor.
- ▶ Contact BORA Service.

⚠ WARNING!

Risk of injury from damaged components

Damaged components that cannot be removed without tools can cause injuries.

- ▶ Try not to repair or replace damaged components yourself.
- ▶ Contact BORA Service.

⚠ WARNING!

Risk of injury or damage due to incorrect components or unauthorised modifications

Incorrect components can lead to personal injury or damage to the appliance. Modifications, additions or alterations to the appliance can lead to safety risks.

- ▶ Only use original components.
- ▶ Do not make any modifications, additions or alterations to the appliance.

CAUTION!

Appliance components can cause injury if dropped

Appliance components (e.g. pan supports, operating controls, covers, grease filters, etc.) can cause injury if dropped.

- ▶ Place any appliance components that have been removed in a safe place near the appliances.
- ▶ Ensure that no components removed from the appliances can fall on the floor.

CAUTION!**Risk of injury from heavy lifting**

If not handled correctly, carrying and installing appliances can cause injury to the limbs or torso.

- ▶ If necessary, carry and install the appliance with another person.
- ▶ Use appropriate aids to prevent damage or injury.

CAUTION!**Damage from improper use**

The appliance surfaces must not be used as work or storage surfaces. This can damage the appliances (particularly in the case of hard and sharp objects). Never use the appliances as work or storage surfaces.

- ▶ Keep hard or sharp objects away from the appliance surfaces.

Faults and errors

- ▶ In the case of faults and errors, follow the instructions in the “Troubleshooting” chapter.
- ▶ In the event of any faults or errors that are not mentioned, switch the appliance off and contact BORA Service.

Pets

- ▶ Keep pets away from the appliance.

2.3 Safety instructions for installation

- i** The appliance must only be installed and assembled by trained specialists who are familiar with and comply with the standard national regulations and supplementary regulations of the local utility companies.
- i** During installation maintain the minimum clearance stated in the “Installation” (“Safety clearances”) chapter.
- i** Work on electrical components must only be conducted by trained electrical personnel.
- i** The appliance may only be installed with the power disconnected.

The electrical safety of the appliance is only guaranteed if it is connected to a protective

conductor system that has been installed in line with regulations. Ensure that this basic safety precaution is met.

The appliance must be suitable for the regional voltage and frequency.

- ▶ Check the information on the identification plate and in the event of deviations, do not connect the appliance.
- ▶ Conduct all work extremely attentively and conscientiously.
- ▶ Do not connect the appliance to the mains until the duct system has been installed or the recirculation filter has been fitted.
- ▶ Only use the connection cables supplied. Where necessary these are included in the scope of delivery.
- ▶ Do not use the appliance until installation is complete. This is the only way to ensure safe operation.

⚡ DANGER!**Risk of electric shock from damaged appliance**

A damaged appliance can cause an electric shock.

- ▶ Check the appliance for visible damage prior to installation.
- ▶ Do not install or connect any damaged appliances.
- ▶ Do not operate any damaged appliances.

CAUTION!**Risk of burning from control knobs that are not positioned optimally.**

If the control knobs are not installed in a suitable place, during operation there is a risk of sustaining burns from the cooktop surface.

- ▶ Only install the control knobs in a suitable place, which is practical and safe.

2.3.1 Safety instructions – cooktop extractor installation**⚡ DANGER!****Risk of electric shock from residual charge**

Electrical components in the appliance can contain residual charge and cause an electric shock.

- ▶ Do not touch any exposed contacts.

⚡ DANGER!**Risk of electric shock from incorrect stripping of cables**

Incorrect stripping of the connection cable to external switching devices results in a risk of electric shock.

- ▶ Ensure that the connection cable is secured with the strain relief clamp within the control unit.
- ▶ Ensure that the stated stripping lengths are adhered to.

⚡ WARNING!**Risk of injury due to moving fan wheel**

There is a risk of injury while the fan is turning.

- ▶ Only install the device with the power disconnected.
- ▶ Connect both sides of the fan to the duct system before commissioning.

Special safety instructions for the planning of extractor systems**⚡ DANGER!****Risk of smoke inhalation**

When the cooktop extractor is used in exhaust air mode, it draws in air from the room it is installed in and from neighbouring rooms. If there is insufficient air supply, low pressure will occur. When used at the same time as a fireplace that is dependent on the air in the room, noxious gases can be sucked into the living areas from the chimney or outlet shaft.

- ▶ Make sure that there is always a sufficient air supply.
- ▶ Only use reliable, tried-and-tested switching devices, (e.g. window contact switch, low pressure warning device) and have them approved by a qualified expert (certified chimney sweep).

Ducting connected to wall sleeves

In the case of straight ducting and a distance < 900 mm between the fan and wall sleeve, a safety guard must be provided for (available as an accessory).

2.4 Safety instructions – repairs, servicing and spare parts

- i** The appliance must only be repaired and serviced by trained specialists who are familiar with and comply with the standard national regulations and supplementary regulations of the local utility companies.

- i** Work on electrical components must only be conducted by trained electrical personnel.

- ▶ Before any repair work, safely disconnect the appliance from the mains supply.

⚡ WARNING!**Risk of injury or damage from improper repairs**

Incorrect components can lead to personal injury or damage to the appliance. Modifications, additions or alterations to the appliance can lead to safety risks.

- ▶ Only use original spare parts for repairs.
- ▶ Do not make any modifications, additions or alterations to the appliance.

- i** A damaged power supply cable must be replaced by a suitable power supply cable. This may only be done by an authorised member of the After Sales Service team.

2.5 Safety instructions – disassembly and disposal

- i** The appliance must only be disassembled by trained specialists who are familiar with and comply with the standard national regulations and supplementary regulations of the local utility companies.

- i** Work on electrical components must only be conducted by trained electrical personnel.

- ▶ Before disassembly, safely disconnect the appliance from the mains supply.

⚡ DANGER!**Risk of electric shock from incorrect disconnection**

Incorrectly disconnecting the appliance from the mains results in a risk of electric shock.

- ▶ Safely disconnect the appliance from the mains using LS switches, fuses, automatic circuit breakers or contactors.
- ▶ Use an authorised measuring device to ensure that there is no power to the appliance.
- ▶ Do not touch exposed contacts on the electronic unit as they may contain residual charge.

3 Technical data

3.1 BORA Pro cooktop extractor PKA3/PKA3AB

Parameter	Value
Supply voltage	220–240 V
Frequency	50/60 Hz
Power consumption (including external BORA Universal article fans)	max. 550 W
Dimensions (width x depth x height)	482 x 540 x 176 mm
Control knob dimensions (diameter x depth)	Ø 49 mm 92 mm
Weight (incl. accessories/packaging)	9.25 kg
Cooktop extractor	
Power levels	1–9, P

Tab. 3.1 Technical data for PKA3/PKA3AB

PKA3/PKA3AB appliance dimensions

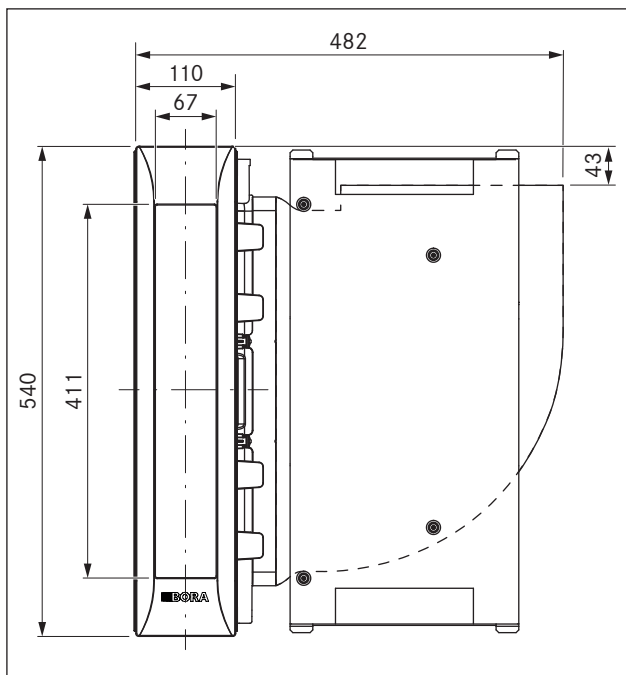

Fig. 3.1 PKA3/PKA3AB appliance dimensions from above

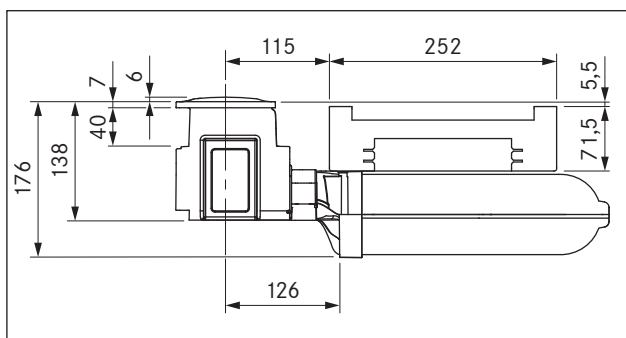

Fig. 3.2 PKA3/PKA3AB appliance dimensions front view

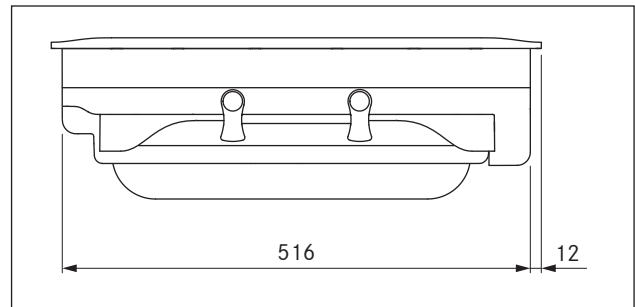

Fig. 3.3 PKA3/PKA3AB appliance dimensions side view

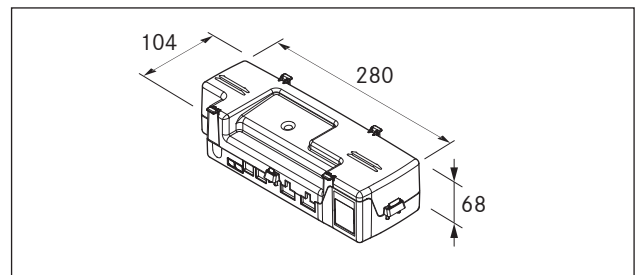

Fig. 3.4 Control unit dimensions

3.2 BORA Pro cooktop extractor system with integrated fan PKAS3/PKAS3AB

Parameter	Value
Supply voltage	220–240 V
Frequency	50/60 Hz
Power consumption (including external BORA Universal article fans)	max. 550 W
Internal motor power consumption	max. 165 W
Dimensions (width x depth x height)	468 x 540 x 199 mm
Control knob dimensions (diameter and depth)	Ø 49 mm 92 mm
Weight (incl. accessories/packaging)	12.5 kg
Cooktop extractor	
Power levels	1–9, P

Tab. 3.2 Technical data for PKAS3/PKAS3AB

PKAS3/PKAS3AB appliance dimensions

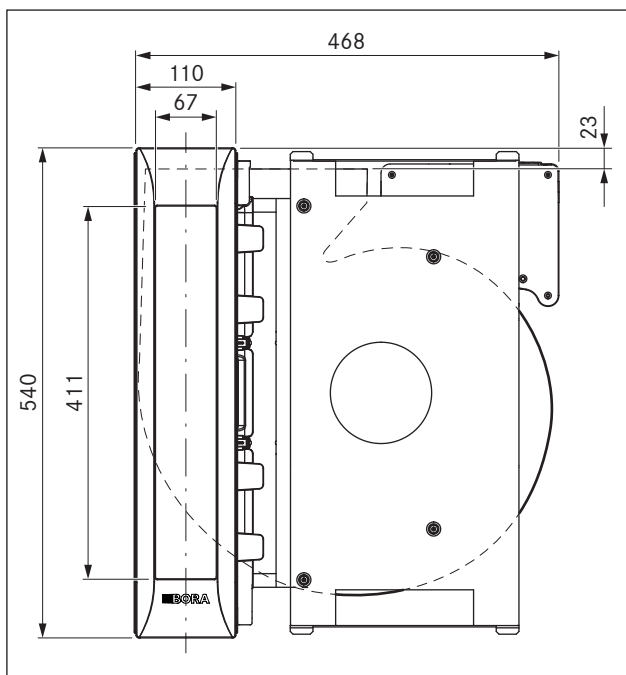

Fig. 3.5 PKAS3/PKAS3AB appliance dimensions from above

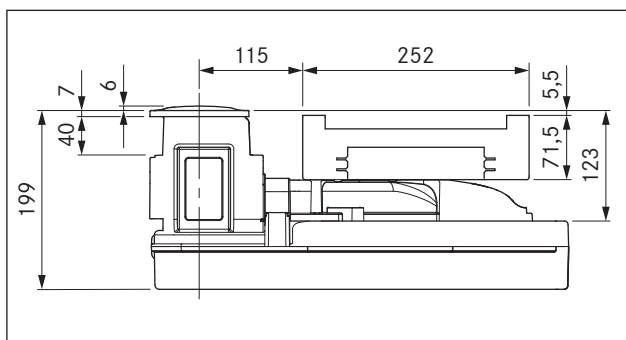

Fig. 3.6 PKAS3/PKAS3AB appliance dimensions front view

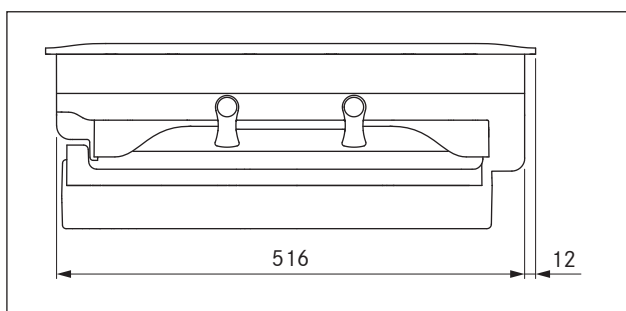

Fig. 3.7 PKAS3/PKAS3AB appliance dimensions side view

3.3 BORA Professional 3.0 control knob dimensions

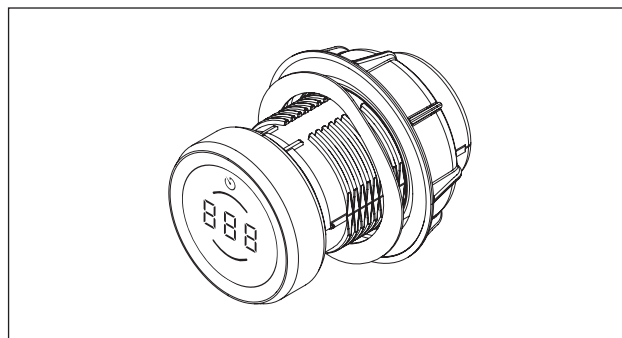

Fig. 3.8 Control knob

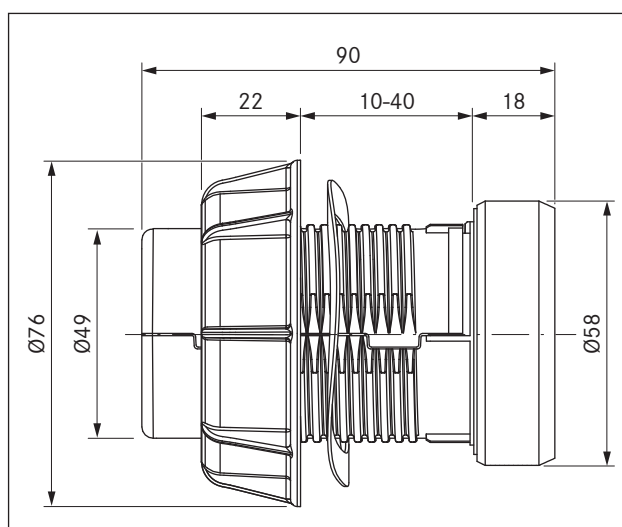

Fig. 3.9 Control knob dimensions

4 Installation

- ▶ Observe all safety and warning information (see „2 Safety“).
- ▶ Follow the enclosed manufacturer's information.

4.1 General installation instructions

- i** The appliances must not be installed above cooling devices, dishwashers, stoves, ovens, washing machines or dryers.
- i** The contact surfaces of the worktops and wall sealing strips must be made of a heat-resistant material (up to approx. 100°C).
- i** Worktop cut-outs must be moisture-sealed using suitable means and, where necessary, fitted with a thermal insulator.
- i** External devices may only be connected to the cooktop extractor connections provided.
- i** Extremely bright lights aimed directly at the appliances can cause colour variations in the appliances and are thus to be avoided.

4.1.1 Operating the cooktop extractor with a fireplace that depends on the air in the room

- i** National and regional laws and regulations must be observed with regard to the exhaust duct design.
- i** A sufficient air supply must be ensured.

Fireplaces that depend on the air in the room (e.g. gas, oil, wood or coal-fired heaters, continuous-flow water heaters, instantaneous water heaters) draw in air from the room in which they are installed and release the exhaust fumes into the outside air via an exhaust system (e.g. chimney).

If the cooktop extractor is used in exhaust air mode, it draws in air from the room in which it is installed as well as from neighbouring rooms. If there is insufficient air supply, low pressure will occur. Toxic gases could be drawn out of the chimney or extraction ducting and back into the room.

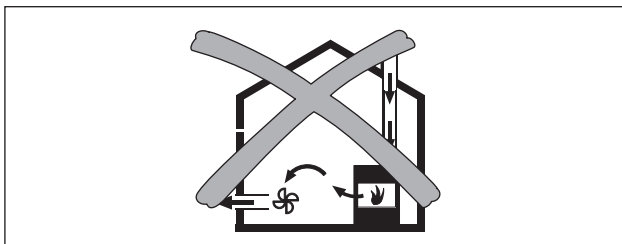

Fig. 4.1 Exhaust air installation – not permitted

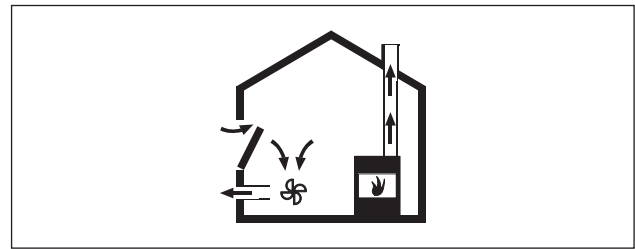

Fig. 4.2 Exhaust air installation – correct

- ▶ If simultaneously operating both a fireplace and the cooktop extractor in the same room, ensure that:
 - the maximum low pressure is 4 Pa (4 x 10⁻⁵ bar);
 - a safety device (e.g. window contact switch, low pressure warning device) is used to ensure that a sufficient supply of fresh air is guaranteed;
 - the exhaust air is not channelled into a chimney that is used for exhaust gases of appliances operated with gas or other combustibles;
 - the installation is checked and approved by an authorised certified engineer (e.g. heating engineer).
- i** No window contact switches may be installed that separate the control unit from the power supply (phase separation). Only the Home In interface is to be used.

4.2 Checking the scope of delivery

- ▶ Make sure the delivery is complete and check it for damage.
- ▶ If there are any missing or damaged parts, please notify the BORA After Sales Service.
- ▶ Do not under any circumstances install parts which are damaged.
- ▶ Dispose of transport packaging in the proper manner (see „5 Decommissioning, disassembly and disposal“).

Scope of delivery of PKA3/PKA3AB

Name	Quantity
Operating and installation instructions	1
Cooktop extractor	1
Height adjustment plate set	1
Installation clamps	4
Control knob	1
Stainless steel grease filter	1
Filter tray	1
Maintenance tray	1
Cover flap	1
CAT 5e communication cable	1
Control unit	1
Power supply cable	1
Straight duct piece	1
Control knob cable - extractor (1000 mm)	1
Shallow seal	1
Special scope of delivery only for PKA3AB	
BORA Pro knob ring All Black PKR3AB (to give the cooktops a more uniform appearance)	4

Tab. 4.1 Scope of delivery of PKA3/PKA3AB

Scope of delivery of PKAS3/PKAS3AB

Name	Quantity
Operating and installation instructions	1
Cooktop extractor	1
Height adjustment plate set	1
Installation clamps	4
Control knob	1
Stainless steel grease filter	1
Filter tray	1
Maintenance tray	1
Cover flap	1
Power supply cable	1
Control knob cable - extractor (250 mm)	1
Special scope of delivery only for PKAS3AB	
BORA Pro knob ring All Black PKR3AB (to give the cooktops a more uniform appearance)	4

Tab. 4.2 Scope of delivery of PKAS3/PKAS3AB

4.3 Tools and aids

The following tools are required to correctly install the appliance:

- pencil
- tape measure or folding metre stick
- standard or cordless drill with \varnothing 50 mm Forstner bit
- black, heat-resistant silicone sealant
- slotted screwdriver
- size 20 Torx screwdriver
- size 10 Torx screwdriver (PKA3/PKA3AB only)

4.4 Assembly instructions

4.4.1 Safety clearances

► Maintain the following safety clearances:

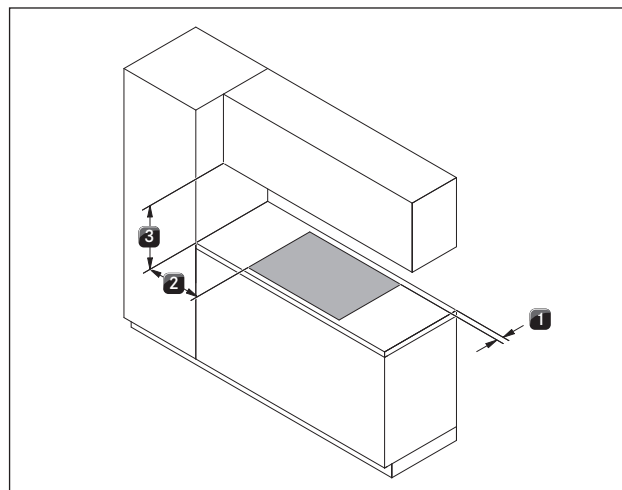

Fig. 4.3 Minimum distance

- [1] Minimum clearance of 50 mm at the back from the worktop cut-out to the rear edge of the worktop.
- [2] Minimum clearance of 300 mm from the left and right of the worktop cut-out to the adjacent cabinet or wall.
- [3] Minimum clearance of 600 mm between the worktop and the wall unit.

4.4.2 Minimum installation dimensions (standard set-up)

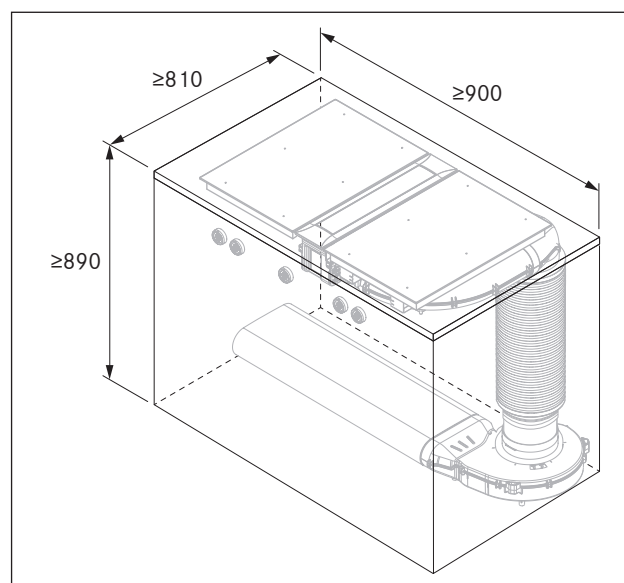

Fig. 4.4 Minimum installation dimensions for standard set-up of PKA3/PKA3AB

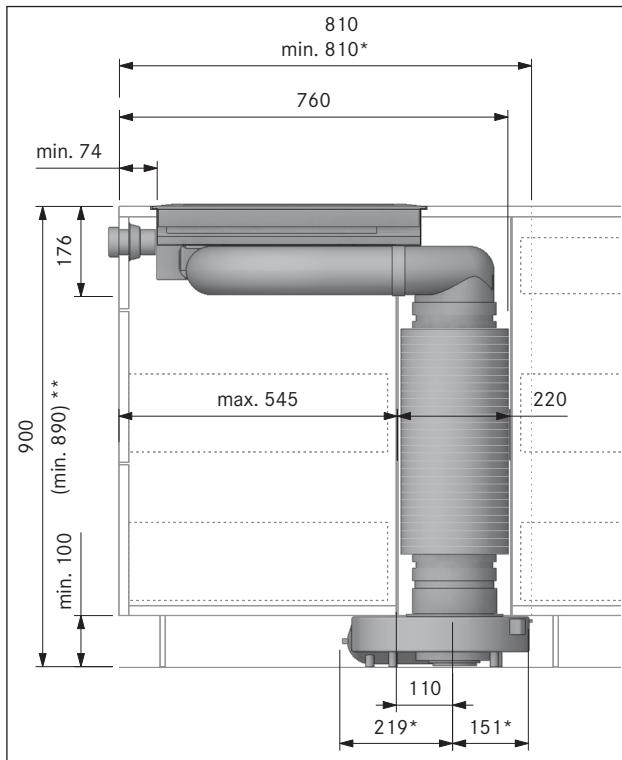

Fig. 4.5 Appliance installation dimensions for standard set-up of PKA3/PKA3AB with round silencer USDR50

4.4.3 Worktop and kitchen units

- ▶ Create the worktop cut-out taking into account the specified cut-out dimensions.
- ▶ Make sure that the cut surfaces of the worktops are properly sealed.
- ▶ Comply with the instructions of the worktop manufacturer.
- Cross bars on the kitchen unit in the area of the worktop cut-out may need to be removed.
- No false floor is necessary below the cooktop. If cable protection (false floor) is planned, the following must be taken into account:
 - it must be fitted in such a way that it can be removed for maintenance work;
 - to ensure sufficient cooktop ventilation, a minimum distance of 15 mm to the bottom edge of the cooktop is to be observed.
- The drawers and/or shelves in the floor unit must be removable.
- For correct installation, the drawers of the floor unit must be shortened depending on the installation situation.

4.4.4 Recirculation when using the cooktop extractor as a recirculation system

In the case of recirculation systems there must be a return flow aperture in the kitchen units:

- >500 cm² (per air cleaning box) in combination with cooktops PKFI3, PKI3, PKIW3, PKC3, PKCB3, PKCH3 and PKT3

- i** If several extractor systems are operated in recirculation mode, the return flow aperture for each air cleaning box must be calculated accordingly. Example: 2 recirculation systems = 2 x (>500 cm²)

For recirculation, the necessary return flow aperture can be created using a shortened plinth. A slatted plinth with at least the minimum opening cross-section can also be used.

- ▶ Ensure that the return flow aperture is large enough

4.5 Cut-out dimensions

- i** All dimensions are shown from the front edge of the front panel.

Worktop overhang

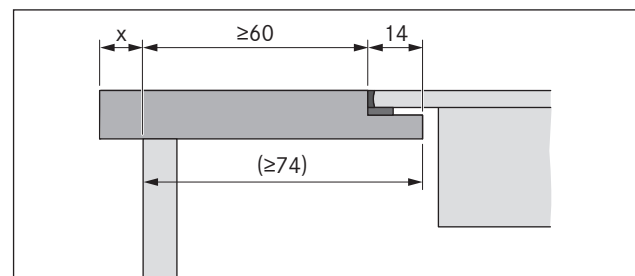

Fig. 4.6 Worktop overhang

- ▶ Please note the worktop overhang x when creating the worktop cut-out. Applies to flush installation and surface mounting.

- i** In the case of cooktop extractor PKA3/PKA3AB combined with straight duct piece PKA1FEV, flush installation is also possible in a worktop with a depth ≥650 mm.

4.5.1 Flush installation

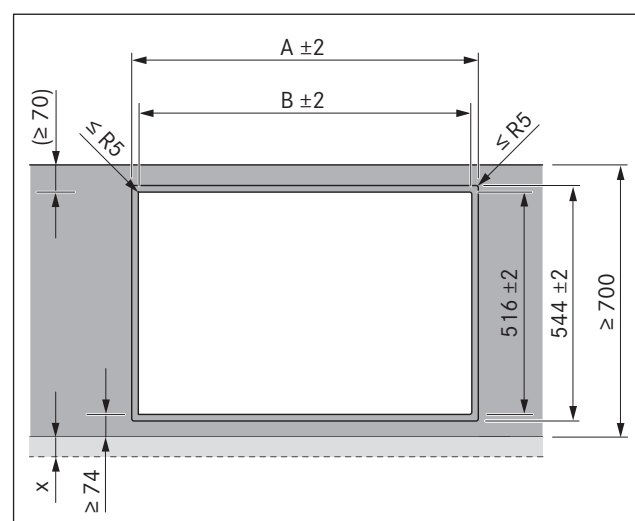

Fig. 4.7 Cut-out dimensions for flush installation

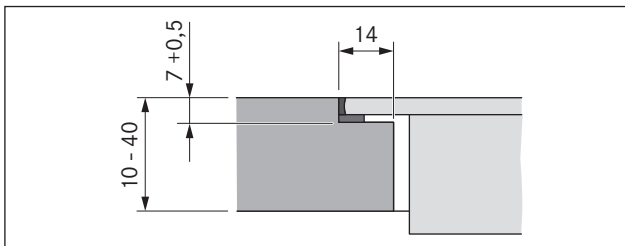

Fig. 4.8 Rebate dimensions for flush installation

Cooktops/cooktop extractor	A in mm	B in mm
	374	346
	485	457
	856	828
	1338	1310
	1709	1681

Tab. 4.3 Cut-out dimensions of the appliance combinations in the case of flush installation

4.5.2 Surface mounting

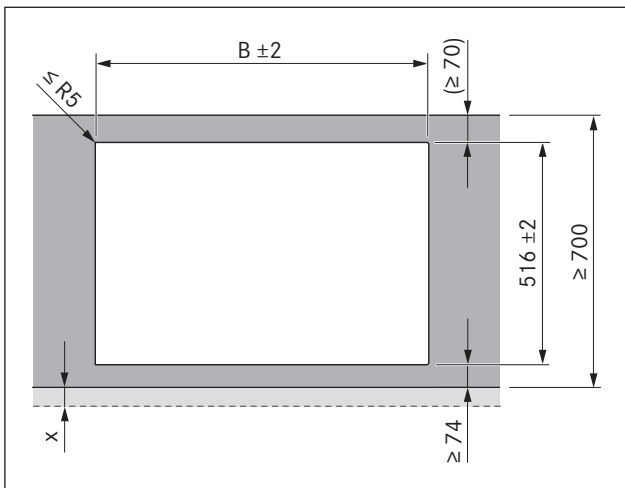

Fig. 4.9 Cut-out dimensions for surface mounting

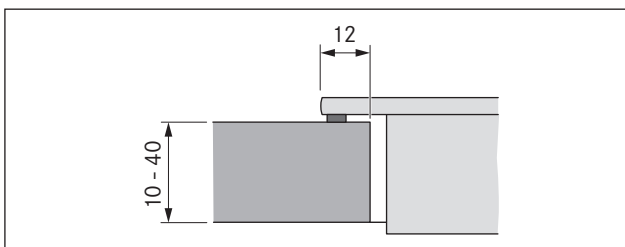

Fig. 4.10 Overlay dimensions for surface mounting

Cooktops/cooktop extractor	B in mm
	346
	457
	828
	1310
	1681

Tab. 4.4 Cut-out dimensions of the appliance combinations in the case of surface mounting

4.6 Installing the control knob in the floor unit front panel

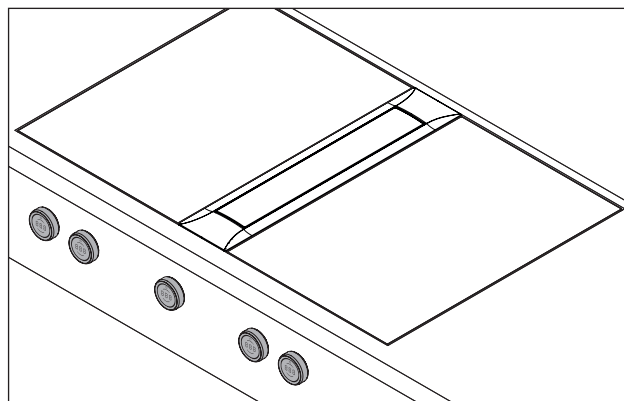

Fig. 4.11 Installed control knob

► Pre-drill all bore holes to prevent tearing out the fixed front panel.

4.6.1 Cooktop extractor bore holes

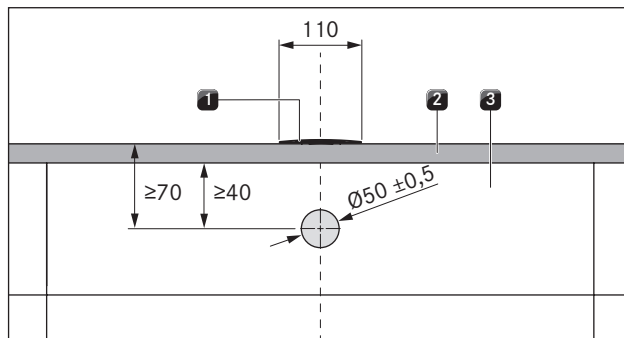

Fig. 4.12 Cooktop extractor drilling pattern

- [1] Cooktop extractor
- [2] Worktop
- [3] Fixed front panel

4.6.2 Example bore holes

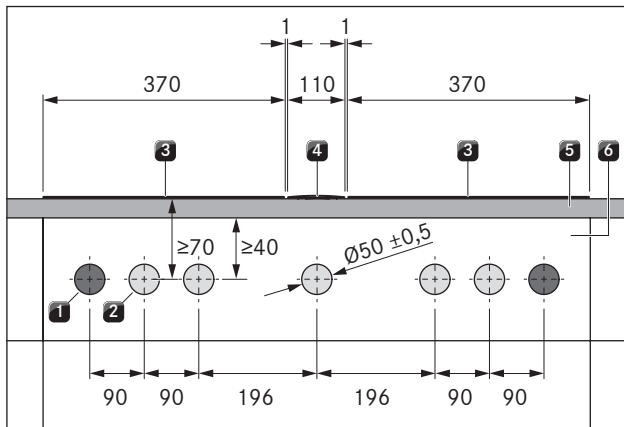

Fig. 4.13 Drilling pattern for 2 cooktops, 1 cooktop extractor and 2 sockets

- [1] Boreholes for socket (x 2 external)
- [2] Bore holes for control knobs (x 5)
- [3] Cooktop (x 2)
- [4] Cooktop extractor
- [5] Worktop
- [6] Fixed front panel

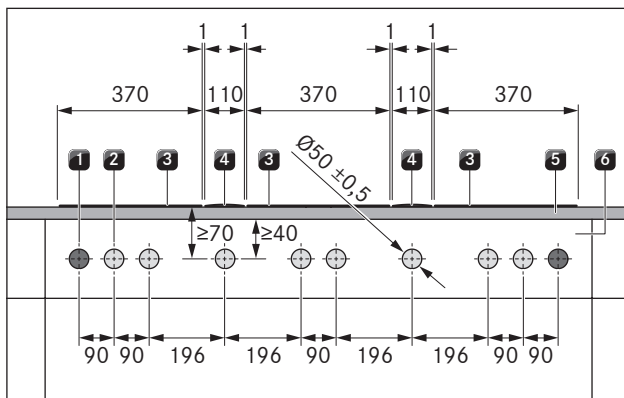

Fig. 4.14 Drilling pattern for 3 cooktops, 2 cooktop extractors and 2 sockets

- [1] Boreholes for socket (x 2 external)
- [2] Bore holes for control knobs (x 8)
- [3] Cooktop (x 3)
- [4] Cooktop extractor (x 2)
- [5] Worktop
- [6] Fixed front panel

4.6.3 Fitting the control knob

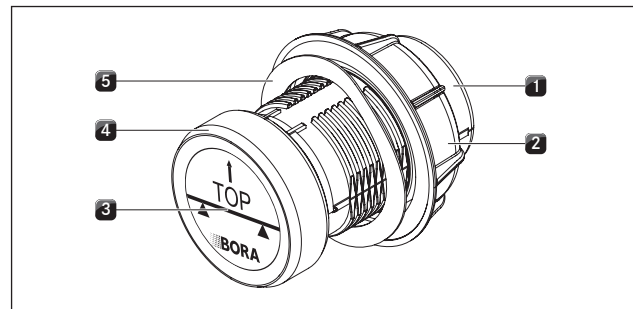

Fig. 4.15 Structure of control knob

- [1] Knob housing
- [2] Universal nut
- [3] Sticker
- [4] Knob ring
- [5] Wave spring

i In the case of steel fronts, wave springs must not be used. The corresponding installation steps are to be omitted.

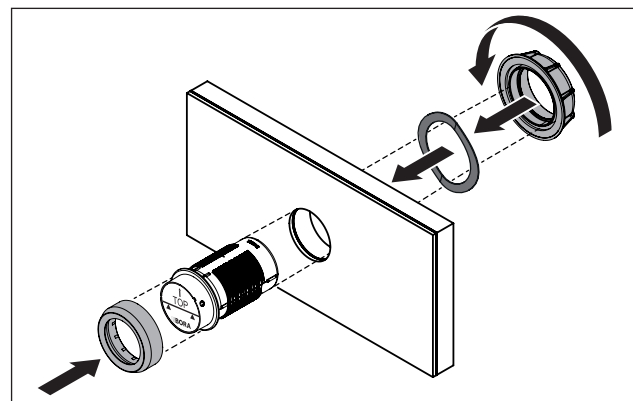

Fig. 4.16 Fitting the control knob

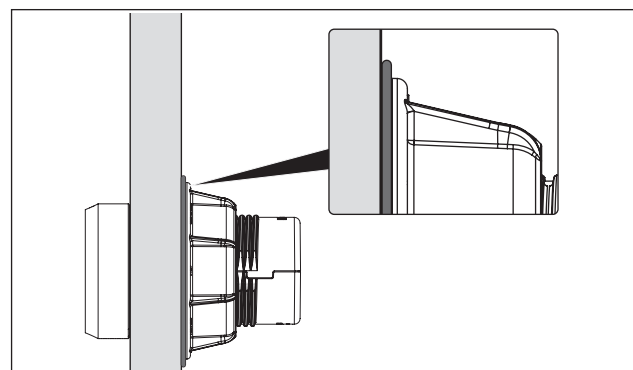

Fig. 4.17 Wave spring when installation is complete

- ▶ Remove the knob ring [4].
- ▶ Unscrew the universal nut [2].
- ▶ Remove the wave spring [5].
- ▶ Insert the knob housing [1] from the front through the hole in the panel.
- ▶ Attach the wave spring [5] to the knob housing [1] from the rear (not in the case of steel fronts).

- ▶ Screw the universal nut [2] onto the knob housing [1] from the rear and tighten a little.
- ▶ Align the knob housing [1] so it is level.
- ▶ Tighten the universal nut [2].
- The wave spring (if used) must be pressed flat.
- ▶ Remove the sticker [3].
- ▶ Place the knob ring [4] on the knob housing [1].

Additional step in the case of All Black cooktop extractors PKA3AB/PKAS3AB:

- ▶ Replace the cooktop knob rings with the black All Black knob rings PKR3AB (included in the scope of delivery of PKA3AB/PKAS3AB).

4.7 Planning variations for PKA3/PKA3AB

- i** With the PKA3/PKA3AB cooktop extractor, the air can be channelled off to the left or to the right, according to requirements.
- i** Thanks to the pre-assembled curved duct piece or the straight duct piece (included in the scope of delivery) the air can be channelled around a 90° bend to the rear or straight out to the side.
- i** When using the straight duct piece, an additional EFD shallow seal is required (not included in the scope of delivery).
- The cooktop extractor is delivered with a pre-assembled curved duct piece to the right.

4.7.1 Airflow straight to the side

- i** When the air is channelled straight out to the side, the cooktop can be installed rotated by 180°. In this case, the cover frame must also be turned (see „4.7.3 Rotating the cover frame by 180°“).

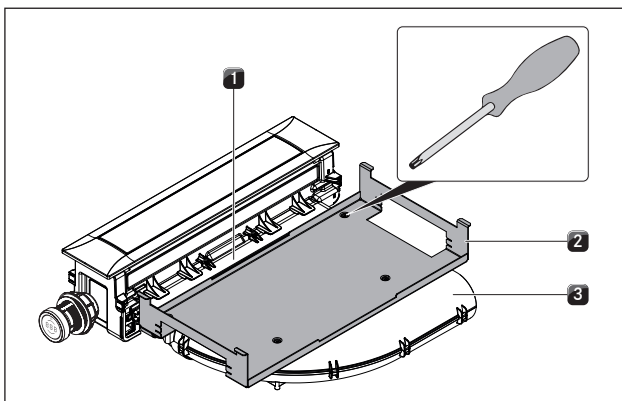

Fig. 4.18 Removing the holding plate

- [1] Duct piece adapter
- [2] Holding plate
- [3] Curved duct piece

- ▶ Unscrew the Torx screw (size 10) that attaches the holding plate [2] to the curved duct piece [3].
- ▶ Unscrew the 2 Torx screws (size 10) that attach the holding plate [2] to the duct piece adapter [1].
- ▶ Remove the holding plate [2].

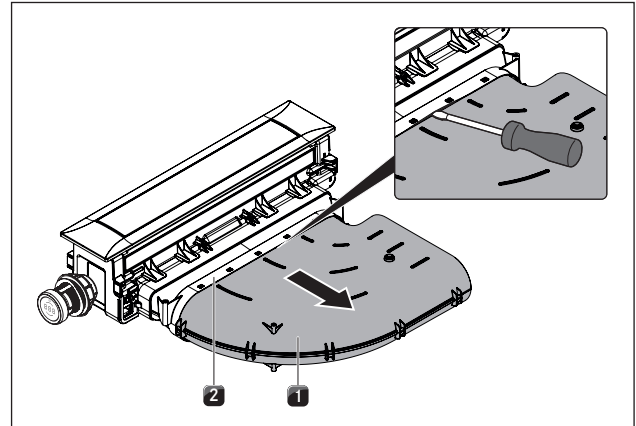

Fig. 4.19 Disassemble the curved duct piece

- [1] Curved duct piece
- [2] Duct piece adapter

- ▶ Separate the curved duct piece [1] from the duct piece adapter [2].
- ▶ To do this, carefully prise the plug connection open with a slotted screwdriver first.
- ▶ Pull the curved duct piece [1] out.
- ▶ If necessary, rotate the cover frame by 180° (see „4.7.3 Rotating the cover frame by 180°“).

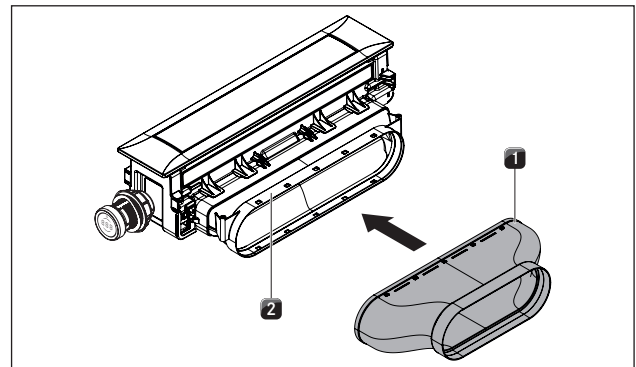

Fig. 4.20 Installing the straight duct piece

- [1] Straight duct piece
- [2] Duct piece adapter

- ▶ Push the straight duct piece [1] onto the duct piece adapter [2] until it clicks into place in the fastening lugs.
- ▶ Make sure that no air gap has formed between the components.
- ▶ Attach the holding plate to the duct piece adapter [2] with 2 screws only.

4.7.2 Airflow to the left (installation rotated by 180°)

- i** The PKA3/PKA3AB cooktop can be installed rotated by 180°, meaning that the air is channelled away to the left.

Airflow to the left with the curved duct piece

- ▶ Separate the holding plate and the curved duct piece (see „4.7.1 Airflow straight to the side“).
- ▶ Rotate the cover frame by 180° (see „4.7.3 Rotating the cover frame by 180°“).

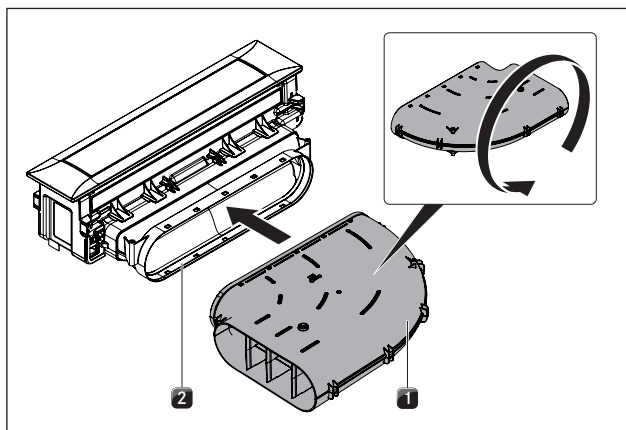

Fig. 4.21 Turning the curved duct piece over

- [1] Curved duct piece
[2] Duct piece adapter

- ▶ Turn the curved duct piece [1] over.
- ▶ Push the rotated curved duct piece [1] back onto the duct piece adapter [2] until it clicks into place in the fastening lugs.

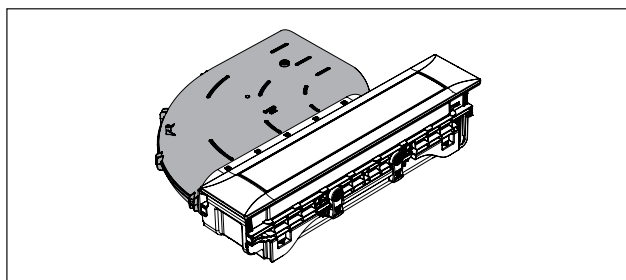

Fig. 4.22 Airflow to the left with the curved duct piece

- ▶ Make sure that no air gap has formed between the components.
- ▶ Attach the holding plate.

4.7.3 Rotating the cover frame by 180°

- i** To ensure correct orientation of the cover frame, this must also be rotated by 180°.

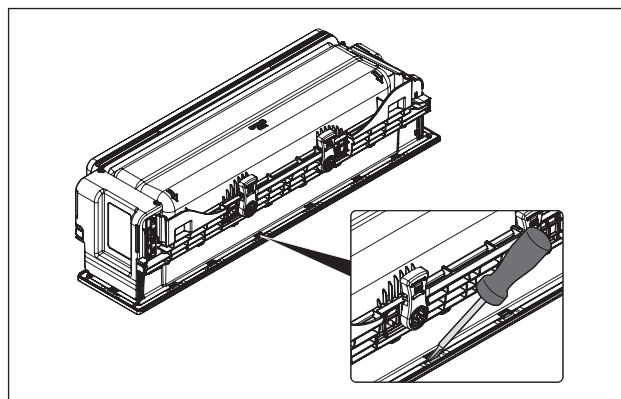

Fig. 4.23 Removing the cover frame

- ▶ Turn the cooktop extractor round and lay it carefully on a soft surface (e.g. a blanket) with the visible surface facing upwards.
- ▶ Carefully remove the holding clamps (x 18) with a screwdriver.

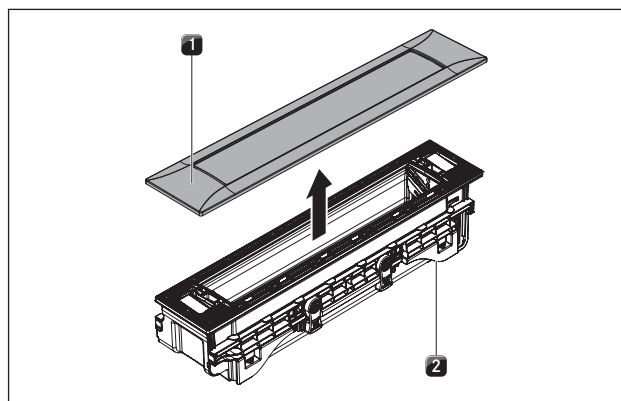

Fig. 4.24 Removing the cover frame

- [1] Cover frame
[2] Cooktop extractor

- ▶ Turn the cooktop extractor [2] round and remove the cover frame [1].
- ▶ Rotate the cover frame [1] by 180°.
- ▶ Put the cover frame [1] back on the cooktop extractor [2].
- ▶ Make sure that the holding clamps click into place.

4.8 Installing the cooktop extractor

- i** Clearance of one millimetre should be planned between the built-in appliances. When combined with a directly adjacent induction wok cooktop PKIW3, the plastic bar on the side of the cooktop extractor should be carefully removed with a utility knife.

- i** A clearance of two millimetres should be planned around the built-in appliances.

4.8.1 Fitting the cooktop extractor

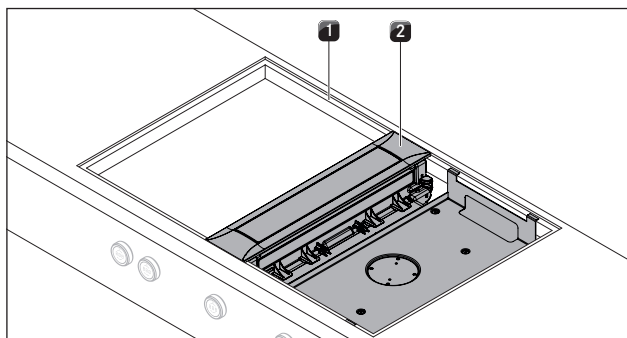

Fig. 4.25 Fitting the cooktop extractor

- [1] Worktop cut-out
- [2] Cooktop extractor

- ▶ Place the cooktop extractor [2] in the middle of the worktop cut-out [1] provided.
- ▶ Position the cooktop extractor [2] with precision.

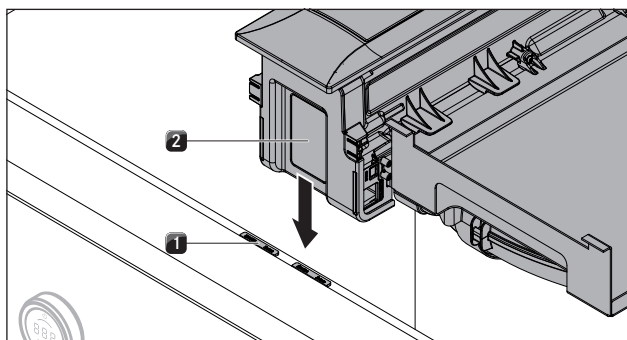

Fig. 4.26 Height adjustment plates

- [1] Height adjustment plate
- [2] Cooktop extractor

- ▶ If applicable, insert the height adjustment plates [1].

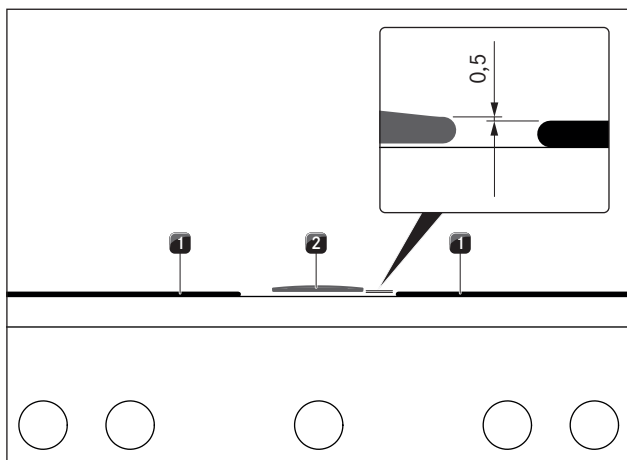

Fig. 4.27 Installing the cooktop extractor

- [1] Cooktop
- [2] Cooktop extractor

- The cooktop extractor [2] is to be installed 0.5 mm higher than the cooktops [1].

4.8.2 Securing the cooktop extractor

The cooktop extractor is secured using the four mounting brackets provided. The mounting brackets have offset fastening lugs, with one side for surface mounting and another for flush installation. The mounting brackets can be adjusted to the thickness of the worktop.

Preparing the mounting brackets

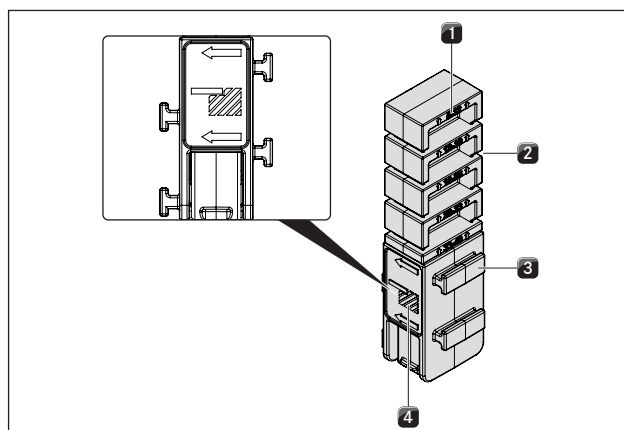

Fig. 4.28 Mounting bracket - right side (flush installation)

- [1] Worktop thickness lettering (in mm)
- [2] Cut marks (x 4)
- [3] Fastening lugs (2 on each side)
- [4] Marking for flush installation

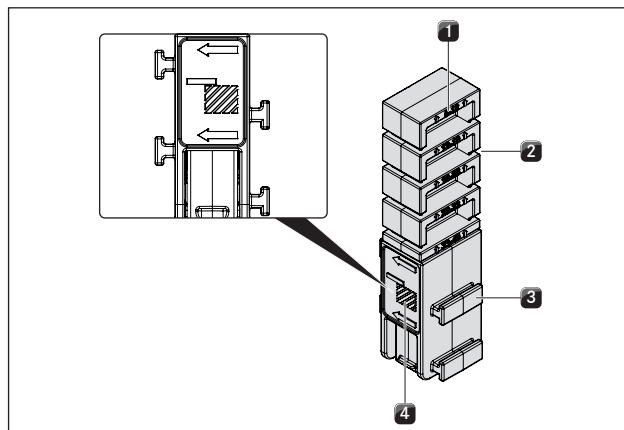

Fig. 4.29 Mounting bracket - left side (surface mounting)

- [1] Worktop thickness lettering (in mm)
- [2] Cut marks (x 4)
- [3] Fastening lugs (2 on each side)
- [4] Marking for surface mounting

i The symbols on the mounting brackets show which side to use for surface mounting and which to use for flush installation.

i The lettering shows the cutting mark corresponding to the worktop thickness.

- ▶ If necessary, shorten the mounting brackets according to the thickness of the worktop.

- ▶ To do this, cut the mounting brackets at the appropriate cut marks using a utility knife.
- ▶ Depending on the installation type, turn the mounting brackets to the left or right (flush installation or surface mounting).

Securing the cooktop extractor

i The cooktop extractor is secured using the 4 mounting brackets provided, for which there are 4 alternative positions on the holding plate.

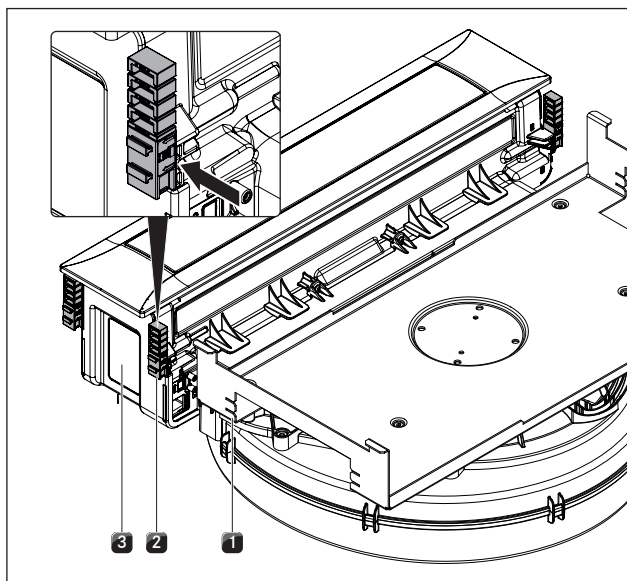

Fig. 4.30 Pushing on the mounting brackets

- [1] Alternative position for mounting bracket
- [2] Mounting bracket
- [3] Cooktop extractor

- ▶ Push the mounting brackets [2] into the holders provided on the cooktop extractor [3] or the alternative positions on the holding plate [1].

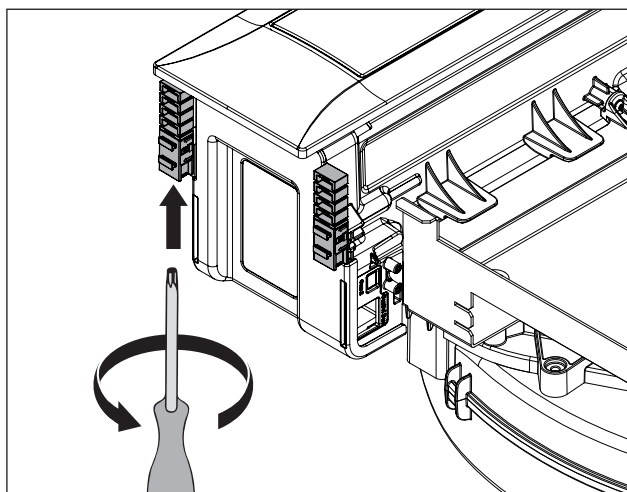

Fig. 4.31 Tightening the mounting clamps

- ▶ Use a Torx 20 screwdriver to tighten the mounting brackets slightly from underneath.
- ▶ Verify that the alignment is correct.

4.9 Installing the duct system

4.9.1 Duct connection dimensions

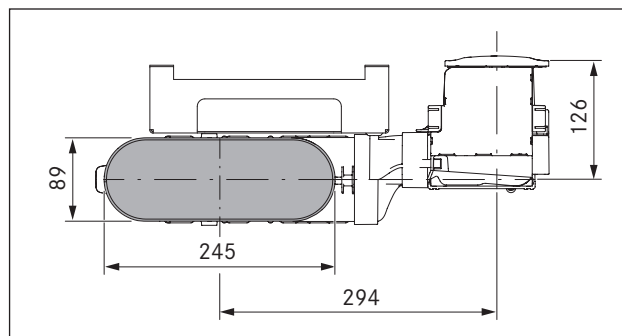

Fig. 4.32 Duct connection dimensions for PKA3/PKA3AB with the curved duct piece

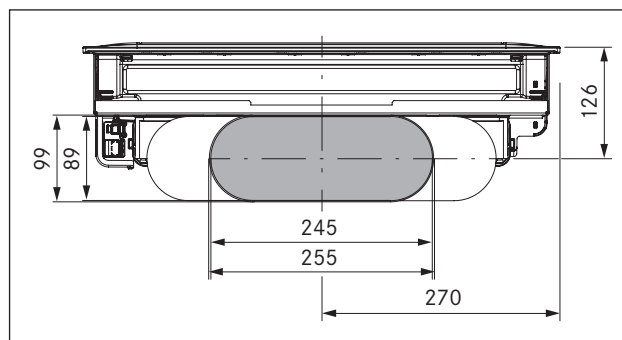

Fig. 4.33 Duct connection dimensions for PKA3/PKA3AB with the straight duct piece

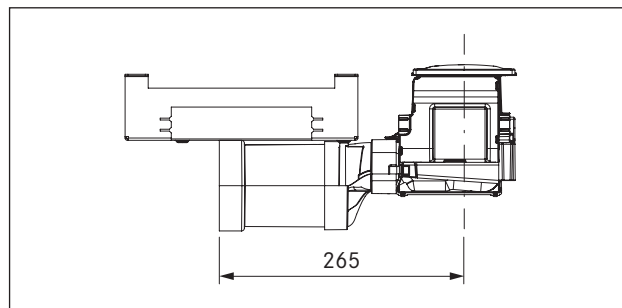

Fig. 4.34 Duct connection dimensions for PKA3/PKA3AB with the straight duct piece

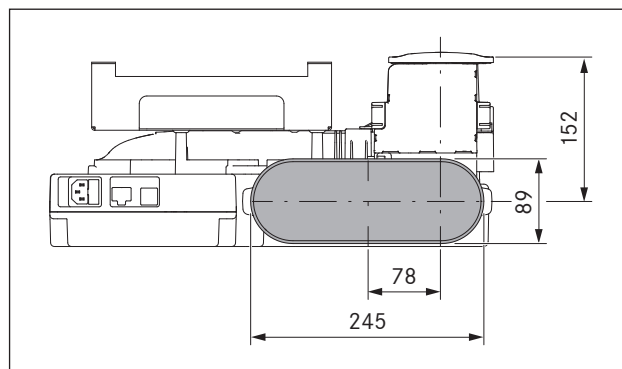

Fig. 4.35 Duct connection dimensions for PKAS3, PKAS3AB

4.9.2 Preparing for installation

i When attaching the seals, ensure that an airtight seal is created with the connecting duct piece when the seals are compressed.

- ▶ Adjust the ducting parts to the height of the worktop.
- ▶ Saw out the necessary cut-outs for the ducting in the back panel of the floor unit.

4.9.3 Connecting the duct system to the appliance

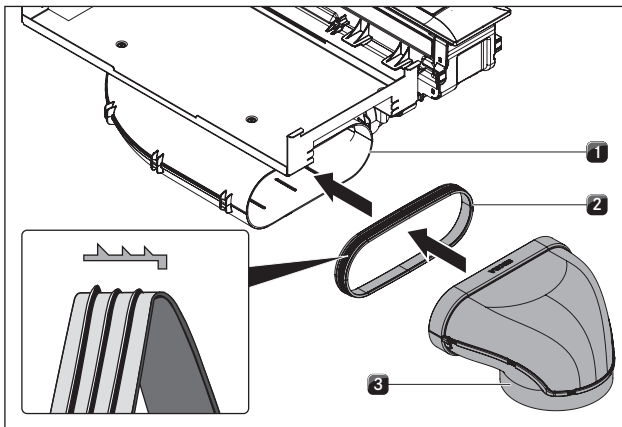

Fig. 4.36 Connecting to the duct system

- [1] Output nozzles
- [2] Seal
- [3] Duct piece

- ▶ Push the seal [2] onto the outlet nozzle [1] on the appliance. To do this, the seal [2] will need to be stretched slightly.
- ▶ Push the duct part to be connected [3] with the coupling onto the outlet nozzle [1] with the seal [2].
- ▶ Ensure that the seal [2] is not displaced.

4.9.4 Standard set-up for PKA3/PKA3AB

Preparing for installation of cooktop extractor PKA3/PKA3AB

i The floor unit must not be supported by the plinth fan housing.

- ▶ Depending on the installation situation, adjust the levelling feet on the floor unit as necessary.

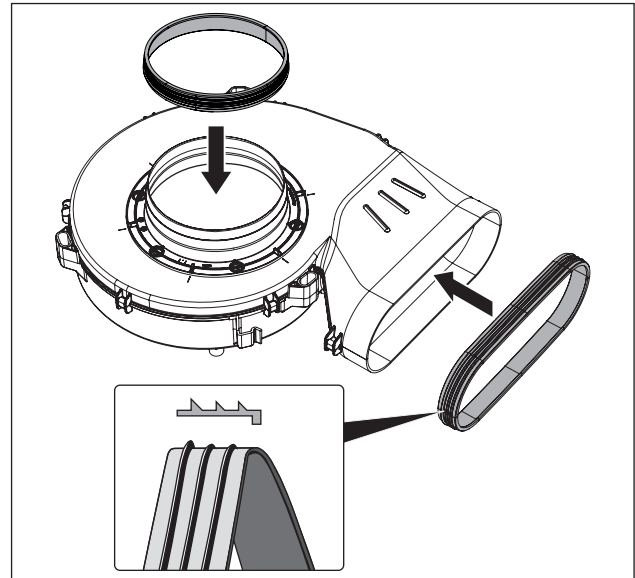

Fig. 4.37 Attaching the seals to the plinth fan inlet and outlet nozzles

- ▶ Push the round seal onto the plinth fan inlet nozzle.
- ▶ Push the shallow seal onto the plinth fan outlet nozzle.
- To do this, the seals will need to be stretched slightly.

Standard set-up for PKA3/PKA3AB

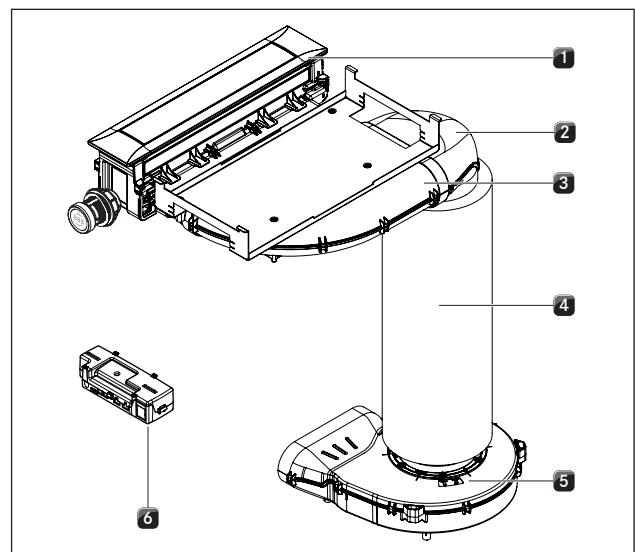

Fig. 4.38 Standard set-up for PKA3/PKA3AB

- [1] Cooktop extractor
- [2] 90° diverter
- [3] Curved duct piece
- [4] Silencer
- [5] Universal plinth fan
- [6] Control unit

- ▶ Push the 90° diverter [2] onto the curved duct piece [3].
- ▶ Position the plinth fan [5].
- To facilitate positioning, the inlet nozzle on the plinth fan can be removed. To do this, please see the assembly instructions for the Universal plinth fan ULS.
- ▶ Connect the silencer [4] to the plinth fan [5].
- ▶ Connect the silencer [4] to the 90° diverter [2].

- You can optimally stick the joins between the ducting sections and the plinth fan together with UDB sealing tape.

i Position the plinth fan and the control unit in such a way that they are easily accessible and removable for maintenance work.

- The maximum exhaust air duct length with a fan is 6 m.
- The minimum cross-section of the air ducts must be 176 cm², which equates to a round pipe with a diameter of 150 mm or the BORA Ecotube duct system.
- For the ducting, only use BORA Ecotube duct elements with smooth pipe interiors. Do not use flexible or fabric tubes.

4.9.5 Installing the additional fan

- ▶ Install the additional fan in the exhaust duct.
- ▶ Ensure that a minimum clearance of 3 m is maintained between the fan units.
- ▶ Only use BORA universal fans with your BORA cooktop extractor system.

4.10 Connecting external switch contacts

i The Home In and Home Out communication connections must only be connected by a certified specialist. The specialist also assumes responsibility for the proper installation and commissioning.

i The electronic unit can contain residual charge. You must therefore be careful not to touch the exposed contacts on the electronic unit!

When using Home In and Home Out, you will require the relevant documents for the external switch devices in order to ensure safe device connection and operation.

The following switch contacts can be used:

Contact	Function	Connection
Home In	Cooktop extractor on/off connection for external switch contact (contact closed: cooktop extractor on)	24 V DC 100 mA
Home Out	Electrically isolated contact for controlling external installations of the cooktop extractor (cooktop extractor on: contact closed)	maximum 250 VAC/30 VDC, depending on the operating status 2.5 A

Tab. 4.5 Switch contacts

i The Home In contact can be used for external safety devices (e.g. window contact switches). If the switch is open, the cooktop extractor is off.

4.10.1 Preparing PKAS3/PKAS3AB

i So that the top of the appliance is not scratched during installation, it must be placed on a protective base (e.g. cardboard).

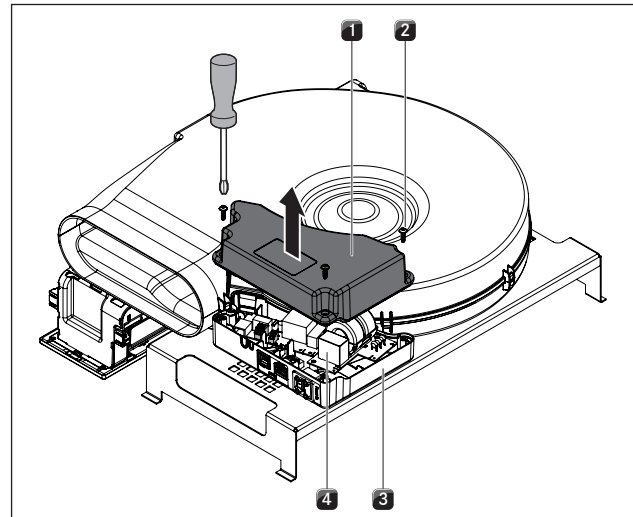

Fig. 4.39 Opening the control unit housing cover

- [1] Housing cover
- [2] Screw (x 3)
- [3] Housing
- [4] Electronic unit

- ▶ Spread out a base to protect the surface.
- ▶ Turn the cooktop extractor system over and lay it upside down on the base.
- ▶ Undo the control unit screws [2] on the bottom of the cooktop extractor system.
- ▶ Remove the housing cover [1] from the housing [3].
- ▶ Do not touch the electronic unit [4].

4.10.2 Preparing the control unit on PKA3/PKA3AB

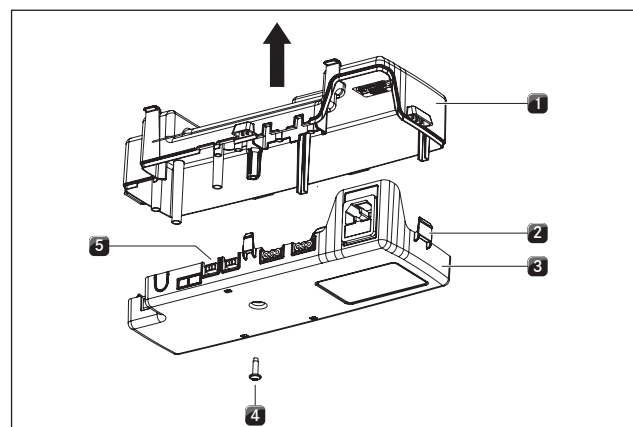

Fig. 4.40 Opening the control unit housing cover

- [1] Housing cover
- [2] Locks
- [3] Housing subshell
- [4] Screw
- [5] Electronic unit

- ▶ Ensure that the control unit is disconnected from the power supply.
- ▶ Undo the screw [4] on the housing cover [1].
- ▶ Carefully release all locks [2] with a slotted screw driver.
- ▶ Remove the housing cover [1] from the housing subshell [3] by lifting it up.
- ▶ Do not touch the electronic unit [5].

4.10.3 Preparing connection cables for external switching equipment

Use connection cables of the following types to connect external switch devices.

Contact	Connection cable
Home In	H03VV-F 2 x 0.5 mm ²
Home Out	H05VV-F 2 x 1 mm ²

Tab. 4.6 Connection cable

- i** The connection cable is only intended for internal use in buildings, private households, kitchens or offices!
 - i** The overall length of the connection cable for external switching equipment must not exceed 10 m!
- ▶ Prepare the connection cable in accordance with the prescribed stripping lengths.

PKA3/PKA3AB

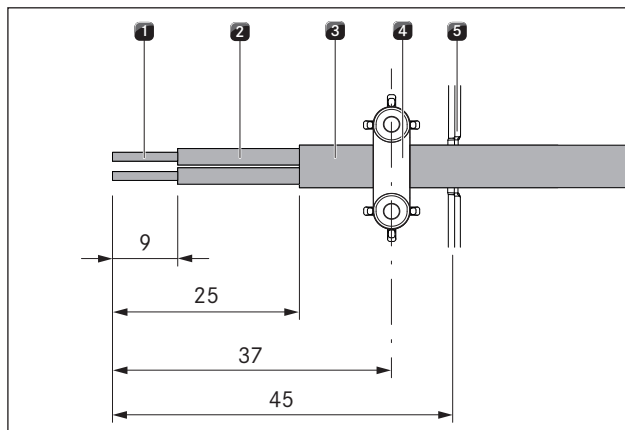

Fig. 4.41 Stripping lengths and installation position of the PKA3/PKA3AB connection cable

- [1] Stripped wire end
- [2] Insulated wire
- [3] Jacketed cable
- [4] Strain relief clamp
- [5] Cable feed snap-out element

- ▶ Please adhere to the maximum stripping length of the individual wires of 9 mm on the stripped wire end [1].
- ▶ Please adhere to the maximum stripping length of the outer sheath of 25 mm on the insulated wire [2].

PKAS3/PKAS3AB

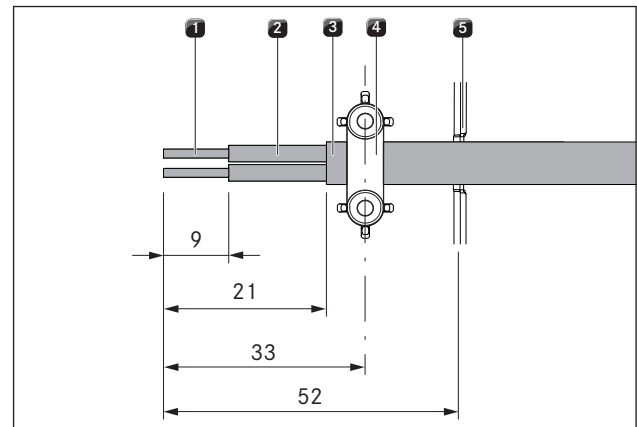

Fig. 4.42 Stripping lengths and installation position of the PKAS3/PKAS3AB connection cable – Home In

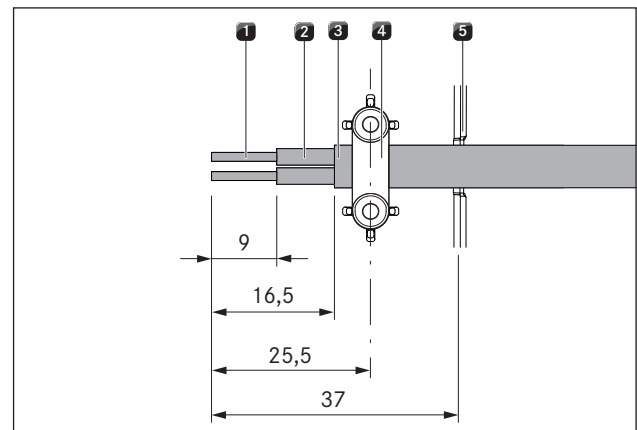

Fig. 4.43 Stripping lengths and installation position of the PKAS3/PKAS3AB connection cable – Home Out

- [1] Stripped wire end
- [2] Insulated wire
- [3] Jacketed cable
- [4] Strain relief clamp
- [5] Cable feed snap-out element

- ▶ Please adhere to the maximum stripping length of the individual wires of 9 mm on the stripped wire end [1].
- ▶ Please adhere to the maximum stripping length of the outer sheath of 21 mm (Home In) and 16.5 mm (Home Out) on the insulated wire [2].

4.10.4 Installing the external switch device

Depending on the type of switch device, connect the connection cables to either the Home In or the Home Out connection clamp.

- ▶ Adhere to the connection diagram when connecting Home In and Home Out.

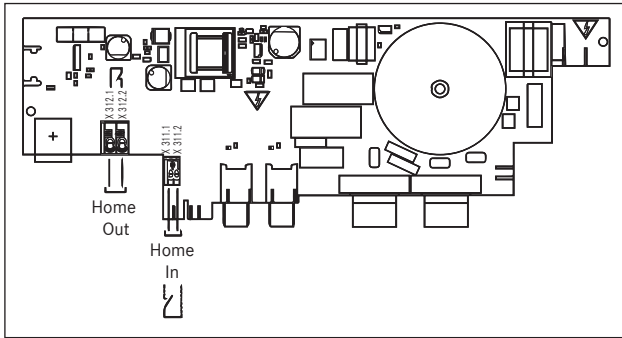

Fig. 4.44 Connection diagram for PKA3/PKA3AB external switch contact

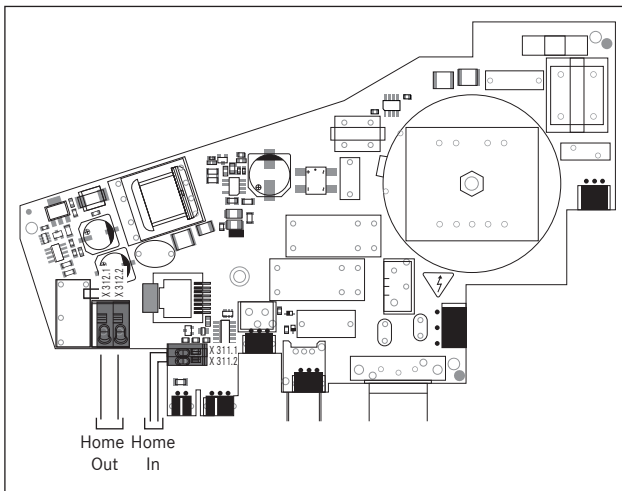

Fig. 4.45 Connection diagram for PKAS3/PKAS3AB external switch contact

- ▶ Connect the cable for the relevant contact to the switch contact clamp in accordance with the connection diagram.
- In order to connect the Home In interface, the installed bridge must be removed.

i The Home In contact must be bridged if this is not used (bridged on delivery).

i For connections to the Home In connection clamp, no ferrules may be used.

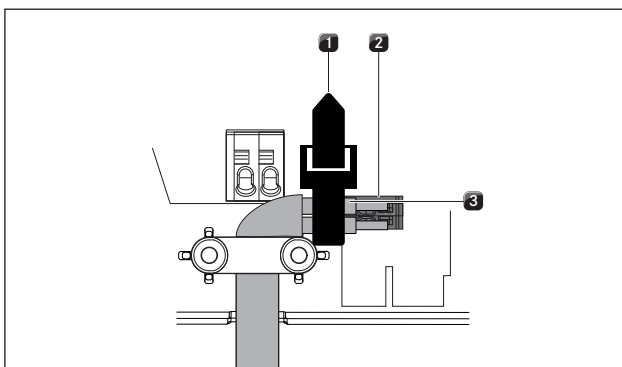

Fig. 4.46 Cable tie Home-In interface PKAS3/PKAS3AB

- [1] Cable tie
- [2] Home-In interface PKAS3/PKAS3AB
- [3] Insulated wire

i If the Home-In interface is connected to PKAS3/PKAS3AB, the two insulated wires of the connection cable must be joined together with a cable tie.

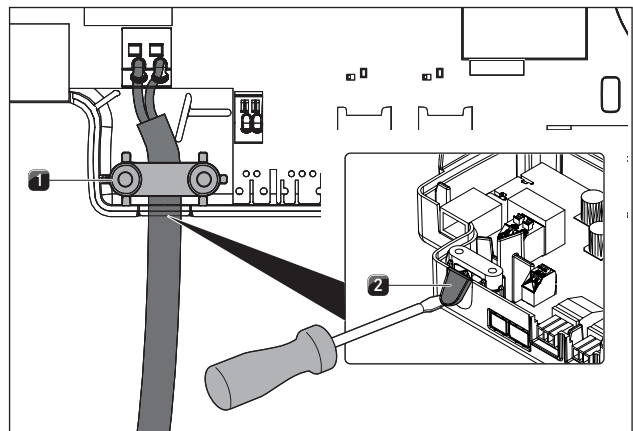

Fig. 4.47 Home Out contacts with strain relief

- [1] Strain relief clamp
- [2] Snap-out element for cable feed

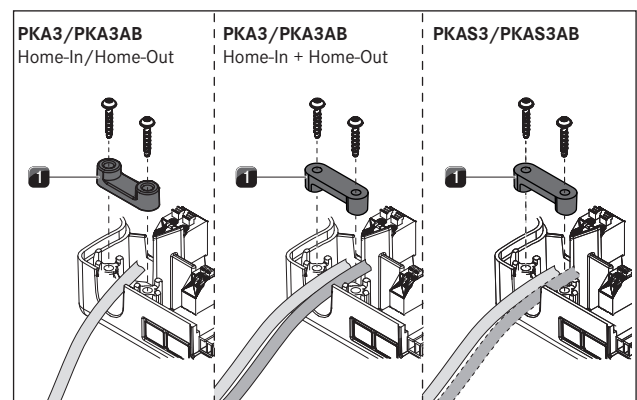

Fig. 4.48 Fitting the strain relief clamp

- [1] Strain relief clamp

- ▶ Remove the snap-out element [2] required for the cable feed from the plastic housing of the control unit.
- ▶ Clamp the connection cable in the strain relief clamp [1] provided in accordance with the wire cross section or number of cables used.

i Any production residues on the cable clamp (e.g. protruding nibs) must be removed in order to guarantee a proper fit.

i If external switching devices are connected both to the Home In and Home Out interfaces, both cables should be secured with the strain relief clamp.

- ▶ Check the correct installation, as well as the firm positioning of the connection cables.
- ▶ Close and secure the control unit cover.
- ▶ Screw down the lid with the screw provided (max. 2 Nm).
- ▶ Make sure that the cable is not damaged or trapped.

4.11 Establishing communication and power connection

- ▶ Observe all safety and warning information (see „2 Safety“).
- The plug for the mains supply cable must be accessible following installation.
- If the mains supply cable has been damaged this must be replaced.

i The appliance components are linked by the ribbon cable provided.

4.11.1 Connecting the control knobs

i Control knobs must only be connected to the ports provided on the appliance.

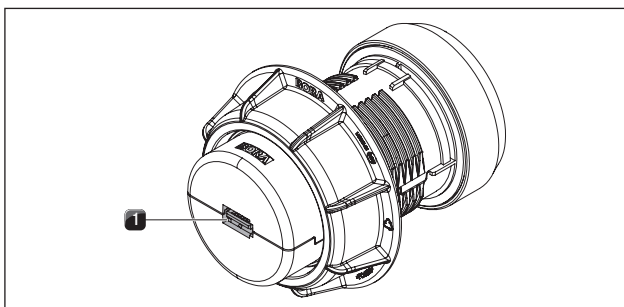

Fig. 4.49 Back of control knob with port

[1] Port on the back of the control knob

- ▶ Connect the control knobs to the appliances.

Connecting the control knobs to the cooktop extractor

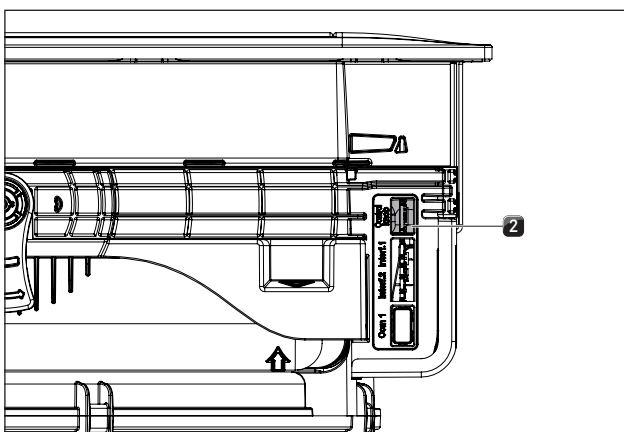

Fig. 4.50 Ports on the side of the cooktop extractor

[2] Control knob port

- ▶ Connect the port on the back of the control knob [1] to the port provided on the side of the cooktop extractor [2].

4.11.2 Ports on cooktop extractor system PKAS3/PKAS3AB

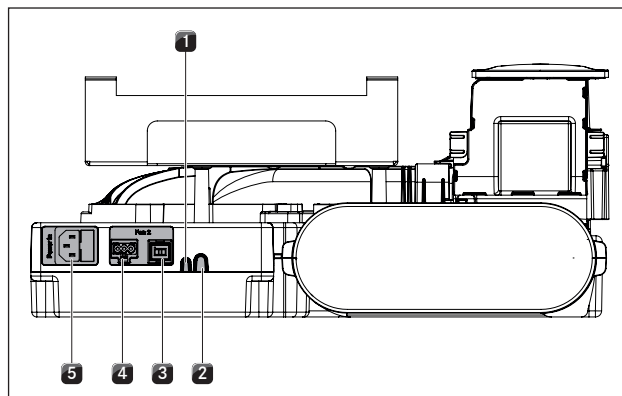

Fig. 4.51 Rear ports on PKAS3 and PKAS3AB

- [1] Home In
- [2] Home Out
- [3] Additional fan control line
- [4] Additional fan power supply cable
- [5] Power supply cable with microfuse

Connecting an additional fan

- ▶ Connect the additional fan control line to the port [3] provided on the back of the appliance.
- ▶ Connect the additional fan power supply cable to the port [4] provided on the back of the appliance.
- ▶ Check all the plug connections to ensure that they are secure.

4.11.3 Connecting cooktop extractor PKA3/PKA3AB

Connecting the control unit and fan to the cooktop extractor

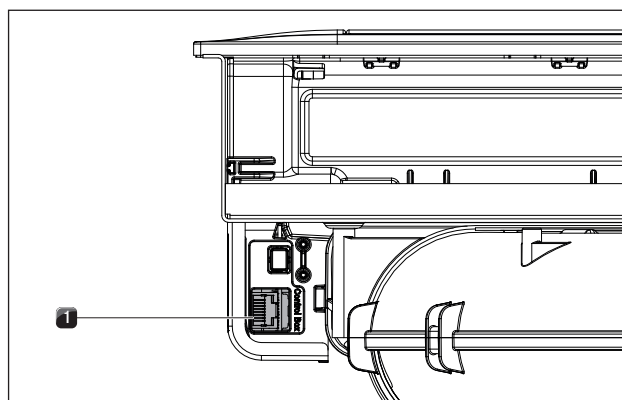

Fig. 4.52 Side port for the control unit on cooktop extractor PKA3/PKA3AB

[1] Control unit port

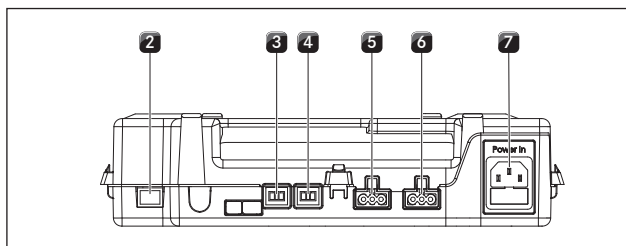

Fig. 4.53 Control unit ports

- [2] CAT 5e communication cable
- [3] Fan 1 control line
- [4] Fan 2 control line
- [5] Fan 1 power supply cable
- [6] Fan 2 power supply cable
- [7] Power supply cable with microfuse

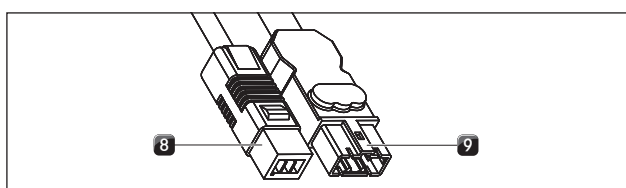

Fig. 4.54 Plinth fan connection plugs

- [8] Plinth fan control line connection plug
- [9] Plinth fan power supply cable connection plug

- ▶ Using the CAT 5e communication cable (included in the scope of delivery) connect the port on the side of the cooktop extractor [1] to the port on the control unit [2].
- ▶ Connect the plinth fan control line [8] to the control unit [3].
- ▶ Connect the plinth fan power supply cable [9] to the control unit [5].

Removing the power supply cable

To remove the power supply cable [1] from the control unit [6] you need a small slotted screwdriver.

- ▶ Disconnect the control unit power supply cable from the power supply [8].
- ▶ Make sure that there is no power to the appliance.
- ▶ Use the slotted screwdriver to undo the lock on the fan power supply cable plug.
- ▶ To do this, insert the slotted screwdriver into the gap in the socket.
- ▶ Press the lock down gently.
- ▶ Use the slotted screwdriver to gently lever the power supply cable plug out of the control unit socket.
- ▶ Now disconnect the power supply cable from the socket.
- ▶ Check the plug and the socket for damage.
- ▶ Do not use damaged components.
- ▶ Contact your specialist BORA retailer to replace any damaged components.

Connecting an additional fan

- ▶ Connect the fan control line [8] to the control unit [4].
- ▶ Connect the fan power supply cable [9] to the control unit [6].
- ▶ Check all the plug connections to ensure that they are secure.

4.11.4 Establishing contact between the cooktop extractor and cooktops

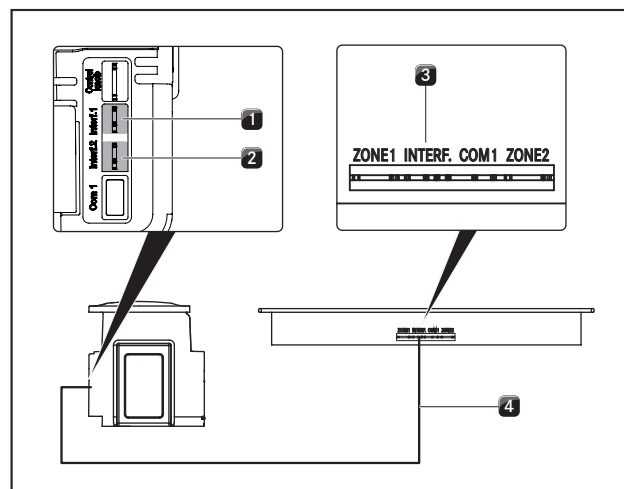

Fig. 4.55 Establishing contact between the cooktop extractor and cooktops

- [1] Cooktop extractor communication cable port for left cooktop
- [2] Cooktop extractor communication cable port for right cooktop
- [3] Cooktop communication cable port
- [4] ribbon cable

- ▶ Using the communication ports provided, connect the cooktop extractor [1]/[2] to the cooktop or cooktops [3].
- ▶ Only use the cables supplied in the scope of delivery.

i The full range of functions on the appliances will only be available if the cooktop extractor and cooktops are connected correctly.

4.11.5 Connecting the power supply

- ▶ Observe all national and regional laws and regulations as well as the supplementary regulations of the local utility companies.

i The appliances may only be connected to the mains power supply by certified specialists. The specialist also assumes responsibility for the proper installation and commissioning.

Connection diagrams

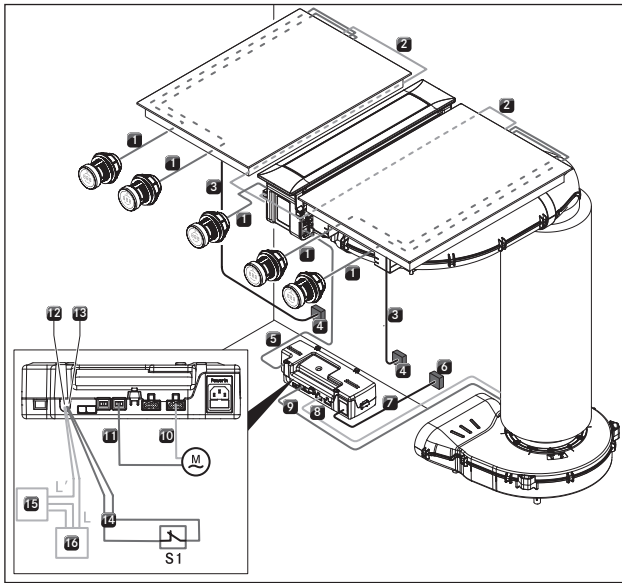

Fig. 4.56 PKA3/PKA3AB connection diagram

- [1] Interface/control knob cable
- [2] Cooktop communication cable
- [3] Cooktop power supply cable
- [4] Power supply for each cooktop
- [5] CAT 5e communication cable
- [6] Control unit power supply
- [7] Control unit power supply cable (country-specific)
- [8] Fan 1 power supply cable
- [9] Fan 1 control line
- [10] Fan 2 power supply cable
- [11] Fan 2 control line
- [12] Home Out port
- [13] Home In port
- [14] Home In connection cable
- [15] External device
- [16] Power supply for external device
- [M] Fan 2
- [S1] External switch contact

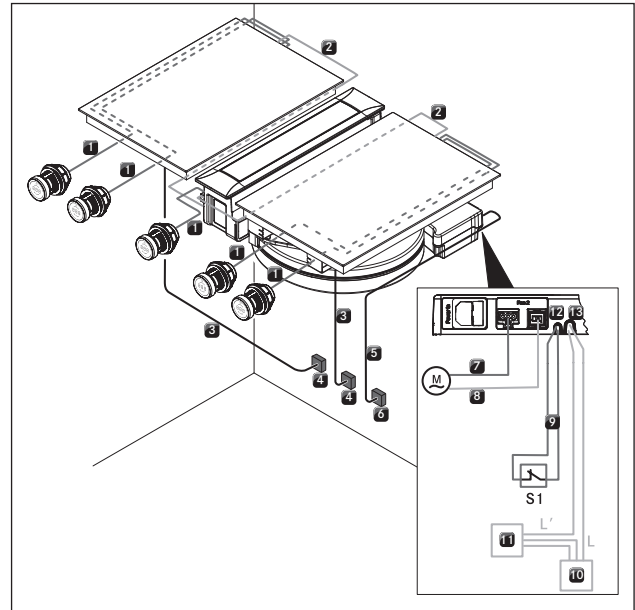

Fig. 4.57 PKAS3/PKAS3AB connection diagram

- [1] Interface/control knob cable
- [2] Cooktop communication cable
- [3] Cooktop power supply cable
- [4] Power supply for each cooktop
- [5] PKAS3/PKAS3AB power supply cable (country-specific)
- [6] PKAS3/PKAS3AB power supply
- [7] Fan 2 power supply cable
- [8] Fan 2 control line
- [9] Home In connection cable
- [10] Power supply for external device
- [11] External device
- [12] Home In port
- [13] Home Out port
- [M] Fan 2
- [S1] External switch contact

Connecting the cooktop extractor to the power supply

- ▶ Connect the extractor system (PKAS3, PKAS3AB) power supply cable and the control unit (PKA3/PKA3AB) power supply cable respectively to the power supply.
- ▶ Put the cooktop extractor into operation (see Operating instruction).
- ▶ Check that all the functions are working correctly.

4.12 Basic configuration

When installation is complete, you must carry out the basic settings (these settings can be changed at any time later on).

- i** You can see precise instructions on the basic configuration and all necessary information in the “Configuration menu” chapter of the operating instructions.

4.13 Initial operation

- i** Detailed information on how to use the BORA Professional 3.0 system can be found in the cooktop extractor's operating instructions..
- ▶ Ensure that all appliances are connected correctly and connected to the power supply (fused) prior to initial operation.
- Exception: During initial operation, the kitchen fitter may use a temporary power supply for the control unit in order to carry out the basic configuration (e.g. using the site power supply during the building phase).
- The settings made are saved and will not be affected when the system is disconnected from the mains.
- The final mains connection to the appliances may only be set up by certified specialists.

4.14 Function test

- ▶ Carry out a thorough function test on all appliances.
- ▶ In the event of error messages, see the "Troubleshooting" chapter in the operating instructions.

4.15 Sealing the appliances

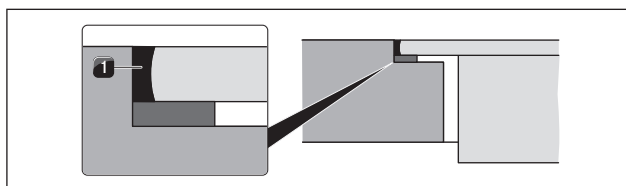

Fig. 4.58 Silicone sealant for flush installation

[1] Black, heat-resistant silicone sealant

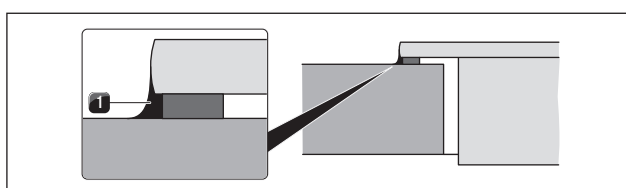

Fig. 4.59 Silicone sealant for surface mounting

[1] Black, heat-resistant silicone sealant

- ▶ Once all of the installation work and initial operation is complete, seal the appliances all the way round (also between the cooktop extractor and cooktop) with black, heat-resistant silicone sealant [1].
- ▶ Make sure that no silicone sealant gets under the cooktop.

4.16 Handover to user

Once installation is complete:

- ▶ Explain the main functions to the user.
- ▶ Explain all safety-related aspects of operation and handling to the user.
- ▶ Affix the supplied nameplate to the back of these instructions.
- ▶ Provide the user with the accessories and all accompanying documents, which are to be kept in a safe place.

5 Decommissioning, disassembly and disposal

- ▶ Observe all safety and warning information (see the Safety section).
- ▶ Follow the enclosed manufacturer's information.

5.1 Decommissioning

Decommissioning is understood as final shutdown and disassembly. Following decommissioning, the device can either be installed into other units, sold on privately or disposed of.

- i** Electricity and gas connections may only be disconnected by qualified specialists.
- ▶ To decommission, switch the device off (see Operation section)
- ▶ Disconnect the device from the power supply.

5.2 Disassembly

For removal, the device must be accessible for disassembly and disconnected from the power supply.

- ▶ Undo the appliance fixture.
- ▶ Remove the silicone joints.
- ▶ Disconnect the device from the extractor duct.
- ▶ Remove the device from the worktop by lifting it upwards.
- ▶ Remove any other accessories.
- ▶ Dispose of the old device and any contaminated accessories as described under "Environmentally-friendly disposal".

5.3 Environmentally-friendly disposal

Disposal of transport packaging

- i** The packaging protects the device from damage in transport. The packaging materials have been selected from environmental and disposal perspectives and are therefore recyclable.

Returning the packaging to the materials cycle saves resources and reduces waste volumes. Your specialist supplier will take the packaging back.

- ▶ Give the packaging to your specialist supplier or
- ▶ Dispose of the packaging properly in line with local regulations.

Disposal of old appliance



Electrical devices marked with this label may not be disposed of in domestic waste at the end of their service life. They must be disposed of at a collection point for the recycling of old electrical or electronic devices. You can find information from your city or district council.

Many electrical and electronic devices still contain valuable materials. But they also contain damaging materials which were necessary for them to function properly and safely. These can damage human health or the environment if disposed of improperly or incorrectly handled.

- ▶ Never put your old appliance in domestic waste.
- ▶ Take the old appliance to a regional collection point for return and recycling electrical and electronic components and other materials.

6 Notes

Installation instructions:

Original

Translation

Manufacturer: BORA Vertriebs GmbH & Co KG

The distribution and duplication of this document, as well as the use and disclosure of its contents are prohibited unless expressly authorised.

These operating and installation instructions have been drawn up with the greatest of care. But it cannot be ruled out that subsequent technical modifications have not yet been incorporated or the relevant content has not yet been adapted. Please accept our apologies in this eventuality. An updated version can be requested from the BORA Service Team. Subject to printing errors and mistakes.

© BORA Vertriebs GmbH & Co KG

All rights reserved.

(D)

BORA Lüftungstechnik GmbH

Rosenheimer Str. 33
83064 Raubling
Germany
T +49 (0) 8035 / 9840-0
F +49 (0) 8035 / 9840-300
info@bora.com
www.bora.com

(A)

BORA Vertriebs GmbH & Co KG

Innstraße 1
6342 Niederndorf
Austria
T +43 (0) 5373 / 62250-0
F +43 (0) 5373 / 62250-90
mail@bora.com
www.bora.com

(INT)

BORA Holding GmbH

Innstraße 1
6342 Niederndorf
Austria
T +43 (0) 5373 / 62250-0
F +43 (0) 5373 / 62250-90
mail@bora.com
www.bora.com

(AU) (NZ)

BORA APAC Pty Ltd

100 Victoria Road
Drummoyne NSW 2047
Australien
T +61 2 9719 2350
F +61 2 8076 3514
info@boraapac.com.au
www.bora-australia.com.au

