

**EN** Operating and installation instructions PFI 1 1

Surface induction glass ceramic cooktop with 2 cooking zones

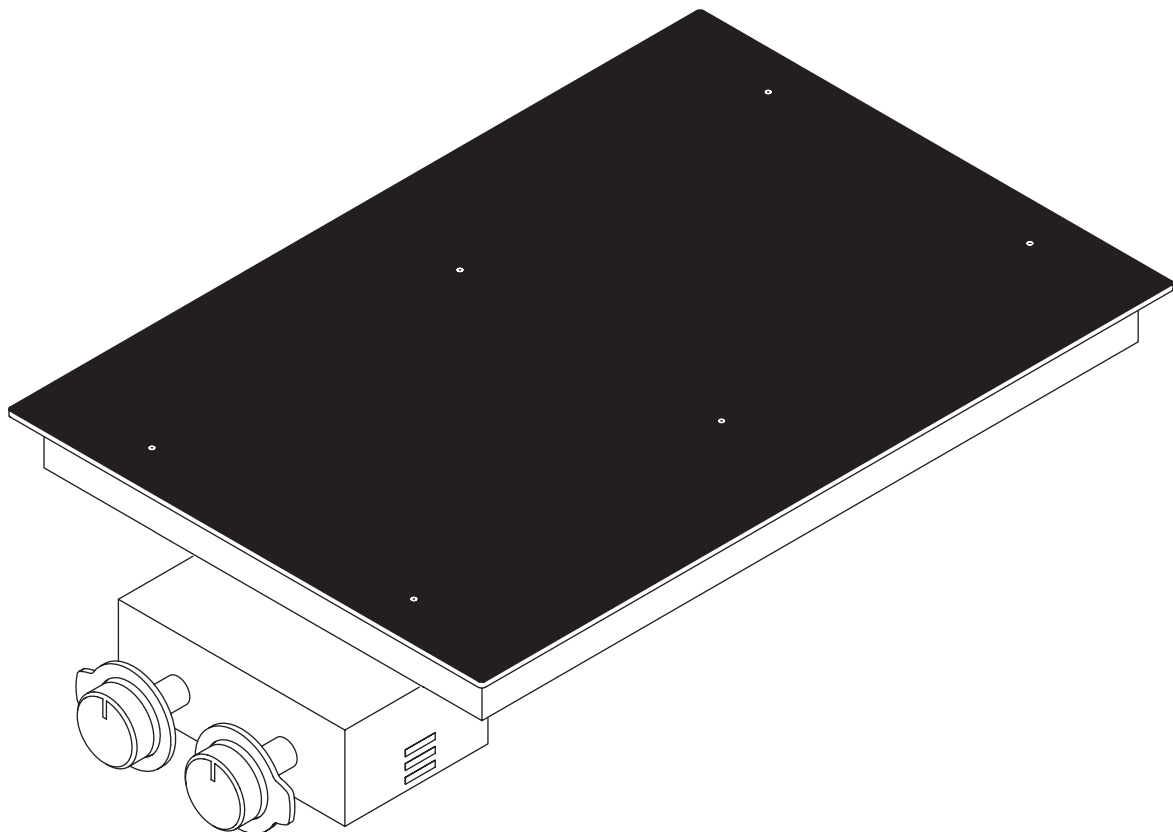

**PFI 1 1UMEN-001**

**Operating and installation instructions:**

Original

Translation

**Manufacturer**

**BORA Lüftungstechnik GmbH**

Rosenheimer Str. 33

83064 Raubling

Germany

**Contact**

T +49 (0) 8035 / 907-240

F +49 (0) 8035 / 907-249

info@bora.com

www.bora.com

The distribution and duplication of this document, as well as the use and disclosure of its contents are prohibited unless expressly authorised.

© BORA Lüftungstechnik GmbH, 2016

All rights reserved.

# Table of Contents

<b>1</b>	<b>General</b>	<b>4</b>	<b>9</b>	<b>Decommissioning, disassembly and disposal</b>	<b>25</b>
<b>2</b>	<b>Safety</b>	<b>6</b>	9.1	Decommissioning.....	25
2.1	General safety precautions .....	6	9.2	Disassembly .....	25
2.2	Safety instructions, operation .....	7	9.3	Disposing of the product in an environmentally friendly way.....	25
2.3	Safety instructions, assembly.....	8			
2.4	Safety instructions, spare parts .....	9			
2.5	Use as intended .....	10			
<b>3</b>	<b>Technical data</b>	<b>11</b>	<b>10</b>	<b>Warranty, service and spare parts</b>	<b>26</b>
<b>4</b>	<b>Device description</b>	<b>12</b>	10.1	Warranty.....	26
4.1	Structure .....	12	10.2	Service .....	26
4.2	Operating panel and operating principle .....	12	10.3	Spare parts.....	26
4.3	Functional principle.....	13			
4.3.1	Power levels .....	13			
4.3.2	power setting .....	13			
4.3.3	Automatic heat up function.....	13			
4.3.4	Heat retention level.....	13			
4.3.5	Bridging function .....	13			
4.3.6	Suitable cookware .....	13			
4.3.7	Pan size recognition .....	14			
4.4	Safety devices .....	14			
4.4.1	Residual heat display.....	14			
4.4.2	Safety shut-down of the cooking zone .....	14			
4.4.3	Cooking zone overheating protection.....	14			
4.4.4	Childproofing feature.....	14			
<b>5</b>	<b>Installation</b>	<b>15</b>			
5.1	Checking the deliverables .....	15			
5.2	Tool and aids.....	15			
5.3	Assembly instructions .....	15			
5.3.1	Safety distances.....	15			
5.4	Cut-out dimensions .....	15			
5.5	Installing the cooktop.....	17			
5.5.1	Installing the control box behind the floor unit fixed front panel.....	17			
5.5.2	Installing the cooktop.....	18			
5.6	Power connection.....	19			
5.7	Handover to user.....	20			
<b>6</b>	<b>Operation</b>	<b>21</b>			
6.1	Switching cooktop on/off .....	21			
6.1.1	Switching on the cooking zone .....	21			
6.1.2	Switching on the power setting.....	21			
6.1.3	Switching the power setting off early.....	21			
6.1.4	Switching off the cooking zone .....	21			
6.1.5	Bridging function .....	21			
6.1.6	Automatic heat up function .....	21			
6.1.7	Heat retention level.....	22			
6.1.8	Switching the childproofing feature on/off .....	22			
<b>7</b>	<b>Cleaning and Maintenance</b>	<b>23</b>			
7.1	Cleaning agents.....	23			
7.2	Maintaining the cooktop .....	23			
7.3	Cleaning the cooktop .....	23			
7.3.1	Cleaning the control knobs .....	23			
<b>8</b>	<b>Troubleshooting</b>	<b>24</b>			

# 1 General

## Target group

These operating and assembly instructions are intended for the following target groups:

Target group	Requirements
Users	The Device may be used by children from the age of 8 as well as by people with limited physical, sensory or mental capabilities or a lack of experience and/or knowledge, provided they are supervised, have been instructed in the safe use of the device and have understood the dangers involved. Children must be supervised. All safety and warning information and handling instructions in the operating manual must be followed.
Ambitious DIYers	Ambitious DIYers may carry out all the necessary carpentry and assembly work themselves providing that they have the necessary skills and knowledge. They must not connect the current and gas themselves.
Assembly expert	The assembly expert must carry out all the necessary carpentry and assembly work taking existing regulations into account. The current and gas connections must be approved for the system in use by a certified electrician or gas engineer before use.
Electrical expert	The electrical connection must only be executed by a certified electrician. He/she also assumes responsibility for the proper electrical installation and commissioning.
Expert gas connection	The gas connection must only be implemented by a certified gas engineer. He/she also assumes responsibility for the proper gas installation and commissioning.

Tab. 1.1 Target groups

<b>INFO</b>	<p>BORA Holding GmbH, BORA Vertriebs GmbH &amp; Co KG, BORA APAC Pty Ltd and BORA Lüftungstechnik GmbH - hereinafter referred to as BORA - shall not assume any liability for damage caused by non-compliance with these documents nor by improper assembly!</p> <p>The electricity and gas connections must be implemented by a certified engineer. Assembly must only take place in compliance with the applicable norms, regulations and laws. All safety and warning information and handling instructions in the operating and assembly instructions must be followed.</p>
-------------	---

## Validity of the operating and assembly instructions

This manual is valid for several versions of the device. For this reason, it is possible that individual features are described in the manual that do not apply to your device.

## Other applicable documents

Additional documents are valid as well as these operating and assembly instructions, and likewise need to be observed.

Please observe all documents included in the scope of delivery.

<b>INFO</b>	BORA cannot assume any liability for damage caused by non-compliance with these documents!
-------------	--

## Guidelines

These devices meet the following EC guidelines:

- 2014/30/EC EMC Directive
- 2014/35/EC Low-Voltage Directive
- 2009/125/EC Ecological Design Directive
- 2011/65/EC RoHS Directive
- 2012/19/EC WEEE Directive

## Depiction of information

We used standard formatting, numbering, symbols, safety instructions, terms and abbreviations so that you can work quickly and safely when using this manual.

**Instructions** are marked with an arrow.

► Always perform all instructions in the prescribed order. **Enumerations** are indicated with a square bullet point at the start of the line.

- Enumeration 1
- Enumeration 2

<b>INFO</b>	Information notes point to special features that must be taken into account.
-------------	--

## Safety and warning instructions

The safety and warning instructions in this manual are emphasised with symbols and signal words.



Safety and warning instructions are structured as follows:

**WARNING SYMBOL AND SIGNAL WORD!**  
**Type and source of the danger**  
 Results of non-compliance

- Measures to minimise risk

Please note:

- The warning symbol draws your attention to the risk.
- The signal word indicates the severity of that risk.

Warning symbol	Signal word	Risk
	<b>Danger</b>	Indicates an immediate, hazardous situation which causes death or serious injury if not respected.
	<b>Warning</b>	Indicates a potentially hazardous situation which can cause death or serious injury if not respected.
	<b>Caution</b>	Indicates a possible hazardous situation which can cause minor injury if not respected.
–	<b>Caution</b>	Indicates a situation which can cause minor injury if not respected.

Tab. 1.2 Meaning of the warning symbols and signal words

## 2 Safety

### 2.1 General safety precautions

---

**INFO** The product complies with the mandatory safety provisions. The user is responsible for cleaning, care and safe use of the device. Any improper use may lead to personal injury and property damage.

---

- This operating and installation instructions contain important information concerning assembly and operation. It protects you from injury and prevents damage to the product. You can find contact data to get further information and answers to questions about the use of the product on the last page of this operating and installation instructions.
- The term “device” is used to refer to cooktop, cooktop extractor or cooktop with integrated cooktop extractor.
- ▶ Read this operating and installation instructions in full before you assemble the device and start to use it.
- ▶ Always keep these operating and installation instructions to hand so it is available when needed.
- ▶ After selling the device, pass on the operating and installation manual to the new owner.
- ▶ Carry out all work with great care and attention.
- ▶ Check the device for visible damage after unpacking.
- ▶ Do not install a damaged device.
- ▶ Do not use the device until installation is complete. Only in this way a safe operation can be guaranteed.
- ▶ Make sure contact with hot cooking surfaces is not possible.
- ▶ Avoid over-cooking.
- ▶ Pay attention to the residual heat indicator.
- ▶ Turn the device off after use.
- ▶ Do not rely on the pan size recognition.
- ▶ Keep pets away from the device.

#### Recirculated air mode

---

**INFO** Every time the device is used for cooking, supplementary moisture is released into the room air.

---



---

**INFO** In the recirculated air mode, only a small amount of moisture is removed from the cooking vapours.

---

- ▶ Make sure that the room is sufficiently ventilated to the outside air in the recirculated air mode, e.g. through an open window.
- ▶ Ensure a normal and comfortable indoor climate (45-60% humidity), e.g. through natural ventilation openings or domestic ventilation systems.
- ▶ Set the cooktop extractor to a low setting for about 15 minutes or activate the automatic after-run after every use in the recirculated air mode.

#### Effects on pacemakers, hearing aids and metal implants

---

**INFO** Induction cooktops generate a high-frequency electromagnetic field in the area of the cooking zones. The cooking zones may affect pacemakers, hearing aids or metal implants negatively or disturb their function when in close proximity. A reduced function of the pacemaker is unlikely.

---

- ▶ If in doubt, contact the manufacturer of your medical device or your doctor.

#### When there are children and people with special needs in the house

- This device may be used by children from the age of 8 as well as by persons with limited physical, sensory or mental capabilities or a lack of experience and/or knowledge, provided they are supervised, have been instructed in the safe use of the device and have understood the dangers involved.
- Do not leave children unattended when they are near the device.
- Children must not play with the device.
- Use the child safety lock in order to prevent children from switching on the cooktop or changing the settings when they are unattended.
- ▶ Do not store any objects that could be of interest to children in storage spaces above or behind the device. Otherwise, the children will be tempted to climb onto the device.
- ▶ Keep children and other persons away from the cooking surfaces.

### Unauthorised modifications

Due to unauthorised modifications  
The device can constitute a hazard.

- ▶ Do not make any changes to the device.

### Cleaning and Maintenance

The device must be cleaned at regular intervals. Dirt can lead to damage or odour nuisance.

Remove dirt immediately.

- Any work involving cleaning and user maintenance must not be carried out by children unless they are supervised at all times while doing so.
- ▶ Do not use a steam cleaner for cleaning. Steam can cause a short circuit on live parts and thus lead to property damage (see the Cleaning chapter).
- ▶ Do not place any hot cookware in the area of the control panel so as not to damage the underlying electronics.
- ▶ When cleaning the device, water must not penetrate the interior of the device. Use only a slightly damp cloth. Never spray the device with water. Water penetration can cause damage!
- ▶ Whenever possible, clean the cooktop after every use.
- ▶ Clean the cooktop only after it has cooled down.
- ▶ When cleaning, only use non-abrasive cleaning agents to prevent scratching and abrasion on the surface.
- ▶ Make sure that the base of the cookware as well as the cooking zone are clean and dry.
- ▶ Always lift (do not drag!) the cookware to prevent scratching and abrasion on the surface.

## 2.2 Safety instructions, operation

### Cooktop



#### **DANGER!** **Danger of fire caused by leaving the cooktop unattended!**

Oil or fat in the pot can quickly heat up and ignite.

- ▶ Never leave oil or fat to heat up unattended.
- ▶ Never extinguish oil and fat fires with water.
- ▶ Suffocate the fire, for example by using a lid.



#### **DANGER!** **Danger of explosion caused by flammable liquids!**

Flammable liquids in the vicinity of the cooktop can explode and cause serious injury.

- ▶ Do not place any flammable liquids in the vicinity of the cooktop.



#### **DANGER!** **Danger of electric shock!**

Cracks, fissures or fractures in the glass ceramic panel can damage the underlying electronics. This can cause an electrical shock.

- ▶ If there are any cracks, fissures or fractures in the glass ceramic, switch the device off immediately.
- ▶ Safely disconnect the device from the mains using miniature or automatic circuit breakers, fuses or contactors.



#### **WARNING!** **Risk of burns caused by a hot cooktop!**

The cooktop and its touchable parts become hot during operation. After turning off the cooking zone, allow it to cool down to less than 60°C first. Touching hot surfaces can lead to serious burns.

- ▶ Do not touch the hot cooktop.
- ▶ Keep children away from the hot cooktop unless they are under constant supervision.



#### **WARNING!** **Danger of fire caused by objects on the cooktop!**

The cooktop and its touchable parts become hot when the cooking zone is switched on and while it is cooling down. Objects on the cooktop can heat up and ignite.

- ▶ Do not leave any objects on the cooktop.



**WARNING!**  
**Risk of burns caused by hot objects!**

The cooktop and its touchable parts become hot when the cooking zone is switched on and while it is cooling down. Objects (pot lid, cooktop extractor cover) on the cooktop become hot very quickly and can lead to serious burns.

- ▶ Do not leave any objects on the cooktop.
- ▶ Use suitable aids (pot cloths, thermal glove).



**WARNING!**  
**Risk of burns caused by hot cookware!**

Handles protruding over the worktops can induce children to grab them.

- ▶ Do not turn the handles on the pots or pans to one side over the worktop.
- ▶ Prevent children from pulling down hot pots and pans.
- ▶ A special stove guard for children (available in specialist shops) reduces the danger.



**WARNING!**  
**Risk of burns!**

Liquids between the cooking zone and base of the pot can scald the skin when steaming up.

- ▶ Make sure that the cooking zone and the base of the pot are always dry.

**CAUTION!**  
**Damage caused by hard and pointed objects!**

Hard and pointed objects may cause damage to the glass ceramic plate of the cooktop.

- ▶ Do not use the cooktop surface as a kitchen worktop.
- ▶ Do not use any hard and pointed objects when working on the cooktop.

**CAUTION!**  
**Damage caused by substances containing sugar and salt!**

Substances containing sugar and salt and juices can damage the cooking zone when they are spilled on its hot surface.

- ▶ Make sure that no food or drinks containing sugar or salt and juices are spilled onto the hot cooking zones.
- ▶ Immediately remove food or drinks containing sugar or salt and juices from the hot cooking zone.

**CAUTION!**  
**Escaping hot liquids!**

Unattended pans can boil over allowing hot liquids to escape.

- ▶ Always keep an eye on pans while cooking.
- ▶ Short cooking sessions must be constantly monitored.

## 2.3 Safety instructions, assembly

Installation and assembly of the device may only be carried out by trained personnel who are familiar with and comply with common national regulations and supplementary regulations of the local utility companies.

Work on electrical parts must only be carried out by trained electrical personnel.

The electrical safety of the device is only guaranteed if it is connected to a properly installed protective conductor system. Make sure that these basic safety precautions have been taken.



## Cooktop



### **DANGER!**

#### **Danger of electric shock!**

Connecting the device incorrectly to the mains poses a risk of electric shock.

- ▶ Make sure that the device has a fixed connection to the mains voltage.
- ▶ Make sure that the device is connected to a properly installed protective conductor system.
- ▶ Make sure that technical equipment is provided to allow for all of the device's poles to be disconnected from the mains with a contact opening width of at least 3 mm (miniature and automatic circuit breakers, fuses, contactors).



### **DANGER!**

#### **Danger of electric shock!**

The connection cable can be damaged if it comes into contact with hot cooking zones. A damaged connection cable can cause a (fatal) electrical shock.

- ▶ Make sure that the connection cable does not come into contact with hot cooking surfaces.
- ▶ Make sure that the connection cable is not caught or damaged.



### **CAUTION!**

#### **Back injury caused by heavy loads!**

When removing and inserting the device, incorrect handling may cause injuries to the limbs and the trunk.

- ▶ Always lift the device out of the packaging with two persons.
- ▶ Always place the device onto the worktop cut-out with two persons.
- ▶ Use suitable aids to prevent damage to the limbs and the trunk.

- ▶ Check the device for visible damages before installing it.
- ▶ Do not install a damaged device.
- A damaged device may put your safety at risk!

Repair and maintenance work may only be carried out by specialists authorised by the manufacturer.

## Safety instructions, disassembly and disposal

Disassembly of the device may only be carried out by trained personnel who are familiar with and comply with common national regulations and supplementary regulations of the local utility companies.

Work on electrical parts may only be carried out by trained electrical personnel.



### **DANGER!**

#### **Danger of electric shock!**

Disconnecting the device incorrectly from the mains poses a risk of electric shock.

- ▶ Safely disconnect the device from the mains using miniature or automatic circuit breakers, fuses or contactors.
- ▶ Use a suitable measuring device to ensure that the device is de-energised.



### **DANGER!**

#### **Risk of suffocation!**

Parts of the packaging (e.g. films, polystyrene) can be fatal to children.

- ▶ Store packaging materials away from the reach of children.
- ▶ Dispose of packaging correctly and promptly.

## 2.4 Safety instructions, spare parts



### **WARNING!**

#### **Risk of injury and damage to property!**

Incorrect parts can lead to injury to persons or damage to device! Modifications, attachment parts or conversions to device can impair safety.

- ▶ Only use original spare parts when carrying out repairs.

## 2.5 Use as intended

The device is solely intended for preparing food in private households.

This device is not designed for:

- use outdoors
- installation in vehicles
- heating the room
- use in non-fixed installation sites (e.g. on ships)
- use with an external timer or separate remote control system.

Not using the device as described in this operating and assembly manual is considered not using the device as intended, as is using it beyond the purpose described here.

BORA shall not assume any liability for damages caused by improper use or incorrect operation.

**All misuse is prohibited!**

---

**INFO** BORA Holding GmbH,  
BORA Vertriebs GmbH & Co KG,  
BORA APAC Pty Ltd and  
BORA Lüftungstechnik GmbH shall  
not assume any liability for damage  
arising from non-adherence to the  
safety and warning instructions.

---

### 3 Technical data

Parameter	Value
Supply voltage	220 - 240 V
Frequency	50/60 Hz
Power consumption	3.7 kW
Fuse protection, minimum	1 x 16 A
Dimensions (width x depth x height)	370 x 540 x 51 mm
Control box dimensions (width x depth x height)	190 x 121 x 71 mm
Weight (incl. accessories/packaging)	9.7 kg
Cooktop	
Power levels	1 - 9, P
Front cooking zone power setting	205 x 230 mm    2100 W 3700 W
Back cooking zone power setting	205 x 230 mm    2100 W 3700 W
Cooktop energy consumption	
Front cooking zone	205 x 230 mm    194.1 (Wh/kg)
Back cooking zone	205 x 230 mm    187.4 (Wh/kg)
Cooking zones bridged	205 x 460 mm    197.6 (Wh/kg)
Total (average)	193.0 (Wh/kg)

Tab. 3.1 Technical data

#### Device dimensions

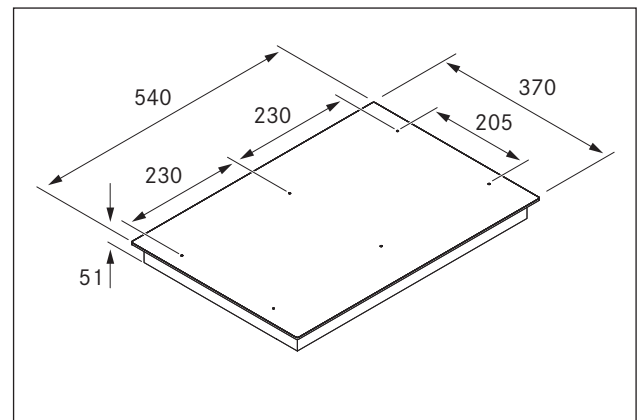

Fig. 3.1 Device dimensions

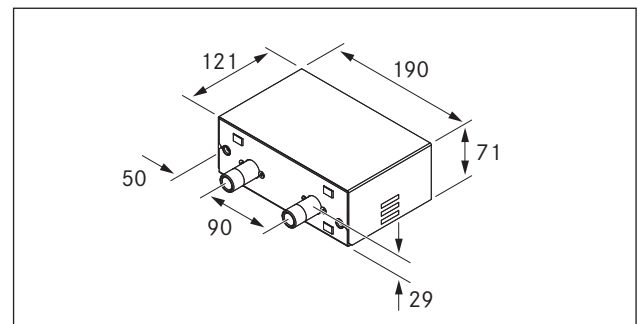

Fig. 3.2 Control box dimensions

## 4 Device description

Observe all safety and warning information during operation (see the Safety section).

The cooktop has the following features:

- Automatic heat up function
- Safety shut-down
- Bridging function
- Electronic power control (9 levels)
- Childproofing feature
- Digital cooking zone indicator
- power setting
- Residual heat display
- Operating indicator light
- Pan size recognition
- Heat retention level

### 4.1 Structure

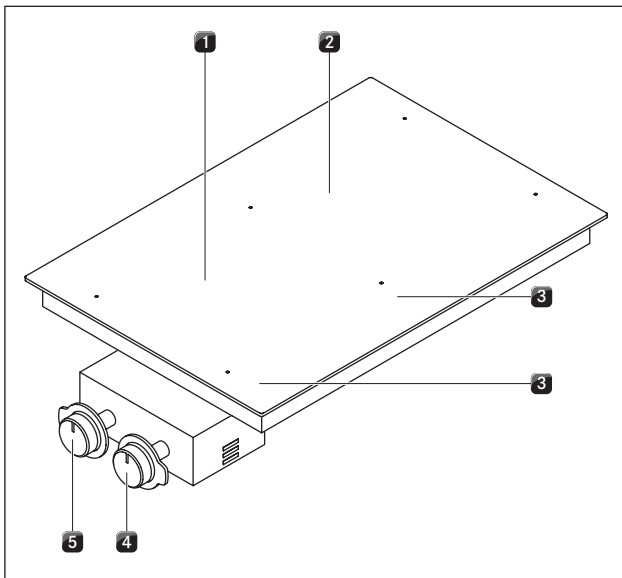

Fig. 4.1 Cooktop

- [1] Front surface induction cooking zone
- [2] Back surface induction cooking zone
- [3] Digital cooking zone indicator
- [4] Control knob for the back cooking zone
- [5] Control knob for the front cooking zone

### 4.2 Operating panel and operating principle

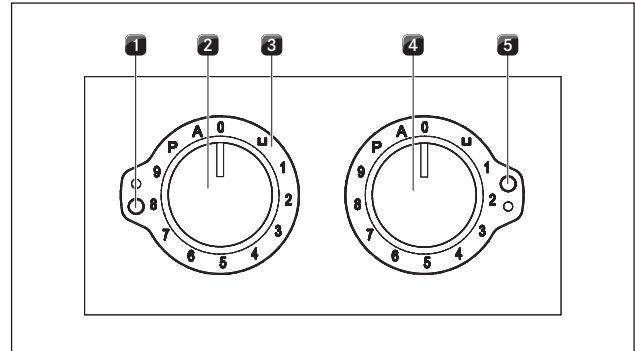

Fig. 4.2 Control knob

- [1] Operating indicator light
- [2] Control knob for the front cooking zone
- [3] Power level sleeve
- [4] Control knob for the back cooking zone
- [5] Operating indicator light

Display field	Display	Meaning
Cooking zone indicator	1 ... 9	Power level
	P	power setting
	A	Automatic heat up function
	L	Child safety lock active
	Π	Bridging function (display only on front cooktop display)
	U	Heat retention level
	u	No cookware or cookware is too small.
	H	Residual heat display: Cooking zone is switched off but still hot (temperature > 60°C)

Tab. 4.1 Display meanings

#### Knob operation

The operating panel is equipped with two control knobs. To operate the appliance, set the relevant control knob to the corresponding power level.

The digital cooking zone indicator shows the cooking zone's function or power level.

#### Operating indicator light

If the indicator light illuminates, the allocated cooking zone is switched on.

## 4.3 Functional principle

An induction coil is located underneath an induction cooking zone. If the cooking zone is switched on, this coil creates a magnetic field that acts directly on the base of the pot thus heating it up. The cooking zone is only indirectly heated up by the heat emitted by the pot. Cooking zones with induction only work if the cookware has a magnetisable base.

The induction automatically takes into account the size of the used cookware which means that only the area in the cooking zone covered by the base of the pot is heated up.

► Observe the minimum pot base diameter.

### 4.3.1 Power levels

The high power output of induction cooktops results in the very quick heating up of cookware. A slight adjustment is needed in comparison to conventional cooking systems when selecting the power level in order to avoid burning food.

Activity	Power level
Keeping cooked food warm at approx. 75°C	u
Melting of butter and chocolate, breaking up gelatine	1
Keeping sauces and soups warm, soaking rice	1-3
Cooking potatoes, pasta, soups, ragouts, steaming fruit, vegetables and fish, defrosting food	2-6
Frying in coated pans, moderate frying (without overheating the fat) of pork cutlets, fish	6-7
Heating up fat, browning fish, cooking thickened sources and soups, making omelettes	7-8
Cooking large quantities of liquid, browning steaks	9
Heating up water	P

Tab. 4.2 Recommendations for power levels

The specifications provided in the table are standard values.

Depending on the cookware and filling quantity, it is recommended to either decrease or increase the power level.

### 4.3.2 power setting

The two cooking zones are equipped with a power-enhancing power setting.

The power setting can be used in order to quickly heat up large quantities of water. If the power setting is activated, the cooking zones will run at extra high power. After 10 minutes, the cooking zone is automatically switched to power level 9.

If the bridging function is activated, the power setting cannot be used.

**INFO** Never heat up oil, fat and the like at this power setting. The bottom of the pan can overheat due to the high power output.

### 4.3.3 Automatic heat up function

The two cooking zones are equipped with an automatic heat up function that can be switched on and off.

■ The display shows P.

This function enables the cooking zone to work at full power for a certain duration after switching on. After this time, the power level is automatically switched back to the power level set.

Power level	1	2	3	4	5	6	7	8
Cooking duration in min:sec	00:40	01:00	02:00	03:00	04:20	07:00	02:00	03:00

Tab. 4.3 Overview of the automatic heat up function

### 4.3.4 Heat retention level

The heat retention level keeps cooked foods warm at approx. 75°C.

■ u is displayed in the cooking zone indicator.

■ The maximum duration for the warming function is limited to 2 hours.

### 4.3.5 Bridging function

The two cooking zones can be operated as a connected cooking zone at the same power level.

■ P appears on the display.

The bridging function is suitable for heating food in a roaster.

### 4.3.6 Suitable cookware

**INFO** The heating and heat through time for the base of the cookware as well as the cooking results are significantly influenced by the structure and material of the cookware.



Cookware with this symbol is suitable for induction cooktops.

The cookware used for the induction cooktop must be made of metal, feature magnetic properties and possess a sufficient bottom surface.

Suitable cookware is made of:

■ stainless steel with a magnetisable base

■ enamelled steel

■ cast iron

Cooking zone	Minimum diameter
Front	120 mm
Back	120 mm

Tab. 4.4 Minimum cookware diameter

- ▶ Perform a magnet test, if necessary. If a magnet sticks to the base of the utensils, they are normally induction compatible.
- ▶ Pay attention to the cookware bottom. The base of the cookware should not show any sign of curvature. Due to incorrect temperature monitoring of the hob caused by the air gap between the cookware and the temperature sensor underneath the hob, overheating may occur. The bottom of the cookware must not have any sharp grooves or sharp edges to avoid scratching the cooktop.
- ▶ Place the cookware (without a mat or similar) directly onto the glass ceramic.

## Noises

The following noises may occur in the cookware when using induction cooking zones, depending on the material and the finish of the base:

- **Humming** may occur when using a high power level. It decreases or disappears if the power level is decreased.
- **Crackling or whistling** may occur due to the bases of cookware made of different materials (e.g. sandwich base).
- **Clicking sounds** may occur during electronic switching procedures especially at low power levels.
- **Whirring** may occur when the cooling fan is switched on. In order to increase the service life of the electronic system, the cooktop is equipped with a cooling fan. The cooling fan switches on automatically if the cooktop is used intensively. You will hear a whirring sound. The cooling fan may continue running after the device has been switched off.

### 4.3.7 Pan size recognition

The cooking zone does not work

- $\sqcup$  is shown in the display.
- If it is switched on without cookware or with unsuitable cookware.
- If the base diameter of the cookware is too small.
- If the cookware is removed from a cooking zone that is switched on.
- If the cooking zone does not detect a pot for 10 minutes, it switches off automatically and can only be switched back on after the control knob has been turned back to the zero position.

## 4.4 Safety devices

### 4.4.1 Residual heat display

---

**INFO** While *H* is displayed in the cooking zone indicator (residual heat display), do not touch the cooking zone or place any heat-sensitive objects on top of it. Risk of burns and fire!

---

After switching it off, the cooking zone remains hot. *H* is displayed in the cooking zone indicator (residual heat

display). The cooking zone indicator will go out after sufficient cooling time (temperature < 60 °C).

### 4.4.2 Safety shut-down of the cooking zone

Each cooking zone is switched off automatically when the cooking zone in the power level exceeds the maximum operating duration. The cooking zone indicator then alternates between displaying *H* (residual heat display) and  $\sqcup$ .

Power level	$\sqcup$	1	2	3	4	5	6
Switch off after	02:00	08:40	06:45	05:15	04:20	03:30	02:45
hours:minutes							

Power level	7	8	9
Switch off after	02:20	01:45	01:30
hours:minutes			

Tab. 4.5 Overview of the safety shut-down

- ▶ Switch the cooking zone back on (see Operating control) if you want to put the cooking zone back into operation.

### 4.4.3 Cooking zone overheating protection

All induction coils plus the cooling elements of the electronics are equipped with overheating protection. Before the induction coils and/or cooling elements overheat, the overheating protection will initiate one of the following measures:

- The power setting  $P$  automatically switches to power level  $9$  after 10 minutes. The cooking zone indicator  $P$  switches to  $9$ .
- The set power level is reduced.
- The cooking zones switch off automatically (see safety shut-down of the cooking zones).

### 4.4.4 Childproofing feature

The childproofing feature prevents the cooktop from being switched on accidentally. The childproofing feature can only be activated when the cooktop is switched on and all cooking zones are switched off (see the Operation chapter).

## 5 Installation

- ▶ Observe all safety and warning information (see the Safety chapter).
- ▶ Follow the enclosed manufacturer's information.

**INFO** The cooktop must not be installed above cooling devices, dishwashers, stoves, baking ovens, washing machines or driers.

**INFO** The contact surface of the worktops and wall sealing strips must be made of a heat-resistant material (up to approx. 100 °C).

**INFO** Worktop cut-outs must be moisture-sealed using suitable means or, where necessary, fitted with a thermal insulator.

### 5.1 Checking the deliverables

Name	Quantity
Control box adjustment plates	6
Control knobs	2
Operating and installation instructions	1
Fixing nuts	2
Cooktop mounting screws	4
Control box fixing screws	2
Drilling template	1
Height adjustment plate set	1
Allen key	1
Cooktop	1
Power level sleeve	2
Mounting bracket	1
Cooktop mounting straps	4
Cleaning instructions for glass ceramic	1
Glass ceramic scraper	1

Tab. 5.1 Scope of delivery

- ▶ Check the scope of delivery for damage and make sure it is complete.
- ▶ If there are any missing or damaged parts, please notify BORA After Sales Service immediately.
- ▶ Do not under any circumstances install parts which are damaged.
- ▶ Dispose of transport packaging in the proper manner (see the Decommissioning and Disposal chapter).

### 5.2 Tool and aids

The following tools are required for the correct installation of the cooktop:

- Pencil
- Drill or cordless drill with Forstner bit Ø 30 mm
- Drilling template (included in scope of delivery)
- Phillips screwdriver Z2
- Silicone sealant for sealing cutting surfaces

### 5.3 Assembly instructions

#### 5.3.1 Safety distances

- ▶ Maintain the following safety distances:

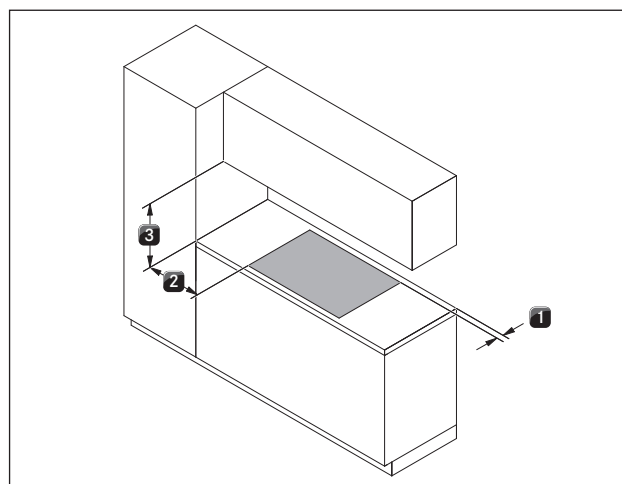

Fig. 5.1 Minimum distance

- [1] Minimum distance of 50 mm at the back from of the worktop cut-out to the rear edge of the worktop.
- [2] Minimum distance of 50 mm from the left and right of the worktop cut-out to the adjacent cabinet or wall. For ergonomic reasons and to ensure efficient cooktop extraction, a minimum distance of 300 mm is recommended.
- [3] Minimum distance of 700 mm between the worktop and the wall unit. A minimum distance of 1000 mm is recommended for ergonomic reasons.

### 5.4 Cut-out dimensions

#### Preparing the worktop

- ▶ Create the worktop cut-out taking into account the specified cut-out dimensions.
- ▶ Make sure that the cutting surfaces of the worktops are properly sealed.
- ▶ Comply with the instructions of the worktop manufacturer.

**Worktop overhang**

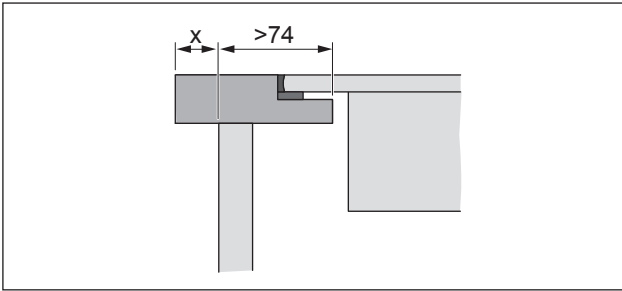

Fig. 5.2 Worktop overhang

► Please note the worktop overhang x when creating the worktop cut-out. Applies to both flush installation and surface mounting.

**Flush installation**

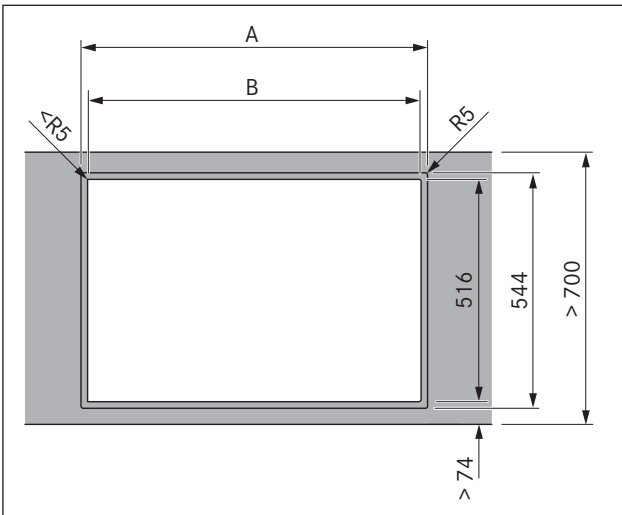

Fig. 5.3 Flush installation

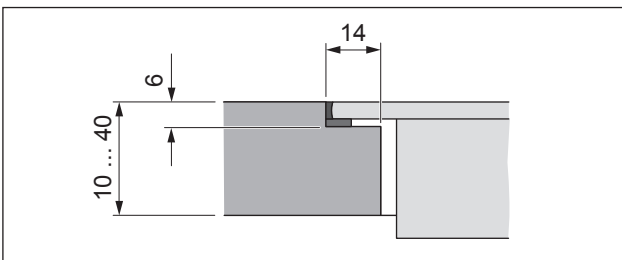

Fig. 5.4 Dimension of groove for flush installation

**INFO** If the induction glass ceramic wok is used, the groove dimensions must be increased to 7 mm for flush installation.

**Surface installation**

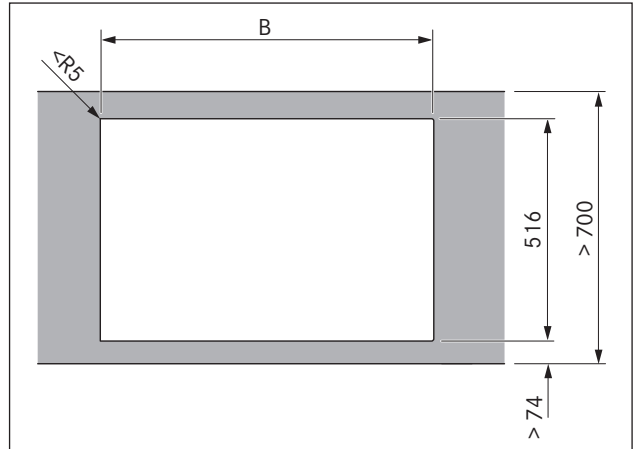

Fig. 5.5 Surface installation

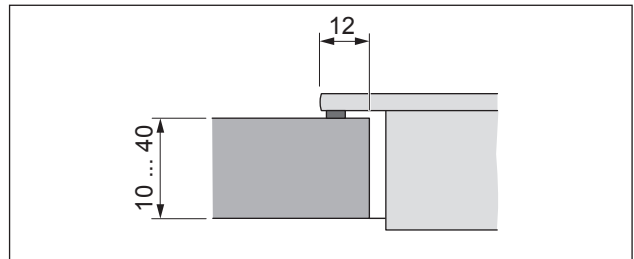





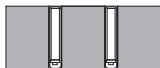



Fig. 5.6 Surface mounting cut

Cut-out dimensions when installing cooktops or cooktops and the cooktop extractor next to each other:

Cooktops / cooktop extractor	A in mm	B in mm	
	1/0	374	346
	2/0	745	717
	3/0	1116	1088
	1/1	485	457
	2/1	856	828
	3/2	1338	1310
	4/2	1709	1681

Tab. 5.2 Cut-out dimensions



## 5.5 Installing the cooktop

**INFO** A gap of one millimetre should be planned between the built-in appliances.

**INFO** A gap of two millimetres should be planned around the built-in appliances.

**INFO** The mounting rail supplied with the cooktop should be installed between the cooktops as well as between the cooktops and the cooktop extractor.

**INFO** Cable protection (a false floor) should be mounted below the appliance. This needs to be removable for maintenance work.

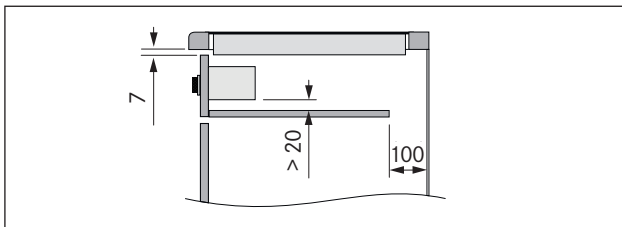

Fig. 5.7 Side view of the cable protection and ventilation

- Cross bars on the kitchen unit in the area of the worktop cut-out may need to be removed.
- The drawers and/or shelves in the floor unit must be removable for maintenance and cleaning purposes.
- Make sure that the area below the cooktop is sufficiently ventilated. An opening cross-section  $> 50 \text{ cm}^2$  at the front side and in the false floor for the ventilation of the induction equipment should be available.

### 5.5.1 Installing the control box behind the floor unit fixed front panel

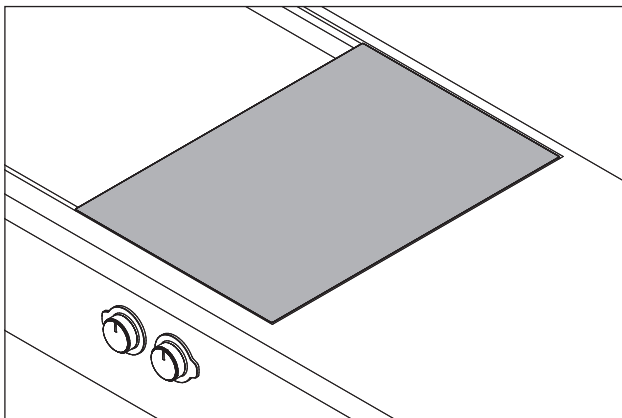

Fig. 5.8 Installed control box and cooktop

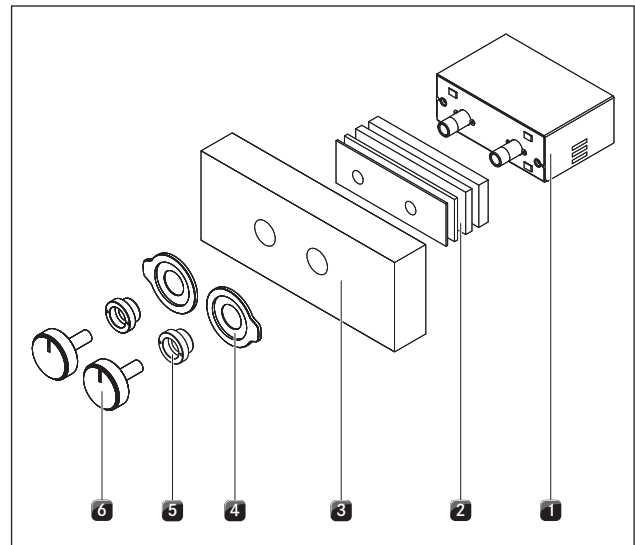

Fig. 5.9 Control box structure

- [1] Control box
- [2] Adjustment plates
- [3] Fixed front panel (not included in scope of delivery)
- [4] Power level sleeve
- [5] Nuts
- [6] Control knobs

- Draw the bore holes accordingly with the aid of the drilling template provided.

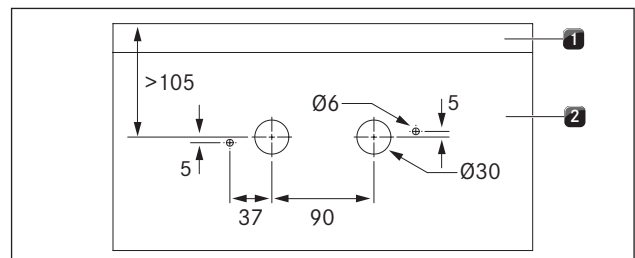

Fig. 5.10 Drilling template

- [1] Worktop
- [2] Fixed front panel

- Pre-drill the bore holes to prevent tearing out the fixed front panel.

#### Determine the number of adjustment plates

- The total dimensions of the adjustment plates [2] and the fixed front panel [3] should be 36 mm.
- The total dimensions of 36 mm must be adhered to in order to ensure that the control box [1] functions smoothly.

Panel thickness [mm]	Total thickness of adjustment plates [mm]	Adjustment plates [quantity]			
		10 mm	5 mm	3 mm	2 mm
34	2	-	-	-	1
33	3	-	-	1	-
32	4	-	-	-	2
31	5	-	-	1	1
30	6	-	-	2	-
29	7	-	1	-	1
28	8	-	1	1	-
27	9	-	1	-	2
26	10	1	-	-	-
25	11	-	1	2	-
24	12	1	-	-	1
23	13	1	-	1	-
22	14	1	-	-	2
21	15	1	1	-	-
20	16	1	-	2	-
19	17	1	1	-	1
18	18	1	1	1	-
17	19	1	1	-	2
16	20	1	1	1	1
15	21	1	1	2	-
14	22	1	1	1	2
13	23	1	1	2	1

Tab. 5.3 Adjustment plate overview

### Secure the control box

- ▶ Position the control box [1] with the attached adjustment plates [2] from the back into the bore holes in the fixed front panel.
- ▶ Attach the two power level sleeves [4] to the front of the fixed front panel.

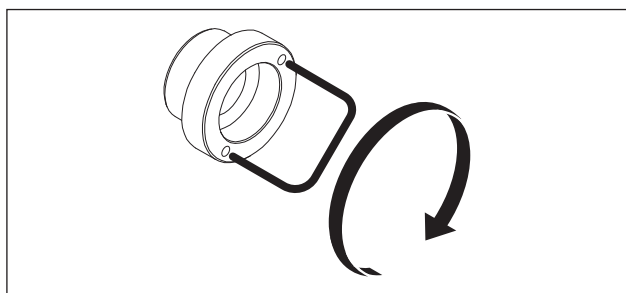

Fig. 5.11 Tighten the fixing nuts

- ▶ Screw on the fixing nuts [5] with the mounting bracket and tighten the fixing nuts with max. 10 Nm.
- ▶ Insert the lens from the front into the power level sleeve.
- ▶ Put on the control knob [6].

### Adjust the control knob

For fine adjustment, the distance between the control knob and the power level sleeve can be set.

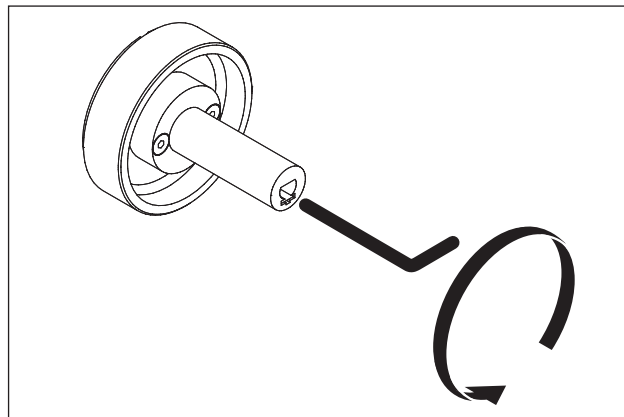

Fig. 5.12 Position control knob

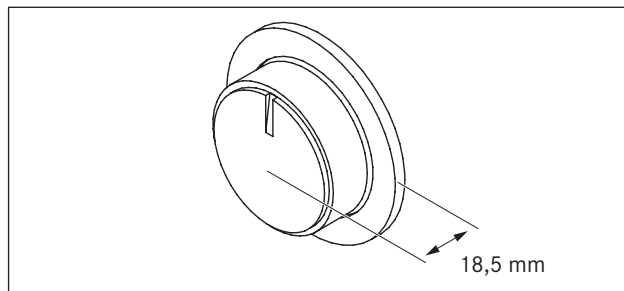

Fig. 5.13 Distance of the control knob

### 5.5.2 Installing the cooktop

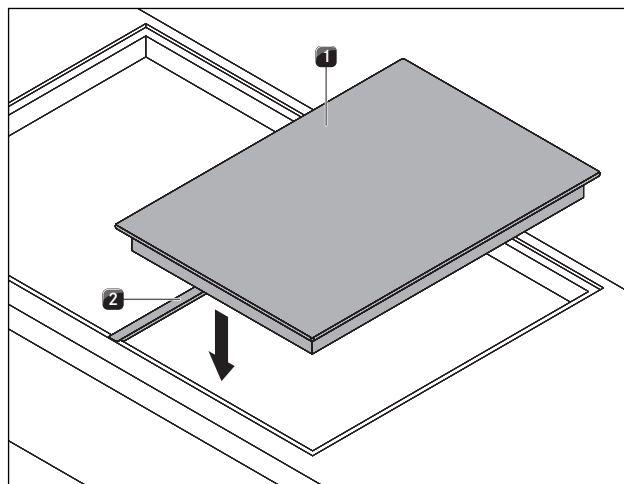

Fig. 5.14 Insert the mounting rail and cooktop

- [1] Cooktop
- [2] Mounting rail

- ▶ Place the mounting rail [2] in the worktop cut-out.
- ▶ Insert the cooktop [1].
- ▶ Align the cooktop [1] exactly.
- ▶ Align the mounting rail [2] so that it is positioned evenly under the cooktop and the cooktop extractor PL540.

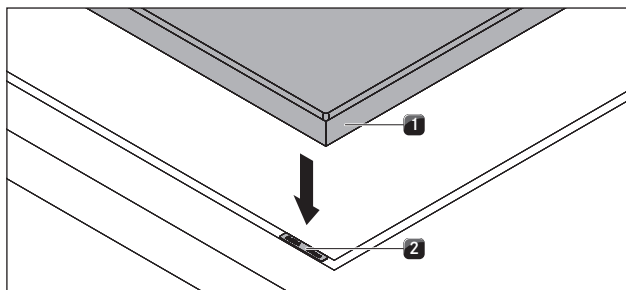

Fig. 5.15 Cooktop and height adjustment plates

- [1] Cooktop  
[2] Height adjustment plates

- If applicable, insert the height adjustment plate [2].



Fig. 5.16 Mounting brackets

- [1] Screw  
[1] Mounting bracket

- Fasten the cooktop [1] using the mounting brackets [2].  
► Tighten the mounting bracket screws [1] with max. 10 Nm.  
► Verify that the alignment is correct.  
► Seal the devices with black heat-resistant silicone sealing compound after the installation work is completed.

## Connecting the cooktop and the control box

- Create the connection between the cooktop and the control box.  
► Firstly connect the yellow/green earthing cable to the indicated point on the control box.



Earthing symbol

- Now connect the multi-pin, colour-coded plugs on the relevant cooking zone to the corresponding colour-coded sockets on the control box.

## 5.6 Power connection

- Observe all safety and warning information (see the Safety chapter).  
► Observe all national and regional laws and regulations as well as the supplementary regulations of the local utility companies.

**INFO** The power connection may only be established by a certified specialist. He/she also assumes responsibility for the proper installation and commissioning.

The power supply line for use (pre-assembled) must be at least Type H05VV-F or H05VVH2-F.

- Cross-section: 3G1.5 mm<sup>2</sup> with 1-phase connection
- If the connection line has been damaged this must be replaced by a special connection line. This may only be done by an authorized member of the After Sales Service team.

### Establishing the power connection

- Switch off the main switch/automatic circuit breaker before connecting the cooktop.  
► Protect the main switch/automatic circuit breaker from being switched on without permission.  
► Make sure the device is not energised.  
► Only connect the cooktop using a permanent connection to a power supply cable.

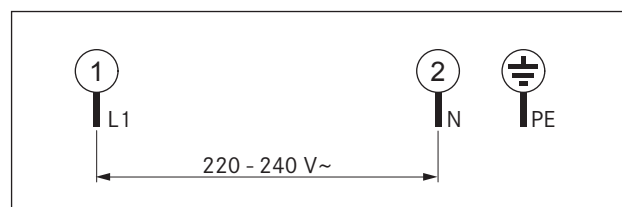

Fig. 5.17 Connection diagram 1-phase

- Create the connection between the cooktop and the control box.  
► Verify that the installation was done correctly.  
► Switch on the main switch/automatic circuit breaker.  
► Put the cooktop into operation (see the Operation section).  
► Check all the functions are working correctly.

## 5.7 Handover to user

Once installation is done:

- ▶ Explain the important functions to the user.
- ▶ Explain all safety-relevant aspects of operation and handling to the user.
- ▶ Provide the user with the accessories and operating and installation instructions to be kept in a safe place.

## 6 Operation

- ▶ Observe all safety and warning information during operation (see the Safety section).

---

**INFO** The cooktop may only be operated when the stainless steel grease filter of the cooktop extractor is installed (see operating instructions for cooktop extractor).

---

**INFO** Clean the cooking zone before using the cooktop for the first time (see the Cleaning chapter).

---

### 6.1 Switching cooktop on/off

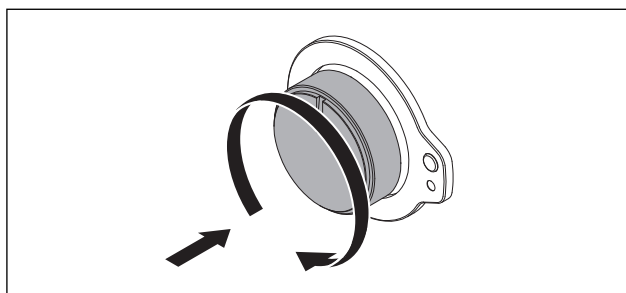

Fig. 6.1 Push and pull control knob

#### 6.1.1 Switching on the cooking zone

- ▶ Push and turn the control knob to power level  $I$  to switch on the cooking zone.
- The operating indicator light is active.

#### Adjusting the power level

- ▶ Turn the control knob to the desired power level.

#### 6.1.2 Switching on the power setting

---

**INFO** Both cooking zones are equipped with a power-enhancing power setting.

---

If a cooking zone is operated at power setting  $P$ , the other cooking zones can be operated at a maximum power level of  $S$ .

If the power setting is increased to  $S$ , the power level will switch back to  $P$ .

- ▶ Press and turn the control knob past power level  $G$  until the power setting  $P$  is shown on the cooking zone indicator.
- After 10 minutes, the cooking zone is automatically switched back to power level  $G$ .

#### 6.1.3 Switching the power setting off early

- ▶ Turn the control knob past power level  $G$  again.
- Power level  $G$  is active and is shown in the cooking zone indicator.

or

- ▶ Turn the control knob to the desired power level.
- The power level set is active and is shown in the cooking zone indicator.

#### 6.1.4 Switching off the cooking zone

---

**INFO** If a cooking zone indicator shows  $H$ , the cooking zone is still hot.

---

**INFO** Turn the cooking zone off after use. Do not rely on the pan size recognition.

---

- ▶ Turn the control knob to power level  $0$  to switch off the cooking zone.
- The operating indicator light is inactive.
- The cooktop is switched off when there are no longer any active cooking zones.
- ▶ Pay attention to the residual heat display (see the Device Description chapter).

#### 6.1.5 Bridging function

- If the bridging function is active, both cooking zones will operate at the same time on the same cooking zone.
- If the bridging function is activated, the power setting  $P$  cannot be used.

#### Switching on the bridging function

- ▶ Press and simultaneously turn both control knobs to the left to the symbol  $A$ .
- ▶ Release both control knobs.
- ▶ Then turn the left control knob again to power level  $G$ .
- ▶ Set the desired power level with the right control knob.
- The bridge symbol  $A$  appears in the front cooking zone indicator.
- The selected power level (for both cooking zones) appears in the rear cooking zone indicator.
- The power levels of both cooking zones can now be regulated at the same time with the right control knob.

#### Switching off the bridging function

- ▶ Turn both control knobs to power level  $0$ ; the bridging function and the cooktop are switched off.

#### 6.1.6 Automatic heat up function

##### Switching on the automatic heat up function

- ▶ Press and turn the control knob for the desired cooking zone to the left to the symbol  $A$ .
- ▶ Within 5 seconds, select the desired power level (continuous cooking stage), which should be used to continue the cooking session after the end of the automatic heat up function.
- The cooking zone indicator will display the symbol  $A$  to show that the automatic heat up function is activated as well as the continuous cooking stage set, for example  $S$ .

- An  $\overline{H}$  will be displayed in the cooking zone indicator while the automatic heat up function is active.
- Once the automatic heat up period has passed, the power will be reduced to the selected continuous cooking stage.
- If a higher continuous cooking stage is selected while the automatic heat up function is active, the new time will automatically be valid.

### Switching off the automatic heat up function

The activated automatic heat up function will end prematurely if you

- ▶ reduce the power level (continuous cooking stage).
- ▶ set power level  $\overline{9}$ .
- ▶ activate the power setting  $\overline{P}$ .
- ▶ activate the heat retention level  $\cup$ .
- ▶ switch off the cooktop.

#### 6.1.7 Heat retention level

- ▶ Press and turn the control knob of the desired cooking zone to the heat retention level  $\cup$  to activate it.
- The heat retention symbol  $\cup$  is displayed in the respective cooking zone indicator.
- The cooking zone will automatically switch off after 2 seconds.

#### 6.1.8 Switching the childproofing feature on/off

---

**INFO** If a cooking zone indicator alternates between displaying  $L$  and  $H$ , the cooking zone is still hot.

---

#### Switching on the childproofing feature

**Prerequisites:**

- The cooktop is switched off.
  - ▶ Press the left or right control knob of the relevant cooking zone.
  - ▶ Turn the control knob to the left, holding it at position  $\overline{H}$  for at least 5 seconds.
- or
- ▶ Press both control knobs of the relevant cooking zone.
  - ▶ Turn both control knobs to the left for at least 5 seconds to the position  $\overline{H}$ .
  - Both cooking zone indicators will display  $L$ .  
The childproofing feature is activated.

#### Switching off the childproofing feature

- ▶ Press the left or right control knob of the relevant cooking zone.
  - ▶ Turn the control knob to the left, holding it at position  $\overline{H}$  for at least 5 seconds.
- or
- ▶ Press both control knobs of the relevant cooking zone.
  - ▶ Turn both control knobs to the left for at least 5 seconds to the position  $\overline{H}$ .
  - Both cooking zone indicators go out.
  - The child safety lock is deactivated.

## 7 Cleaning and Maintenance

- ▶ Observe all safety and warning information (see the Safety chapter).
- ▶ Follow the enclosed manufacturer's information.
- ▶ Make sure that the cooktop and cooktop extractor have been switched off completely and have cooled down prior to the planned cleaning and maintenance work to prevent injury (see the Operation chapter).
- Regular cleaning ensures the longevity of the product and optimal functioning.
- ▶ Adhere to the following cleaning and maintenance cycles:

Component	Cleaning cycle
Control knob	immediately after every soiling
Cooktop	immediately after every soiling every week thoroughly with standard commercially available cleaning agents

Tab. 7.1 Cleaning cycles

### 7.1 Cleaning agents

**INFO** Due to the use of aggressive cleaning agents and abrasion caused by the pot bases the surface will become damaged and dark stains will occur.

You need a special glass ceramic scraper and suitable cleaning agents to clean the cooktop.

- ▶ Never use steam cleaners, abrasive sponges, scouring pads, or chemically aggressive cleaning agents (e.g. baking oven spray).
- ▶ Make sure that the cleaning agent does not contain any sand, soda, acids or chloride.

### 7.2 Maintaining the cooktop

- ▶ Do not use the cooktop as a worktop or shelf.
- ▶ Do not push or pull cookware across the cooktop.
- ▶ Always lift pots and pans.
- ▶ Keep the cooktop clean.
- ▶ Remove any kind of soiling immediately.
- ▶ Only use cookware which is suitable for glass ceramic cooktops (see the Device description chapter).

### 7.3 Cleaning the cooktop

**INFO** When the cooktop extractor is switched on, the stainless steel grease filter must be installed to ensure that no small and light objects, such as cleaning wipes made of fabrics or paper are sucked in (see operating instructions for the cooktop).

- ▶ Make sure that the cooktop is switched off (see the Operating chapter).
- ▶ Wait until all cooking zones are cold.
- ▶ Remove all coarse soiling and food residues from the cooktop with a glass ceramic scraper.
- ▶ Apply the cleaning agent onto the cold cooktop.
- ▶ Rub the cleaning agent with a paper towel or a clean cloth.
- ▶ Wipe off the cooktop while wet.
- ▶ Rub the cooktop dry with a clean cloth.

#### When the cooktop is hot:

- ▶ Immediately remove molten residues of plastic, aluminium film, sugar or foods containing sugar with a glass ceramic scraper from the hot cooking zone to prevent burning them in.

#### Heavy soiling

- ▶ Remove heavy soiling and stains (limescale stains, pearly shimmering stains) with cleaning agents while the cooktop is still warm.
- ▶ Soften dried dirt residues using a damp cloth.
- ▶ Remove dirt residues with the glass ceramic scraper.
- ▶ Always remove grains, crumbs or similar which fall onto the cooktop during general cooking work right away to prevent the surface from being scratched.

Coloured changes and shiny surfaces are not cooktop damage. They do not impact on the function of the cooktop and the stability of the glass ceramic. Discolourations to the cooktop arise from residues which are not removed and have been burnt in. Glossy spots are caused by the abrasion of the pot base, especially when using cooking utensils with aluminium bases, or by unsuitable cleaning agents. They are very hard to remove.

#### 7.3.1 Cleaning the control knobs

- ▶ Ensure that the cooktop is switched off (see the Operating chapter).
- ▶ Clean only the control knob by hand.
- ▶ Pull off the control knob.
- ▶ Clean the control knob with a soft brush.
- ▶ Rinse the control knob well after cleaning.
- ▶ Allow the control knob to dry thoroughly.
- ▶ Re-insert the clean and dry control knob into the slot after the cleaning is completed.

## 8 Troubleshooting

Observe all safety and warning information (see the Safety chapter).

Operating situation	Cause	Remedy
The cooktop cannot be switched on.	The fuse or the automatic circuit breaker of the electrical installation of the apartment and/or house is defective.	Replace the fuse. Switch the safety cut-out back on.
	The fuse or the automatic circuit breaker trips several times.	Call the BORA Service Team.
	The power supply is disconnected.	Have a specialist electrician inspect the power supply.
Odours and vapours arise when the new cooktop is put into operation.	This is normal on brand-new appliances.	Wait a few operating hours. Contact the BORA Service Team if the odour persists.
$\underline{u}$ is displayed in the cooking zone indicator.	No or unsuitable cookware has been placed on the cooking zone.	Only use suitable cookware. Select the cookware size depending on the cooking zone (see the Device Description chapter).
$\underline{L}$ is displayed in the cooking zone indicator.	The child safety lock is activated.	Switch off the childproofing feature (see the Operation chapter).
$\curvearrowright$ is displayed in the cooking zone indicator.	Permanent activation of a knob.	Put the knob back into position.
	Cable break between cooktop and control box.	Call the BORA Service Team.
$\underline{E}$ is displayed in the cooking zone indicator.	The associated cooking zone or a power element is defective.	Note down the error number and contact the BORA Service Team.
A cooking zone or the entire cooktop switches off automatically.	The operating time of a cooking zone has been exceeded.	Put the cooking zone back into operation (see the Operation chapter). (see the Device Description chapter)
	The overheat protection has tripped.	(see the Device Description chapter)
The power setting is automatically shut off prematurely.	The overheat protection has tripped.	(see the Device Description chapter)
The cooling fan continues running after the cooktop has been switched off.	The fan will continue to run until the cooktop has cooled down and will then switch off automatically.	Wait until the fan switches off automatically.

Tab. 8.1 Resolving a fault

► In all other instances, call the BORA Service Team (see the Warranty, service and spare parts chapter).



## 9 Decommissioning, disassembly and disposal

- ▶ Observe all safety and warning information (see Safety chapter).
- ▶ Follow the enclosed manufacturer's information.

### 9.1 Decommissioning

Decommissioning is considered the final decommissioning and disassembly. After decommissioning, the device can either be built into another piece of furniture, sold on privately, or disposed of.

---

**INFO** Disconnecting and connecting the electricity and gas connection may only be carried out by certified experts.

---

- ▶ Switch off the device before decommissioning (see Operating chapter)
- ▶ Disconnect the device from the voltage supply.

### 9.2 Disassembly

The removal requires that the device is accessible for disassembly and was separated from the voltage supply. On gas-powered devices, make sure that the gas connection is complete.

- ▶ Undo the mounting brackets.
- ▶ Remove the silicone joints.
- ▶ Remove the device from the worktop upwards.
- ▶ Remove further accessory parts.
- ▶ Remove the old appliance and dirty accessory as described under "Disposing of the product in an environmentally friendly way".

### 9.3 Disposing of the product in an environmentally friendly way

#### Disposal of transport packaging

---

**INFO** The packaging protects the device against transport damages. The packaging is made of materials that are environmentally friendly and easy to dispose of and can therefore be recycled.

---

Returning the packaging material into the material cycle saves resources and reduces the waste production. Your specialist supplier will take the packaging back.

- ▶ Hand the packaging to your specialist supplier or
- ▶ Dispose of the packaging properly taking into account the regional regulations.

#### Disposing of the old appliance



Electrical devices marked with this symbol should not be disposed of as household waste at the end of its life. They must be taken to a collection centre for recycling electrical or electronic non-heating appliances. For information, please contact your city or local authorities.

Waste electric and electronic equipment often still contains valuable materials. They do, however, also contain harmful substances that were required for their correct functioning and safety. When disposed of in the residual waste or if not handled correctly, they may cause harm to the health of people and the environment.

- ▶ Therefore do not dispose of your old appliance as household waste.
- ▶ Take the old appliance to a regional collection centre for return and recycling of electronic and electrical parts and other materials.

## 10 Warranty, service and spare parts

- ▶ Observe all safety and warning information (see Safety chapter).

### 10.1 Warranty

The warranty period shall be 2 years.

### 10.2 Service

#### **BORA Service:**

see reverse side of operating and assembly instructions



- ▶ In the case of faults you cannot fix yourself, contact your BORA specialist supplier or the BORA Service Team.

The After Sales Service will require the type designation and the serial number of your device (FD number). This information is provided on the nameplate or on the back of the manual as well as on the device.

### 10.3 Spare parts

- ▶ Only use original spare parts when making repairs.

---

**INFO** Spare parts can be obtained from your BORA dealer, the BORA online service website at [www.bora.com/service](http://www.bora.com/service) or by calling the service number provided.

---



**Nameplate:**

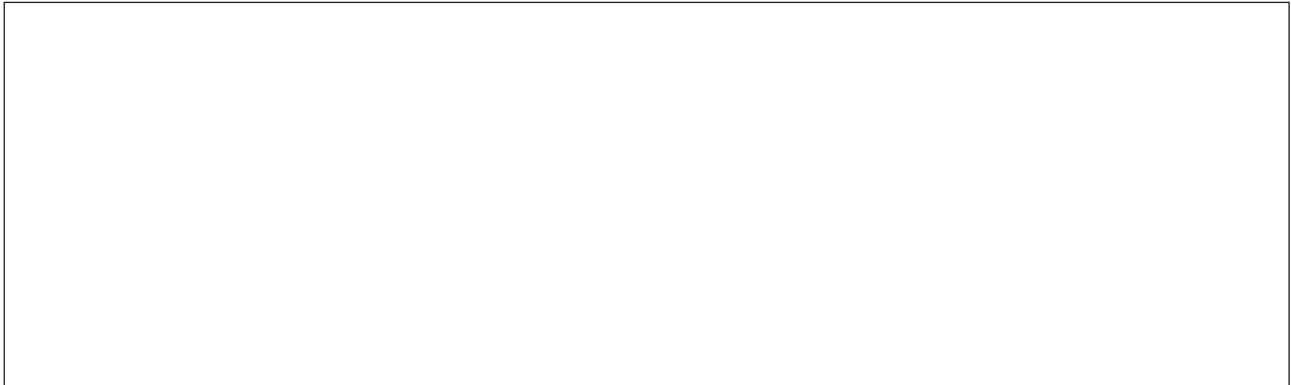

**Germany::**

**BORA Lüftungstechnik GmbH**  
Rosenheimer Str. 33  
83064 Raubling  
Germany  
T +49 (0) 8035 / 907-240  
F +49 (0) 8035 / 907-249  
info@bora.com  
www.bora.com

**Australia – New Zealand:**

**BORA APAC Pty Ltd**  
A/ 91-95 Victoria Road  
Drummoyne NSW 2047  
Australia  
T +61 2 7900 5580  
F +61 2 8076 3514  
info@boraapac.com.au  
www.boraapac.com.au

**Austria:**

**BORA Vertriebs GmbH & Co KG**  
Prof.-Dr.-Anton-Kathrein-Straße 3  
6342 Niederndorf  
Österreich  
T +43 (0) 5373 / 62250-0  
F +43 (0) 5373 / 62250-90  
mail@bora.com  
www.bora.com

**Europe:**

**BORA Holding GmbH**  
Prof.-Dr.-Anton-Kathrein-Straße 3  
6342 Niederndorf  
Austria  
T +43 (0) 5373 / 62250-0  
F +43 (0) 5373 / 62250-90  
mail@bora.com  
www.bora.com

